

IS32LT3961

CONSTANT-CURRENT 2-AMPERE PWM DIMMABLE BUCK REGULATOR LED DRIVER WITH OUTPUT FAULT REPORTING

December 2021

GENERAL DESCRIPTION

The IS32LT3961 is a DC-to-DC switching converter that integrates an N-channel MOSFET to operate in a buck configuration. The device can operate from a wide input voltage between 5V and 60V and provides a constant current of up to 2A for driving a single LED or multiple series connected LEDs.

The external high-side resistor, R_{IS} , is used to set a constant LED output current, while allowing the output voltage to be automatically adjusted for a variety of LED configurations.

The IS32LT3961 operates in a fixed frequency mode during switching. There is an external resistor connected between the VCC and TON pins used to configure the on-time (switching frequency). The switching frequency is dithered for spread spectrum operation which will spread the electromagnetic energy into a wider frequency band. This function is helpful for optimizing EMI performance.

Either a logic input PWM signal applied to the enable (EN/PWM) pin or an analog signal applied to ADIM pin will adjust the average LED current. The LED brightness is proportional to either the duty cycle of the PWM signal or the voltage level of the analog signal. The analog dimming function can be used to implement either LED binning or LED over temperature thermal roll off protection.

True average output current operation is achieved with fast transient response by using cycle-by-cycle, controlled on-time method.

The IS32LT3961 is available in an eTSSOP-16 package with an exposed pad for enhanced thermal dissipation. It operates from 5V to 60V over the temperature range of -40°C to +150°C.

FEATURES

- Wide input voltage supply from 5V to 60V
- High-side current sensing with LED string cathode connected directly to GND
- True average output current control with $\pm 5\%$ output current accuracy over operating temperature range of -40°C to +150°C
- 2A maximum output over operating temperature range
- Cycle-by-cycle current limit
- Integrated high-side MOSFET switch
- PWM dimming capability
- Analog dimming for LED binning or thermal roll off protection
- Internal control loop compensation
- Under-voltage lockout (UVLO)
- Low power shutdown (1 μ A typical)
- Spread spectrum to optimize EMI
- Support an output current monitor signal
- Robust fault protection and reporting function:
 - Single LED short detect
 - LED string open/short
 - LED over temperature thermal roll off
 - Pin-to-GND short
 - Component open/short faults
 - Adjacent pin-to-pin short
 - Thermal shutdown
- AEC-Q100 Qualified

APPLICATIONS

- Matrix headlight
- Daytime running lights
- Turn/stop lights
- Front and rear fog lights
- Map light
- Motorcycle headlight

IS32LT3961

TYPICAL APPLICATION CIRCUIT

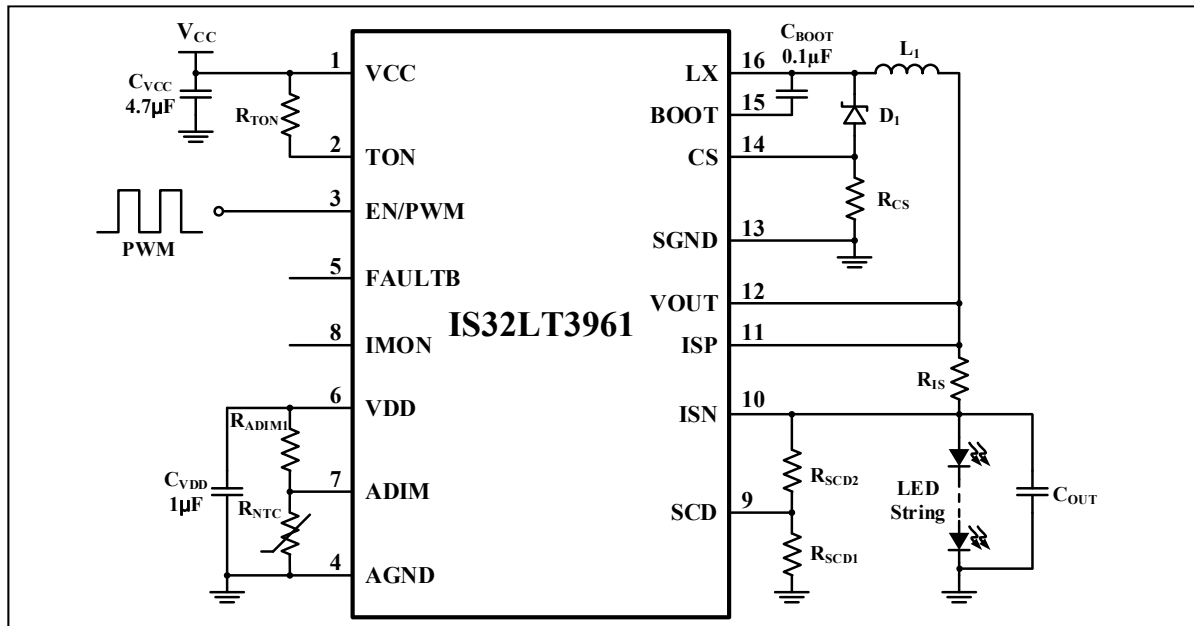
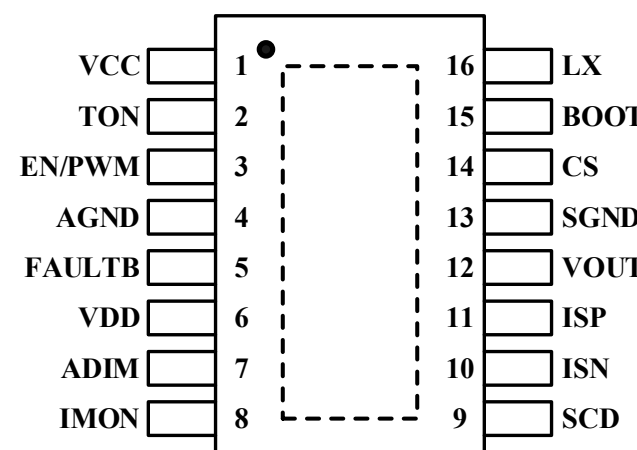

Figure 1 Typical Application Circuit

IS32LT3961

PIN CONFIGURATION

Package	Pin Configuration (Top View)
eTSSOP-16	

PIN DESCRIPTION

No.	Pin	Description
1	VCC	Power supply input. Connect a bypass capacitor C_{VCC} to ground. The path from C_{VCC} to GND and VCC pins should be as short as possible.
2	TON	On-time setting. Connect a resistor from this pin to VCC pin to set the regulator controlled switching on-time.
3	EN/PWM	Logic input for enable and PWM dimming. Pull up above 1.4V to enable and below 0.4V to disable. Input a 100Hz~20kHz PWM signal to dim the LED brightness.
4	AGND	Analog ground.
5	FAULTB	Open drain diagnostic pin. Active low to indicate fault conditions.
6	VDD	Internal 6V (typ.) LDO output. Connect a 1 μ F X7R type ceramic capacitor to GND. This capacitor must be placed as close to VDD pin as possible.
7	ADIM	Analog dimming pin.
8	IMON	Output current monitor output pin.
9	SCD	LED short detection threshold setting pin. Connect a resistor divider from LED+ to ground.
10	ISN	Current sense negative pin.
11	ISP	Current sense positive pin.
12	VOUT	Output voltage sense pin.
13	SGND	Power ground. CS sense resistor MUST be connected to this ground pin.
14	CS	Current ripple sense pin.
15	BOOT	Internal MOSFET gate driver bootstrap. Connect a 0.1 μ F X7R ceramic capacitor from this pin to LX pin.
16	LX	Internal high-side MOSFET switch output. Connect this pin to the inductor and Schottky diode.
	Thermal Pad	Connect to GND.

IS32LT3961

ORDERING INFORMATION

Automotive Range: -40°C to +125°C

Order Part No.	Package	QTY/Reel
IS32LT3961-ZLA3-TR	eTSSOP-16, Lead-free	2500/Reel
IS32LT3961-ZLA3		96/Tube

Copyright © 2021 Lumissil Microsystems. All rights reserved. Lumissil Microsystems reserves the right to make changes to this specification and its products at any time without notice. Lumissil Microsystems assumes no liability arising out of the application or use of any information, products or services described herein. Customers are advised to obtain the latest version of this device specification before relying on any published information and before placing orders for products.

Lumissil Microsystems does not recommend the use of any of its products in life support applications where the failure or malfunction of the product can reasonably be expected to cause failure of the life support system or to significantly affect its safety or effectiveness. Products are not authorized for use in such applications unless Lumissil Microsystems receives written assurance to its satisfaction, that:

- a.) the risk of injury or damage has been minimized;
- b.) the user assume all such risks; and
- c.) potential liability of Lumissil Microsystems is adequately protected under the circumstances

IS32LT3961

ABSOLUTE MAXIMUM RATINGS (Note 1)

Input voltage, V_{CC}	-0.3V ~ +66V
Bootstrap to switching voltage, ($V_{BOOT} - V_{LX}$)	-0.3V ~ +6.6V
Switching voltage, V_{LX} (Steady state)	-0.6V ~ $V_{CC} + 0.3V$
Switching voltage, V_{LX} (Transient < 10ns)	-3.0V
EN/PWM, TON, ISP, ISN, SCD and VOUT voltage, $V_{EN/PWM}$, V_{TON} , V_{ISP} , V_{ISN} , V_{SCD} , and V_{OUT}	-0.3V ~ $V_{CC} + 0.3V$
VDD, IMON, FAULTB, CS and ADIM voltage, V_{DD} , V_{IMON} , V_{FAULTB} , V_{CS} , V_{ADIM}	-0.3V ~ 6.6V
Power dissipation, $P_{D(MAX)}$	2.74W
Operating temperature, $T_A = T_J$	-40°C ~ +150°C
Storage temperature, T_{STG}	-65°C ~ +150°C
Junction temperature, T_{JMAX}	+150°C
Junction Package thermal resistance, junction to ambient (4-layer standard test PCB based on JEDEC 51-2A), θ_{JA}	45.6°C/W
Package thermal resistance, junction to thermal PAD (4-layer standard test PCB based on JEDEC 51-8), θ_{JP}	1.617°C/W
ESD (HBM)	±2kV
ESD (CDM)	±750V

Note 1: Stresses beyond those listed under “Absolute Maximum Ratings” may cause permanent damage to the device. These are stress ratings only and functional operation of the device at these or any other condition beyond those indicated in the operational sections of the specifications is not implied. Exposure to absolute maximum rating conditions for extended periods may affect device reliability.

ELECTRICAL CHARACTERISTICS

$V_{CC} = 24V$, $T_J = T_A = -40^\circ C \sim +150^\circ C$, Typical values are at $T_J = 25^\circ C$, unless otherwise noted.

Symbol	Parameter	Conditions	Min.	Typ.	Max.	Unit
V_{CC}	Input supply voltage		5		60	V
V_{UVLO}	VCC undervoltage lockout threshold	V_{CC} rising	4.45	4.7	4.95	V
V_{UVLO_HY}	VCC undervoltage lockout hysteresis	V_{CC} falling		200		mV
I_{CC}	Quiescent current	($V_{ISP} - V_{ISN}$) = 0.25V, $V_{EN/PWM}$ = high		1.5	2.5	mA
I_{SD}	Shutdown current	EN/PWM shorted to GND		1	10	μA
V_{DD}	Regulator output voltage		5.8	6	6.2	V
$I_{VDD(ILIM)}$	VDD LDO current limit	VDD short to GND	22	37		mA
I_{SWLIM}	Buck switch current limit threshold		2.5	3.5	4.5	A
t_{OCP}	Over Current Protection (OCP) hiccup time	(Note 2)		10		ms
R_{DS_ON}	Buck switch on-resistance	$V_{BOOT} = V_{CC} + 5V$, $I_{LX} = 1A$		0.2	0.4	Ω
V_{BTUV}	BOOT undervoltage lockout threshold	V_{BOOT} to V_{LX} rising		2.85		V
V_{BTUV_HY}	BOOT undervoltage lockout hysteresis	V_{BOOT} to V_{LX} falling		350		mV
t_{OFF_MIN}	Switching minimum off-time	$V_{FB} = 0V$		90	130	ns
t_{ON_MIN}	Switching minimum on-time			90	130	ns
t_{ON}	Selected on-time	$V_{CC} = 24V$, $V_{OUT} = 12V$, $R_{TON} = 580k\Omega$	800	1000	1200	ns
Regulation Comparator and Error Amplifier						
V_{IS}	100% Load current sense regulation threshold ($V_{ISP} - V_{ISN}$)	($V_{ISP} - V_{ISN}$) falling, LX turns on, $V_{ISN} = 12V$, $V_{ADIM} = 2.5V$	194	200	206	mV
		($V_{ISP} - V_{ISN}$) falling, LX turns on, $V_{ISN} = 0V$, $V_{ADIM} = 2.5V$	190	200	210	

IS32LT3961

ELECTRICAL CHARACTERISTICS (CONTINUE)

$V_{CC}=24V$, $T_A=T_J = -40^{\circ}C \sim +150^{\circ}C$, Typical values are at $T_J = 25^{\circ}C$, unless otherwise noted.

Symbol	Parameter	Conditions	Min.	Typ.	Max.	Unit
V_{IS20}	Load current sense regulation threshold ($V_{ISP}-V_{ISN}$) with 20% analog dimming	($V_{ISP}-V_{ISN}$) falling, LX turns on, $V_{ISN}=12V$, $V_{ADIM}=0.72V$	37.5	40	42.5	mV
		($V_{ISP}-V_{ISN}$) falling, LX turns on, $V_{ISN}=0V$, $V_{ADIM}=0.72V$	37.5	40	42.5	
V_{IS10}	Load current sense regulation threshold ($V_{ISP}-V_{ISN}$) with 10% analog dimming	($V_{ISP}-V_{ISN}$) falling, LX turns on, $V_{ISN}=12V$, $V_{ADIM}=0.56V$	17.5	20	22.5	mV
		($V_{ISP}-V_{ISN}$) falling, LX turns on, $V_{ISN}=0V$, $V_{ADIM}=0.56V$	17.5	20	22.5	
V_{ISN_RTH}	ISP/ISN low side to high side switchover voltage	$V_{ISP}=V_{ISN}$		2.7		V
V_{ISN_FTH}	ISP/ISN high side to low side switchover voltage	$V_{ISP}=V_{ISN}$		2.2		V
I_{ISP}	ISP pin bias current	$V_{ISP}=12.2V$, $V_{ISN}=12V$		176		μA
		$V_{ISP}=0.2V$, $V_{ISN}=0V$		-50		
I_{ISN}	ISN pin bias current	$V_{ISP}=12.2V$, $V_{ISN}=12V$		100		μA
		$V_{ISP}=0.2V$, $V_{ISN}=0V$		-100		
V_{IMON}	Output current monitor	($V_{ISP}-V_{ISN}$) =200mV		2		V
V_{ADIM}	Analog dimming range		0.4		2	V
V_{ADIM_100}	Analog dimming fully on threshold		2.1			V
V_{ADIM_BF}	Analog dimming blocks output LED short fault detection threshold	Voltage falling		0.45		V
V_{ADIM_BFHY}	Analog dimming blocks output LED short fault detection hysteresis			50		mV
V_{ADIM_OFF}	ADIM force output off threshold	Voltage falling		0.28		V
V_{ADIM_OFFHY}	ADIM force output off hysteresis			40		mV
I_{ADIM}	ADIM pin input current	$V_{ADIM} > 2V$ (Note 2)		-25		nA
		$V_{ADIM} < 2V$ (Note 2)		0		
V_{CS_TH1}	Buck valley current limit		42	50	58	mV
V_{CS_TH2}	Inductor peak current limit			100		mV
FAULT OUTPUT						
V_{FAULTB}	FAULTB pin pull down voltage	Fault condition, sink current $I_{OL} = 5mA$		0.1	0.2	V
I_{LK_FAULTB}	FAULTB pin leakage current	No fault condition, pull up to 6V			1	μA
t_{DELAY1}	Fault detect to fault report delay time			10		ms
t_{DELAY2}	Fault recover to fault report delay time			10		ms
Enable Input						
V_{IH}	Logic high voltage	Voltage rising	2			V
V_{IL}	Logic low voltage	Voltage falling			0.8	V

IS32LT3961

ELECTRICAL CHARACTERISTICS (CONTINUE)

$V_{CC} = 24V$, $T_A = T_J = -40^{\circ}C \sim +150^{\circ}C$, Typical values are at $T_J = 25^{\circ}C$, unless otherwise noted.

Symbol	Parameter	Conditions	Min.	Typ.	Max.	Unit
R_{PWMPD}	EN/PWM pin pull-down resistance	$V_{EN/PWM} = 5V$		200		k Ω
t_{PWML}	Duration EN/PWM pin kept low to shut down the device		105	130	155	ms
t_{PWMLH}	Duration EN/PWM pin kept high to quit from shutdown mode			10	25	μs
t_{PWMSW}	The latency of EN/PWM pull high to IC starts switching			200	300	μs
V_{SCD_TH}	Output LED shorted detection threshold	Voltage falling	1.12	1.15	1.18	V
V_{SCD_HYS}	Output LED shorted detection threshold hysteresis			50		mv
Thermal Shutdown						
T_{SD}	Thermal shutdown threshold	(Note 2)		170		$^{\circ}C$
T_{SDHYS}	Thermal shutdown hysteresis	(Note 2)		20		$^{\circ}C$

Note 2: Guaranteed by design.

IS32LT3961

FUNCTIONAL BLOCK DIAGRAM

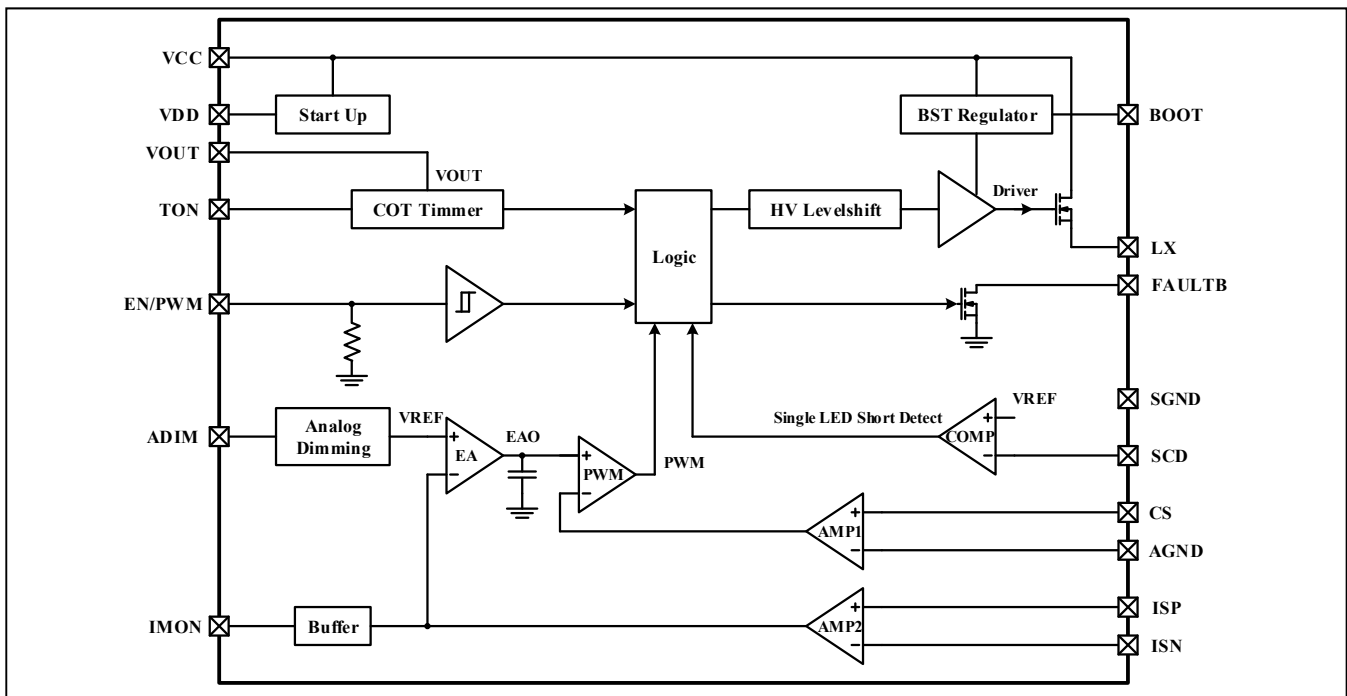

IS32LT3961

TYPICAL PERFORMANCE CHARACTERISTICS

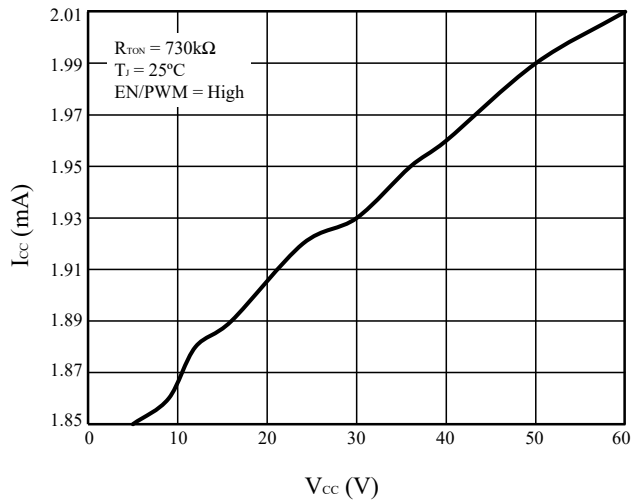

Figure 2 I_{CC} vs. V_{CC}

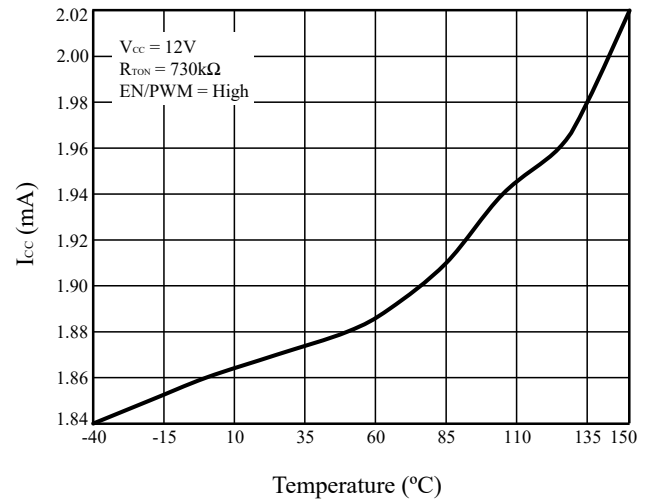

Figure 3 I_{CC} vs. Temperature

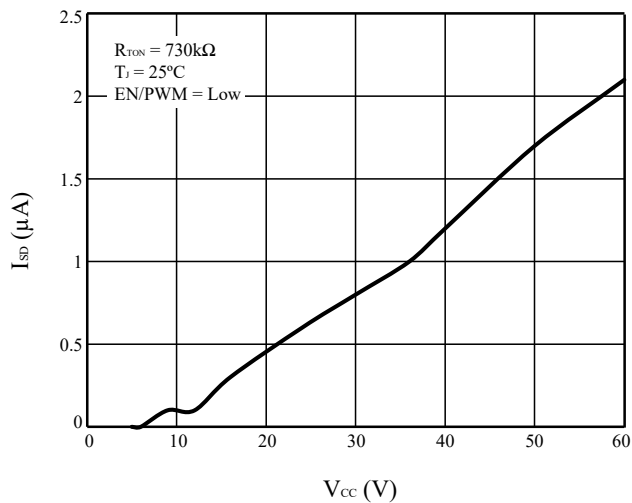

Figure 4 I_{SD} vs. V_{CC}

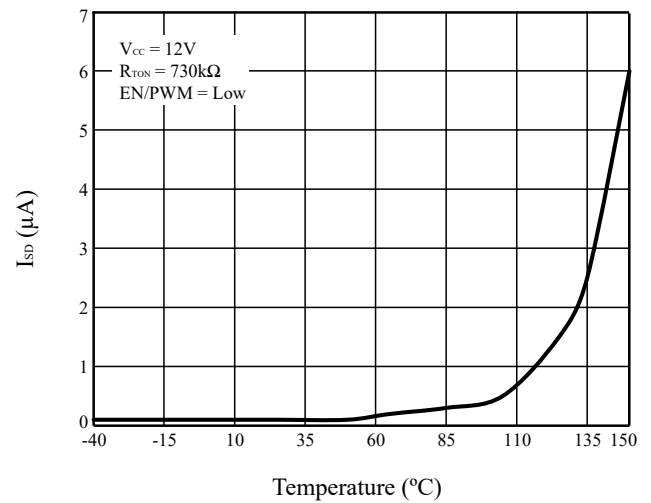

Figure 5 I_{SD} vs. Temperature

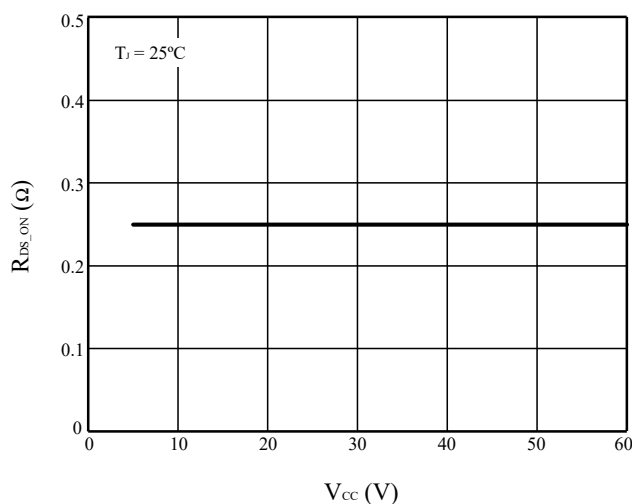

Figure 6 R_{DS_ON} vs. V_{CC}

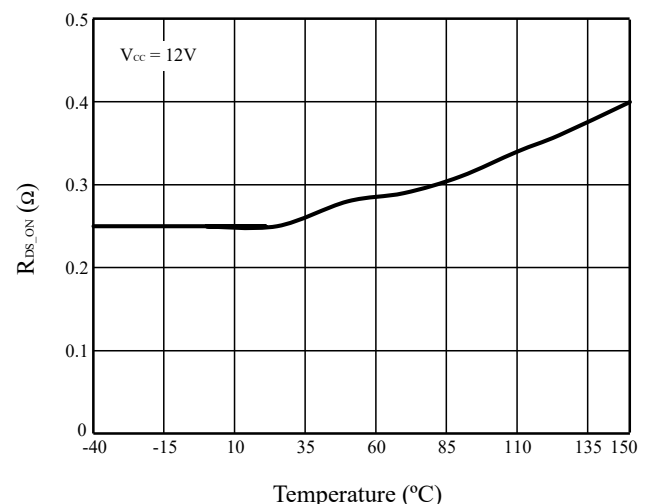

Figure 7 R_{DS_ON} vs. Temperature

IS32LT3961

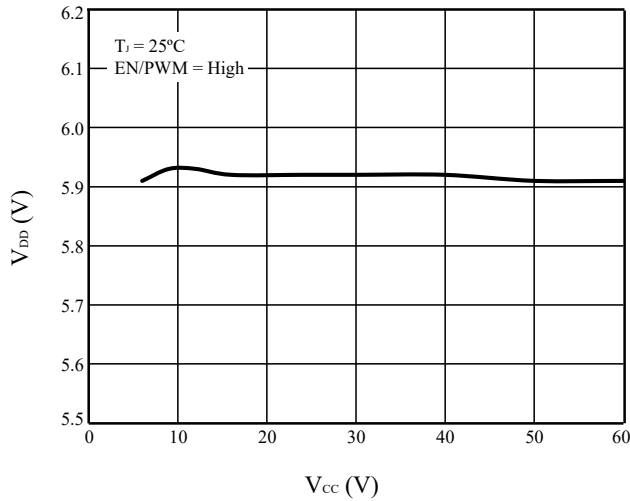

Figure 8 V_{DD} vs. V_{CC}

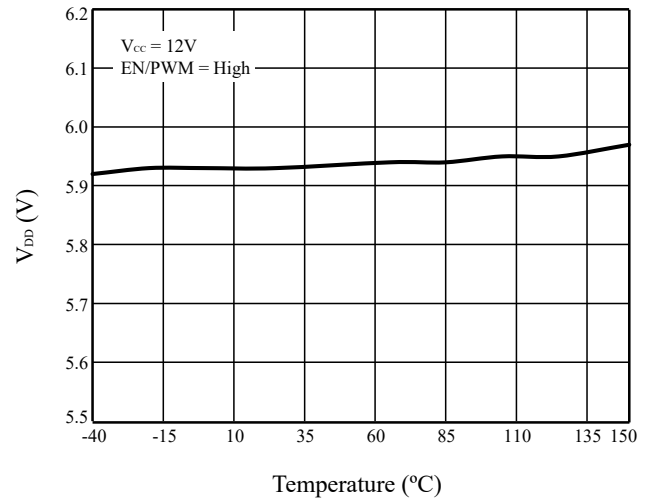

Figure 9 V_{DD} vs. Temperature

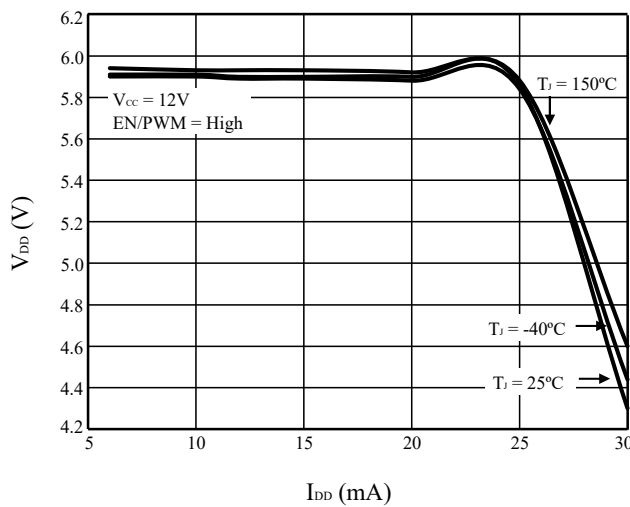

Figure 10 V_{DD} vs. I_{DD}

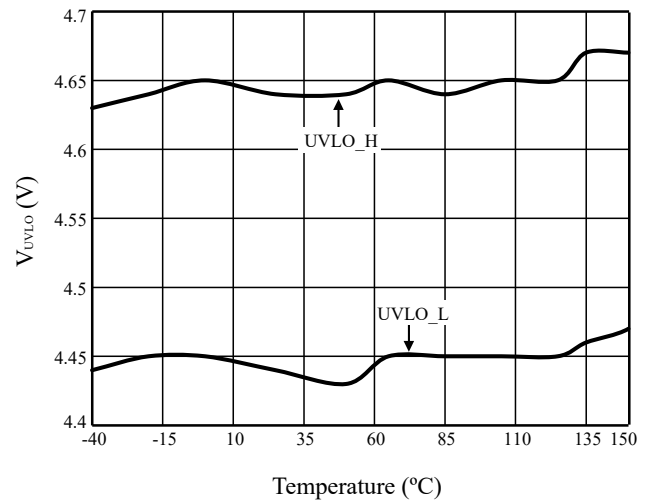

Figure 11 V_{UVLO} vs. Temperature

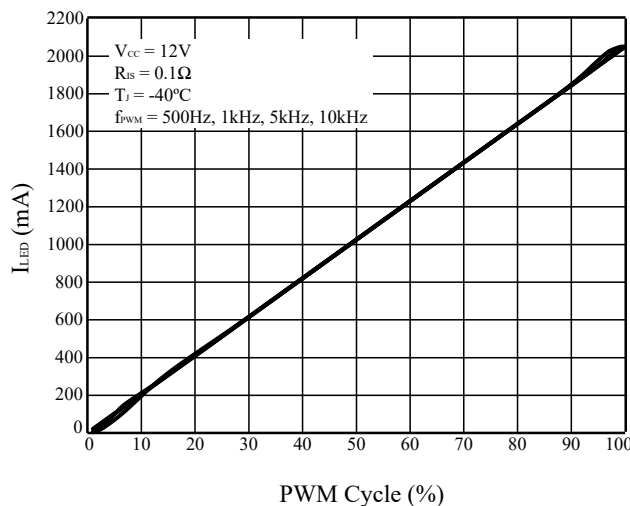

Figure 12 I_{LED} vs. PWM Cycle

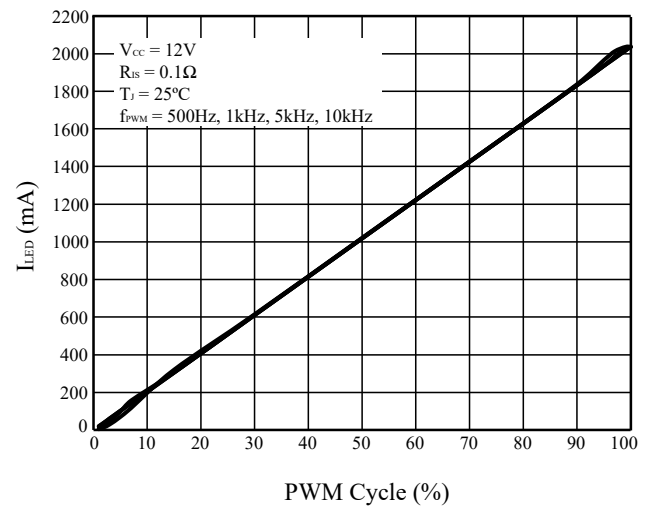

Figure 13 I_{LED} vs. PWM Cycle

IS32LT3961

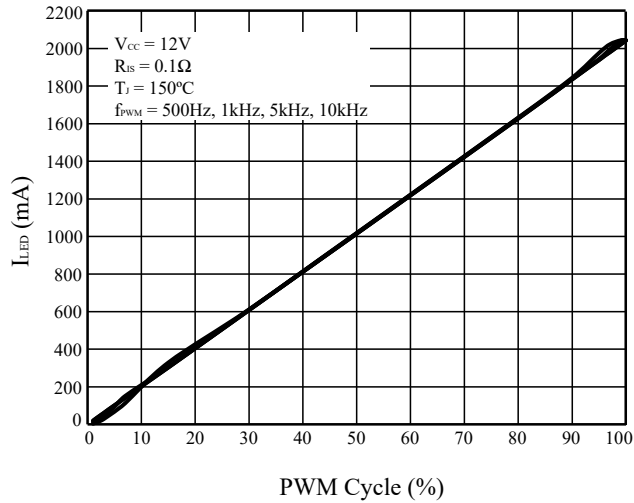

Figure 14 I_{LED} vs. PWM Cycle

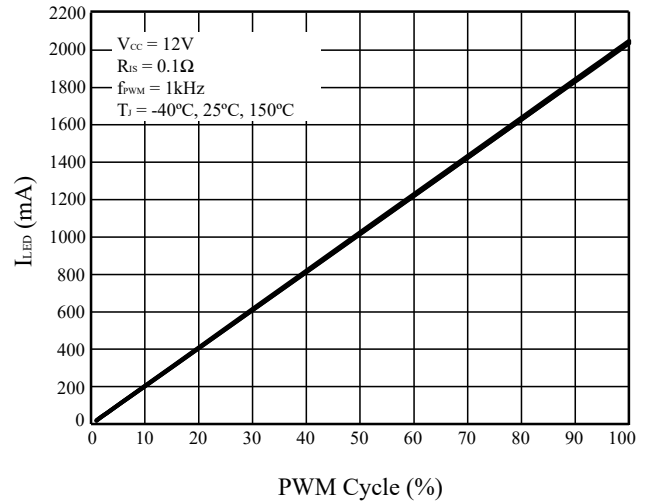

Figure 15 I_{LED} vs. PWM Cycle

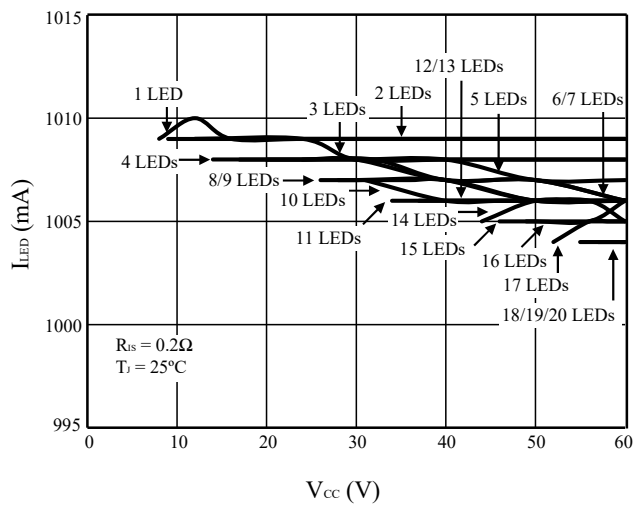

Figure 16 I_{LED} vs. V_{CC}

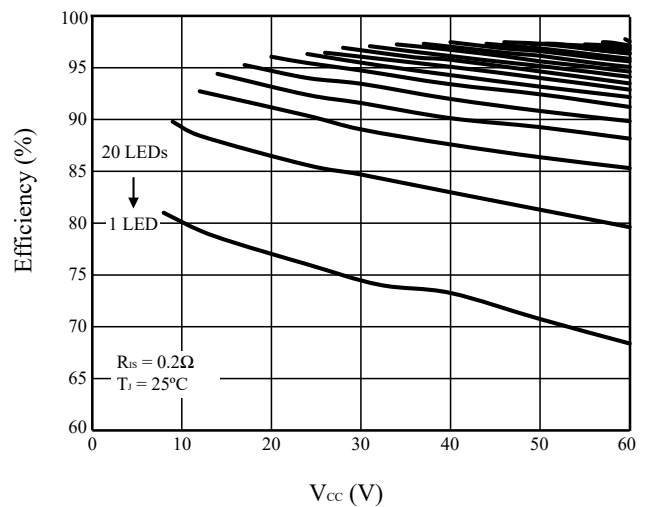

Figure 17 Efficiency vs. V_{CC}

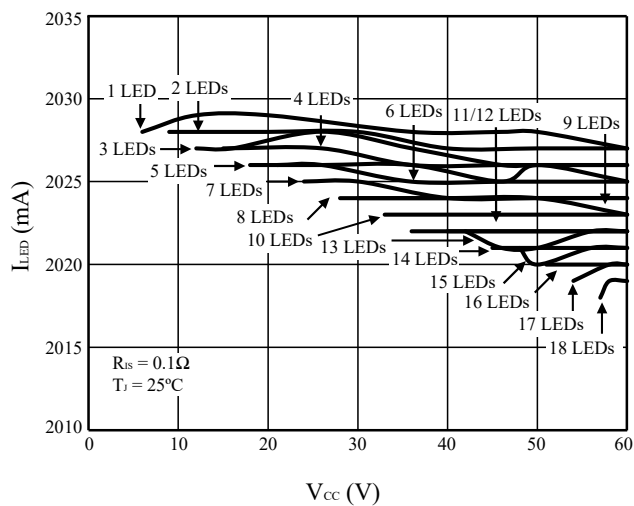

Figure 18 I_{LED} vs. V_{CC}

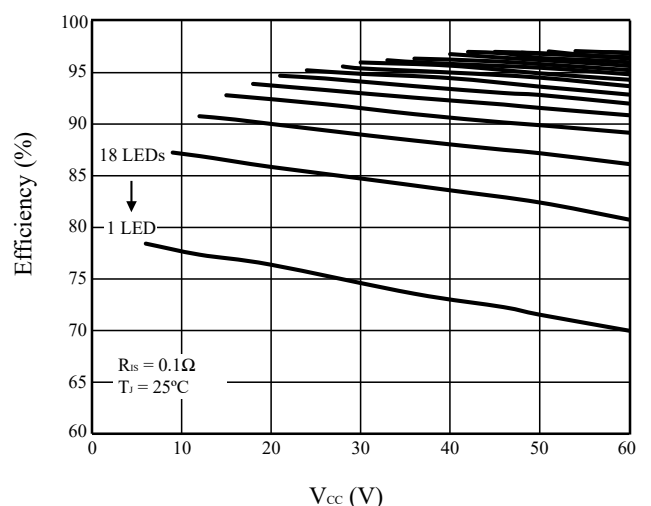

Figure 19 Efficiency vs. V_{CC}

IS32LT3961

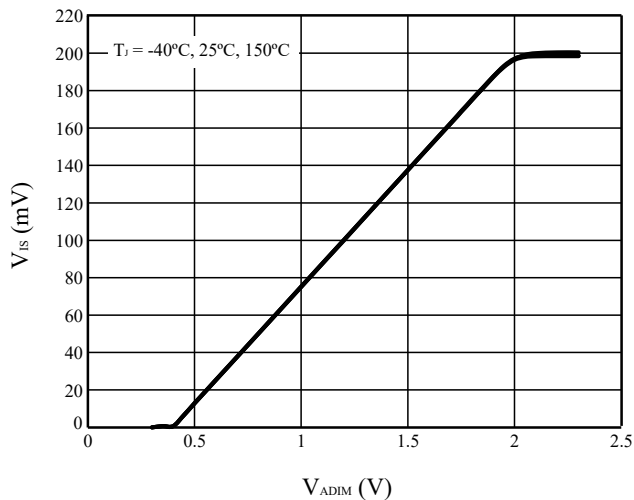

Figure 20 V_{IS} vs. V_{ADIM}

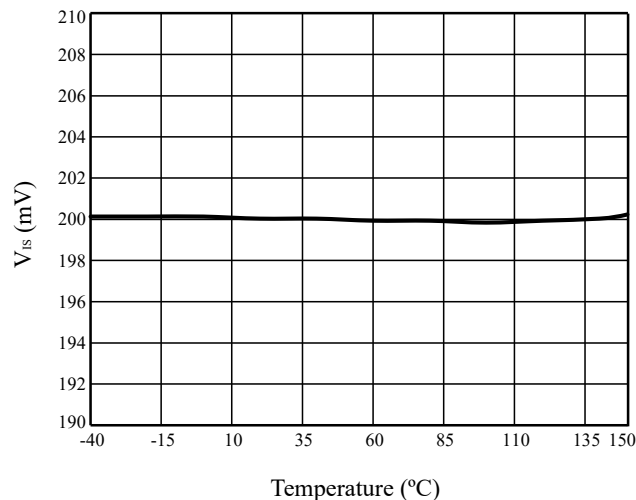

Figure 21 V_{IS} vs. Temperature

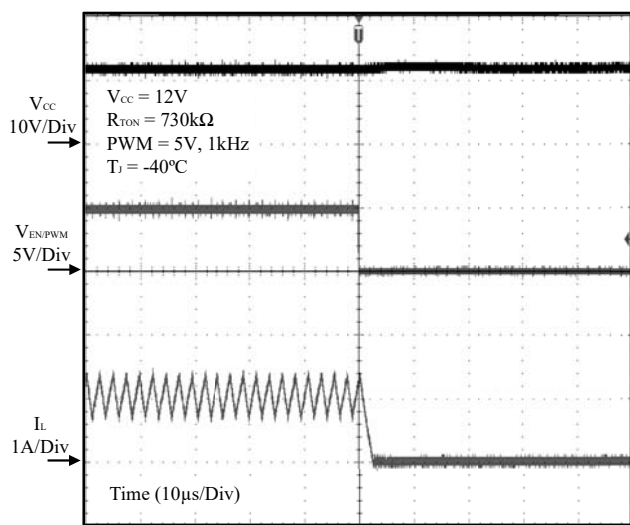

Figure 22 PWM Off

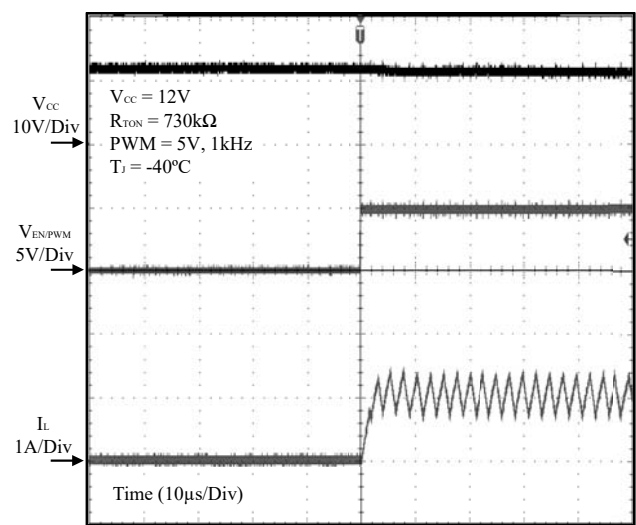

Figure 23 PWM On

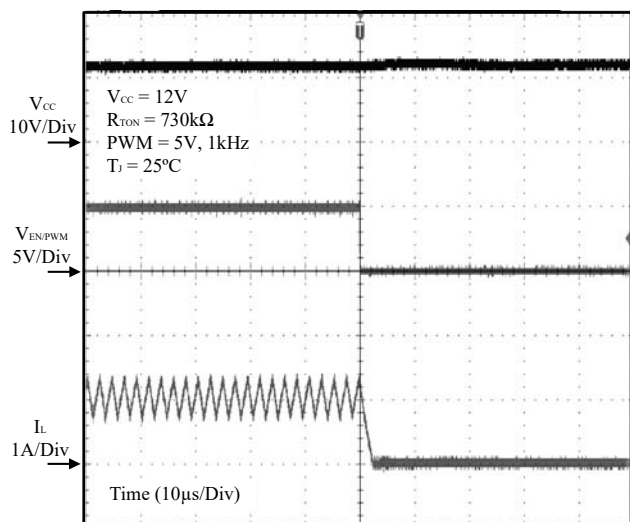

Figure 24 PWM Off

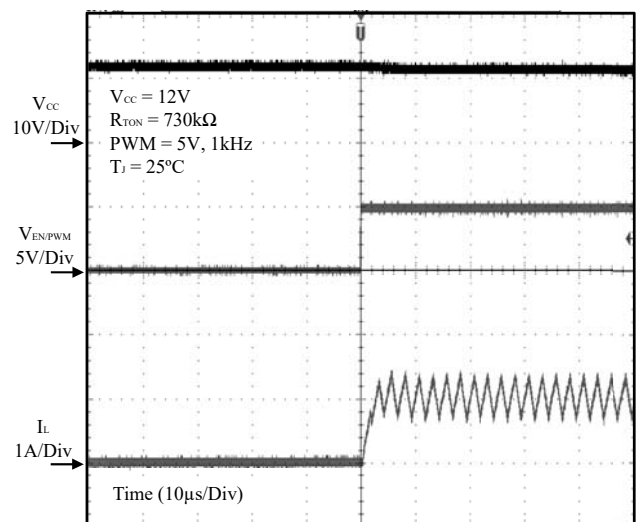

Figure 25 PWM On

IS32LT3961

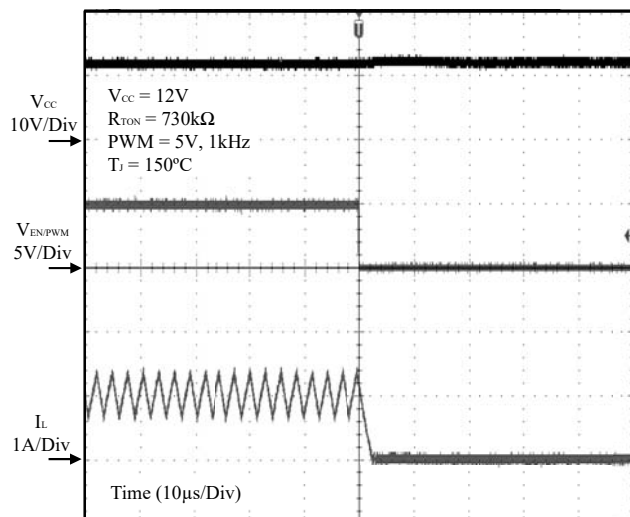

Figure 26 PWM Off

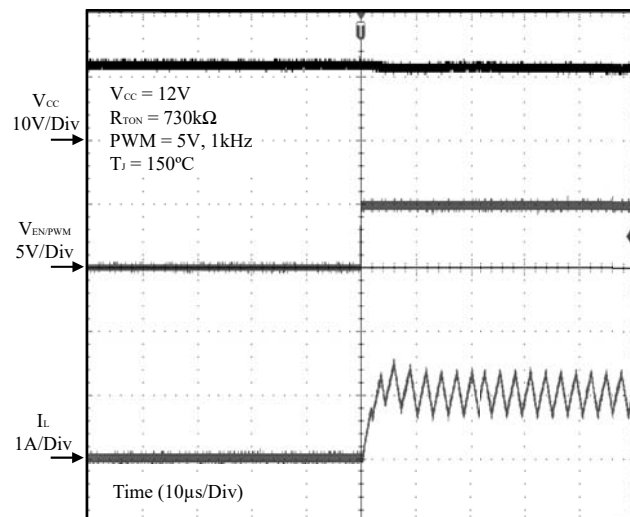

Figure 27 PWM On

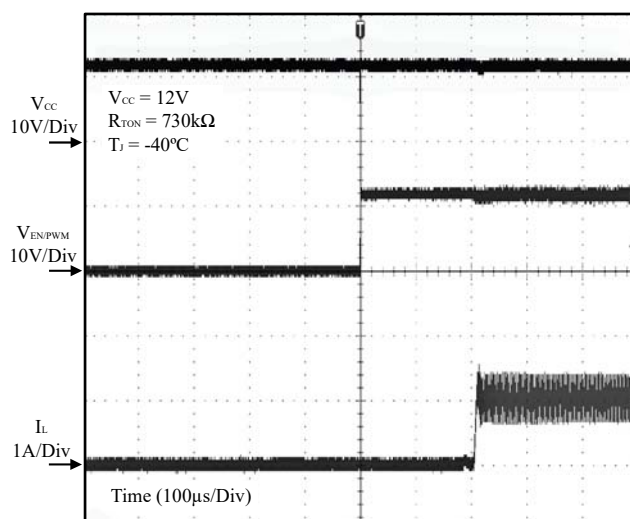

Figure 28 EN/PWM Enable

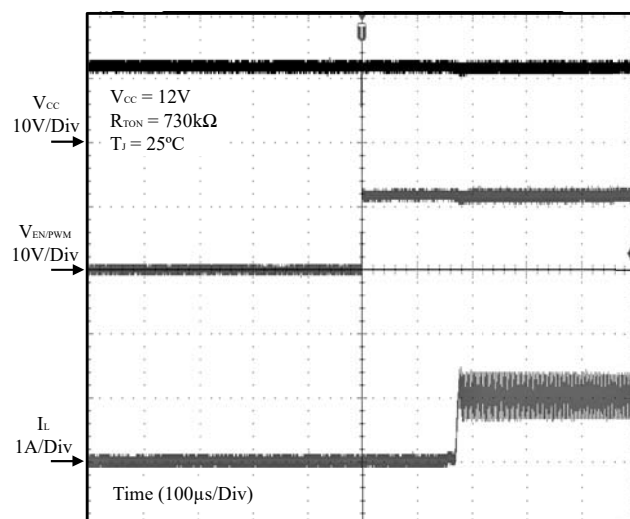

Figure 29 EN/PWM Enable

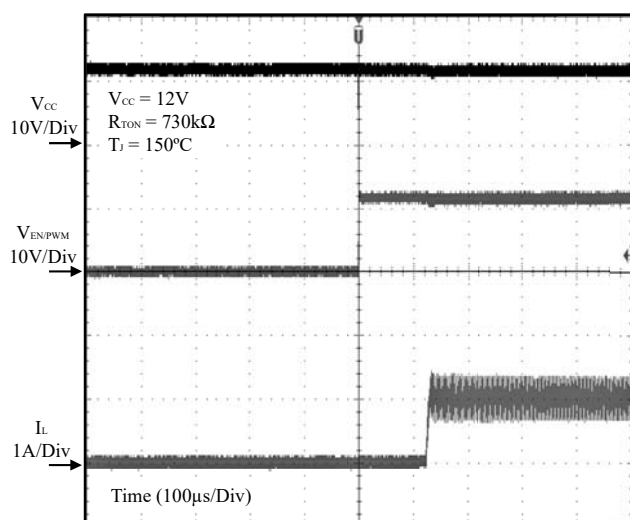

Figure 30 EN/PWM Enable

IS32LT3961

APPLICATION INFORMATION

DESCRIPTION

The IS32LT3961 is a buck regulator with wide input voltage, low reference voltage, quick output response and excellent PWM/analog dimming performance, which is ideal for driving a high-current LED string. It uses average current mode control to maintain constant LED current for consistent brightness.

UNDER VOLTAGE LOCKOUT (UVLO)

The IS32LT3961 features an under voltage lockout (UVLO) function on the VCC pin. This is a fixed value which cannot be adjusted. The device is enabled when the VCC voltage rises to exceed V_{UVLO} (Typ. 4.7V), and disabled when the VCC voltage falls below ($V_{UVLO} - V_{UVLO_HY}$) (Typ. 4.5V).

VDD

The IS32LT3961 integrates a 6.0V linear regulator with $I_{VDD(ILIM)}$ current limit to power the internal control circuits. Its output is the VDD pin which requires a 1 μ F low ESR, X7R type ceramic capacitor from VDD to GND for proper operation. In general, this output must not be loaded with any external circuitry. However, it can be used to supply the reference voltage for the ADIM input or for the pullup resistor used with the FAULTB output.

BOOTSTRAP CIRCUIT

The gate driver of the integrated high-side MOSFET requires a voltage above VCC as an input power supply. As below circuit diagram, there is another dedicated internal 5.5V LDO which is the power supply of the gate driver. The BOOT pin is internally connected to the output of the 5.5V LDO. Connect a ceramic capacitor between BOOT and LX pins. The VCC supplies the power to the 5.5V LDO which charges the C_{BOOT} capacitor during high-side MOSFET off cycles. Then in high-side MOSFET on cycles, the C_{BOOT} charge voltage is used to boost the BOOT pin to 5.5V higher than LX pin.

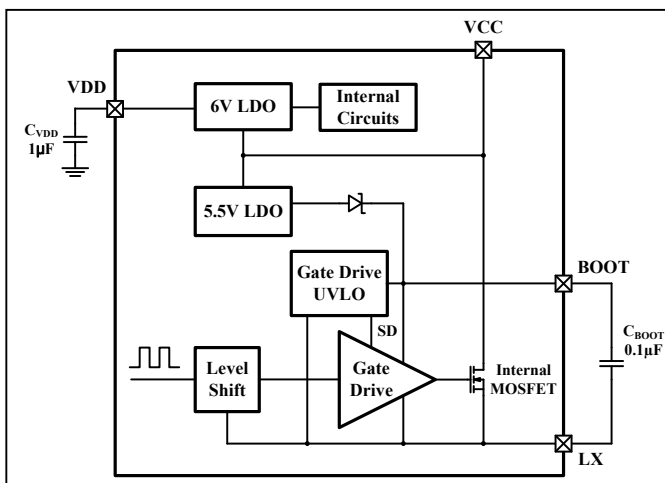

Figure 31 LDOs and Bootstrap Circuit

A 0.1 μ F X7R ceramic capacitor will work well in most applications. The gate driver also has an under voltage lockout detection. The gate driver is enabled when the voltage on the C_{BOOT} rises to above V_{BTUV} (Typ. 2.85V), and disabled when the voltage on the C_{BOOT} drops below ($V_{BTUV} - V_{BTUV_HY}$) (Typ. 2.5V).

OUTPUT CURRENT SETTING

The LED current is configured by an external sense resistor, R_{IS} , with a value determined by the following Equation (1):

$$I_{LED} = \frac{V_{IS}}{R_{IS}} \quad (1)$$

Where the analog dimming function is disabled ($V_{ADIM} > 2V$) and $V_{IS} = 0.2V$ (Typ.).

Note that $R_{IS} = 0.1\Omega$ is the minimum allowed value for the sense resistor in order to maintain the switch current below the specified maximum value.

Table 1 R_{IS} Resistance Versus Output Current

R_{IS} (Ω)	Nominal Average Output Current (mA)
0.3	667
0.2	1000
0.1	2000

The resistor R_{IS} should be a 1% resistor with enough power tolerance and good temperature characteristic to ensure accurate and stable output current.

LOW-SIDE CURRENT SENSE AND INDUCTOR PEAK CURRENT LIMIT

During the high-side MOSFET off phase, the CS pin is used to sense the inductor current ripple via a low-side current sense resistor, R_{CS} , for loop control and the inductor valley current limit, $I_{L_V LIM}$. Once the inductor valley current exceeds $I_{L_V LIM}$, the device will operate in minimum off-time to increase the inductor current until trigger either inductor peak current limit or high-side MOSFET over current protection (OCP). In most applications, the recommended inductor valley current limit ($I_{L_V LIM}$) is 1.2 times of maximum LED current. So, the R_{CS} value should be determined by the desired LED current, as in the following Equation (2):

$$R_{CS} = \frac{V_{CS_TH1}}{1.2 \times I_{LED}} \quad (2)$$

Where $V_{CS_TH1} = 0.05V$ (Typ.).

The resistor R_{CS} should be a 1% resistor with enough power tolerance and good temperature characteristic to ensure accurate and stable output current.

The CS pin also limits the inductor peak current. The inductor peak current limit level is:

IS32LT3961

$$I_{L_LIM} = \frac{V_{CS_TH2}}{R_{CS}} \quad (3)$$

Where $V_{CS_TH2} = 0.1V$ (Typ.).

During the high-side MOSFET off phase, if the current through R_{CS} exceeds the inductor peak current limit level, I_{L_LIM} , the device will immediately turn off the high-side MOSFET for t_{OCP} and restart again. The FAULTB pin pulls low to report the fault condition. The device will remain in this hiccup mode until the current drops below I_{L_LIM} . And the FAULTB pin will resume to high impedance.

In order to improve EMI performance, a RC snubber network might be added across the Schottky diode D_1 . In this case, the RC snubber network should be connected in parallel with the Schottky diode but excluding the low-side current sense resistor R_{CS} that prevents the current sensing of R_{CS} resistor from being affected by the RC snubber.

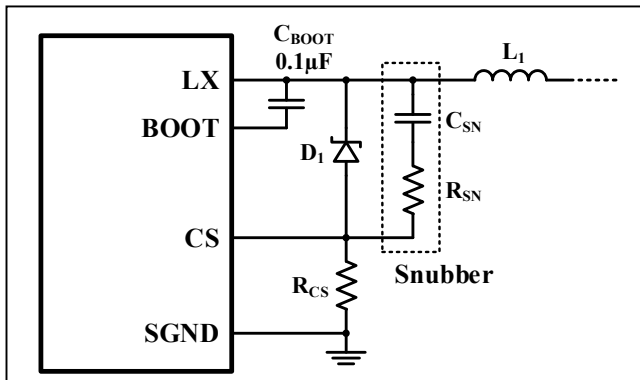

Figure 32 Adding RC Snubber

ENABLE AND PWM DIMMING

A high logic signal on the EN/PWM pin will enable the IC. The buck converter ramps up the LED current to a target level which is set by external resistor, R_{IS} .

When the EN/PWM pin goes from high to low, the buck converter will turn off, but the IC remains in standby mode for up to t_{PWML} . When the EN/PWM pin goes high within this period, the LED current will turn on immediately. Sending a PWM (pulse-width modulation) signal to the EN/PWM pin will result in dimming of the LED. The resulting LED brightness is proportional to the duty cycle (t_{ON}/T) of the PWM signal. A practical range for PWM dimming frequency is between 100Hz and 20kHz.

There is an inherent PWM turn on delay time of about 500ns during continuous PWM dimming. A high frequency PWM signal has a shorter period time that will degrade the PWM dimming linearity. Therefore, a low frequency PWM signal is good for achieving better dimming contrast ratio. At a 200Hz PWM frequency, the dimming duty cycle can be varied from 100% down to 1% or lower.

If the EN/PWM pin is kept low for at least t_{PWML} , the IC

enters shutdown mode to reduce power consumption. The next high signal on EN/PWM will initialize a full startup sequence, which includes a shutdown quit time, t_{PWMLH} , and a startup latency, t_{PWMSW} . This startup sequence does not exist in a typical PWM operation.

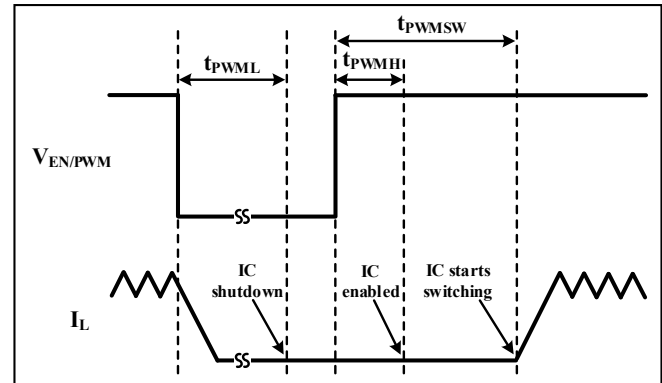

Figure 33 Device Shutdown and Enable

The EN/PWM pin is high-voltage tolerant and can be connected directly to the VCC pin if the EN/PWM pin is unused. However, a series resistor (recommended value is 10kΩ) is required to limit the current flowing into the EN pin if PWM is higher than the V_{CC} voltage at any time. If PWM is driven from a logic input, this series resistor is not necessary.

ANALOG DIMMING

The IS32LT3961 also offers an analog dimming function on input pin, ADIM, whose dimming voltage range is 0.4V to 2V. The current sense voltage threshold, V_{IS} , can be regulated by the ADIM pin voltage. If the ADIM pin is pulled up above 2V, analog dimming is disabled and the output current is given by Equation (1). When the ADIM voltage is driven below 2V, V_{ADIM} will proportionally control the current sense voltage threshold V_{IS} resulting in a change in the output current as given by Equation (4):

$$I_{LED_ADIM} = \frac{V_{ADIM} - 0.4V}{1.6V} \times \frac{V_{IS}}{R_{IS}} \quad (4)$$

Note that the relative current accuracy decreases with the decreasing current sense voltage threshold due to the offset of the internal circuit. Therefore, the recommended minimum analog dimming level is around 10%. At low analog dimming level (such as below 20%), the inductor current ripple will be too large compared to the average current. To improve the dimming linearity, please choose a proper inductor value to get smaller inductor current ripple. Basically, a current ripple of 10%~50% full output current is a good choice for the analog dimming.

IS32LT3961

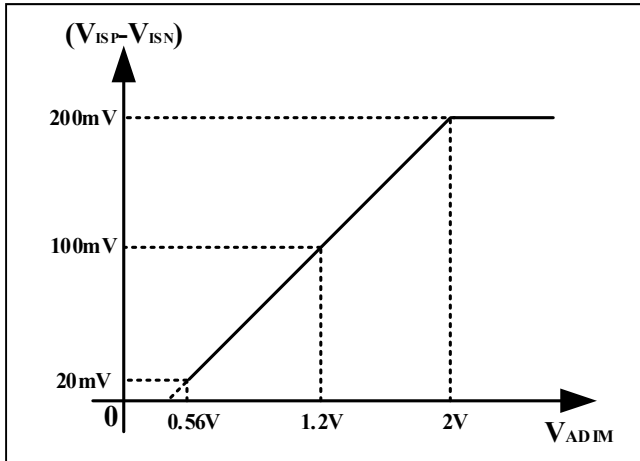

Figure 34 Analog Dimming Graph

Never leave the ADIM pin floating. If the analog dimming function is not implemented, connect the ADIM pin either to a voltage level within 2V to 6V, or the VDD pin via a resistor (recommended value is 10kΩ).

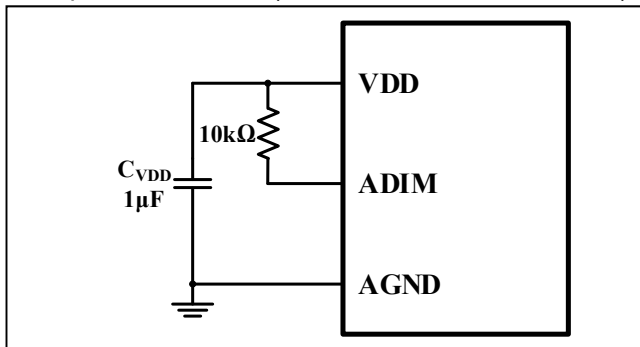

Figure 35 ADIM Pin Unused

According to above equation, the ADIM should be able to dim the output current to zero, as the ADIM voltage is 0.4V. However, due to the offset of the internal circuit and minimum on-time limit, the output may still have a tiny current. The ADIM pin features a forcing output off threshold, V_{ADIM_OFF} . Pulling the ADIM pin below V_{ADIM_OFF} can completely turn off the output.

It is recommended to add a 10nF ceramic capacitor from the ADIM pin to GND to bypass any high frequency noise, especially if the analog voltage level comes from a long copper trace. This 10nF capacitor should be placed as close to the ADIM pin as possible. The following are some application scenarios for use of the analog dimming function.

LED Binning:

The ADIM pin can be used to fine tune the output current during mass-production. LEDs are typically sorted into various bins of different luminous intensity and forward voltage. To correct the brightness deviation during mass-production, the mean output current can be adjusted by adjusting the voltage level on the ADIM pin. As shown in Figure 36, fix the R_{ADIM1} value and solder different value R_{BIN} resistor to adjust and maintain the same lumen output across different LED bins. This R_{BIN} resistor can be placed on the LED board.

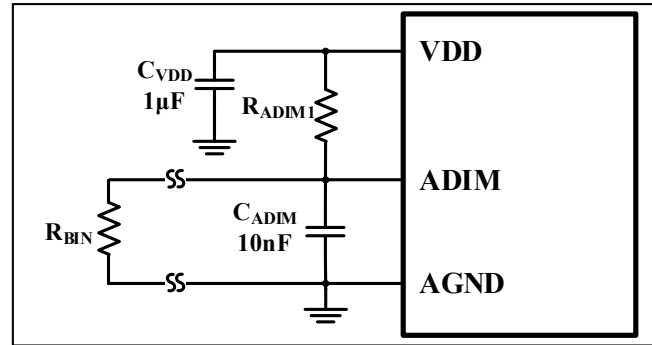

Figure 36 Analog Dimming For LED Binning

Over Temperature Thermal Roll Off:

The ADIM pin can also be used in conjunction with a NTC thermistor to provide over temperature current roll off protection for the LED load or the system. As Figure 37.

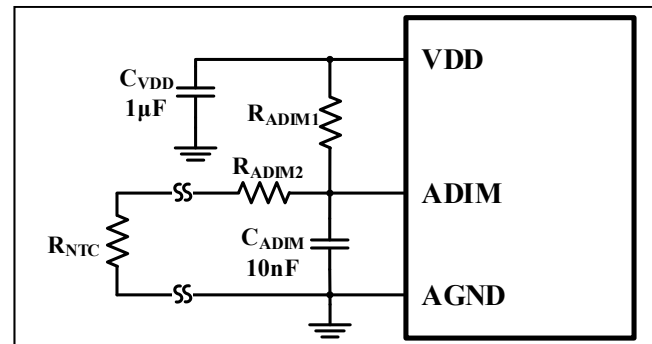

Figure 37 ADIM Pin with NTC for Thermal Roll Off Protection

For example, assume the desired current roll off temperature threshold is T_R and the NTC thermistor resistance is R_{NTCR} at this temperature (R_{NTCR} can be found in the NTC thermistor datasheet), then R_{ADIM1} and R_{ADIM2} can be calculated by:

$$R_{ADIM1} = \frac{(R_{NTCR} + R_{ADIM2}) \times (V_{DD} - 2V)}{2V} \quad (5)$$

For a given NTC thermistor, the R_{ADIM1} resistor will adjust the current roll off temperature threshold. The larger R_{ADIM1} the lower the current roll off temperature threshold. The R_{ADIM2} resistor is optional to be used to adjust current derating slope. The larger R_{ADIM2} the flatter the current derating slope. If R_{ADIM2} is not used, tie the NTC thermistor directly to ADIM pin.

IS32LT3961

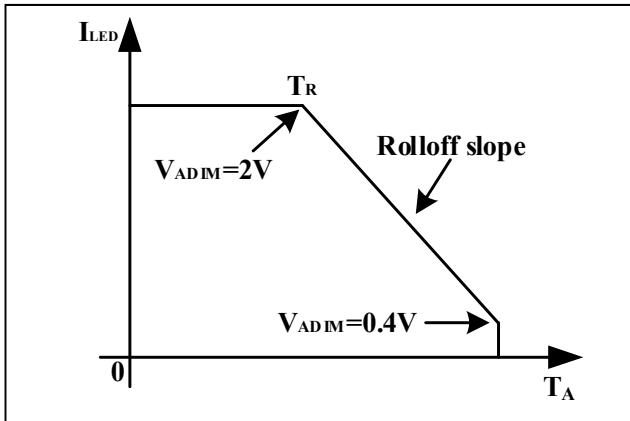

Figure 38 Thermal Roll Off Protection

The NTC thermistor should be placed next to the component to be monitored. Such as the LED board, beside the power MOSFET, and so on.

Dual Brightness Level Output:

In automotive applications, some lamps require a dual brightness output. For instance, the daytime running light (DRL) and the position light (POL) can both use the same LED string, since these two lamps won't be active at the same time. The DRL is active in the daytime, while POL is active with lower brightness in the nighttime. Two brightness levels are selected by two independent power supply rails. The analog dimming can be used for this dual brightness output function.

As Figure 39. When the input logic to the GATE of the MOSFET Q₁ is high, R_{ADIM3} resistor is shorted by Q₁. The output current is determined by the resistor divider R_{ADIM1} and R_{ADIM2}. If the GATE of the switch Q₁ is pulled low, the output current is determined by the resistor divider R_{ADIM1}, R_{ADIM2} and R_{ADIM3} the result is a higher brightness.

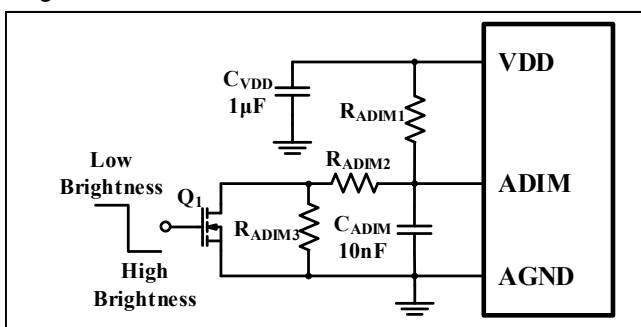

Figure 39 ADIM Pin for Dual Brightness Output

INPUT CAPACITOR

The input capacitor provides the transient pulse current, which is approximately equal to I_{LED}, to the inductor of the converter when the high-side MOSFET is on. An X7R type ceramic capacitor is a good choice for the input bypass capacitor to handle the ripple current since it has a very low equivalent series resistance (ESR) and low equivalent series inductance (ESL). Use the following equation to estimate the approximate

capacitance:

$$C_{VCC_MIN} = \frac{I_{LED} \times t_{ON}}{\Delta V_{CC}} \quad (6)$$

Where, ΔV_{CC} is the acceptable input voltage ripple, generally choose 5%-10% of input voltage. t_{ON} is on-time of the high-side MOSFET in μs . A minimum input capacitance of 2X C_{VCC_MIN} is recommended for most applications.

OUTPUT CAPACITOR

The IS32LT3961 can accept a voltage ripple on the ISP/ISN pins. A capacitor should be added across the LEDs but excluding the R_{IS} resistor. As Figure 40. This capacitor will reduce the LED current ripple while keep the same average current. Meanwhile, this capacitor also helps to reduce the common mode noise on ISP/ISN pins that improves the line regulation accuracy of the output current. The reduction of the LED current ripple by the capacitor depends on several factors: capacitor value, inductor current ripple, operating frequency, output voltage, etc. A 0.1 μF ~2.2 μF capacitor is sufficient for most applications. However, the output capacitor brings in more delay time of LED current during PWM dimming that will degrade the dimming contrast. A too large output capacitor is not recommended.

The output capacitor is used to filter the LED current ripple to an acceptable level. The equivalent series resistance (ESR), equivalent series inductance (ESL) and capacitance of the capacitor contribute to the output current ripple. Therefore, a low-ESR X7R type capacitor should be used.

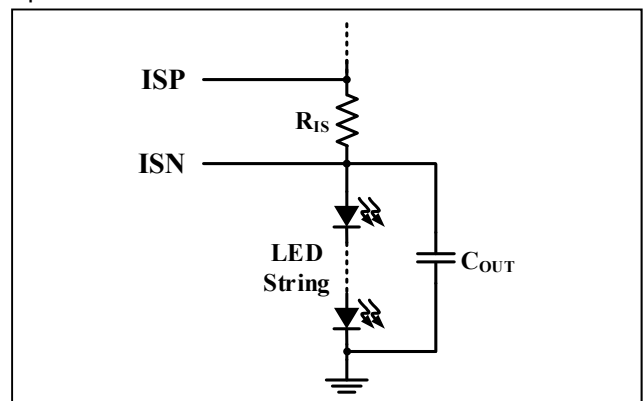

Figure 40 Output Capacitor Excluding R_{IS}

FREQUENCY SELECTION

During switching the IS32LT3961 operates in a constant on-time mode. The on-time is adjusted by the external resistor, R_{TON}, which is connected between the VCC and TON pins.

IS32LT3961

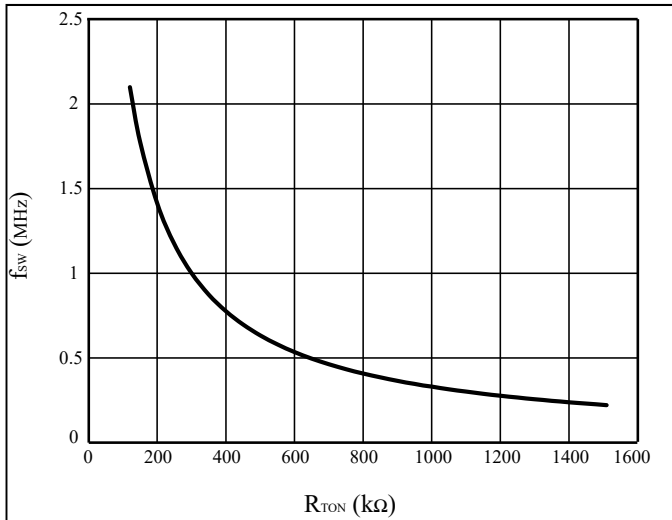

Figure 41 Operating Frequency vs. R_{TON} Resistance

The approximate operating frequency can be calculated by below Equation (7):

$$f_{SW} = \frac{I}{k \times (R_{TON} + R_{INT}) + 0.07} \quad (7)$$

Where $k = 0.0029$, with f_{SW} in MHz, R_{TON} and R_{INT} (internal resistance, 20kΩ) in kΩ.

Higher frequency operation results in smaller component size but increases the switching losses. It may also increase the high-side MOSFET gate driving current and may not allow sufficient high or low duty cycle. Lower frequency gives better performance but results in larger component size. In automotive applications, an operating frequency of 400kHz is good choice to compromise for both component size and efficiency, and keep the switching noise out of the sensitive frequency bands and easily pass EMI test.

SPREAD SPECTRUM

A switch mode controller can be troublesome when the EMI is concerned. To optimize the EMI performance, the IS32LT3961 includes a spread spectrum feature, which is a 500Hz with $\pm 10\%$ operating frequency jitter. The spread spectrum can spread the total electromagnetic emitting energy into a wider range that significantly degrades the peak energy of EMI. With spread spectrum, the EMI test can be passed with smaller size and lower cost filter circuit.

MINIMUM AND MAXIMUM OUTPUT VOLTAGE

The output voltage of a buck converter is approximately given as below:

$$V_{OUT} = V_{CC} \times D \quad (8)$$

Where D is the operating duty cycle.

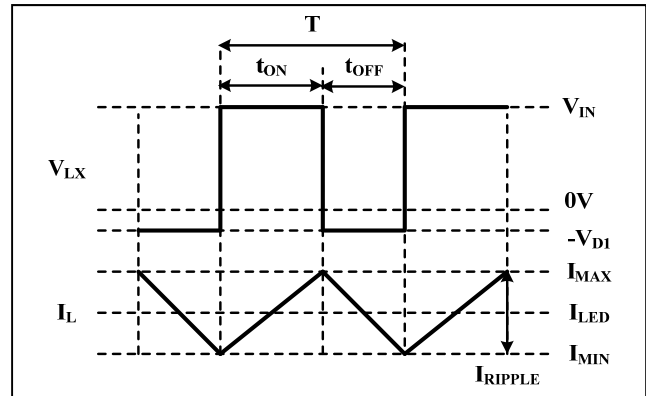

Figure 42 Operating Waveform

$$D = \frac{t_{ON}}{t_{ON} + t_{OFF}} \quad (9)$$

So,

$$V_{OUT} = V_{CC} \times \frac{t_{ON}}{t_{ON} + t_{OFF}} = V_{CC} \times t_{ON} \times f_{SW} \quad (10)$$

Where t_{ON} and t_{OFF} are the turn-on and turn off time of high-side MOSFET. Note that due to the spread spectrum, the f_{SW} should use the maximum of the operating frequency, $110\% \times f_{SW}$.

According to above equation, the output voltage depends on the operating frequency and the high-side MOSFET turn on time. When the frequency is set, the maximum output voltage is limited by the switching minimum off-time t_{OFF_MIN} , about 130ns. For example, if the input voltage is 12V and the operating frequency $f_{SW} = 1\text{MHz}$, the maximum output voltage is:

$$V_{OUT} = 12V \times (0.909\mu s - 130ns) \times 1.1\text{MHz} = 10.28V \quad (11)$$

Assume the forward voltage of each LED is 3.2V, the device can drive up to 3 LEDs in series.

The minimum output voltage is limited by the switching minimum on-time t_{ON_MIN} , about 130ns, since the frequency is set. For example, if the input voltage is 12V and the operating frequency $f_{SW} = 1\text{MHz}$, the minimum output voltage is:

$$V_{OUT} = 12V \times 130ns \times 1\text{MHz} = 1.72V \quad (12)$$

This means the device can drive a low forward voltage LED, such as a RED color LED. So under the condition of $V_{CC} = 12V$ and $f_{SW} = 1\text{MHz}$, the output voltage range is about 1.72V~10.28V. Exceeding this range, the operation will be clamped and the output current cannot reach the set value.

In a typical application, the output voltage is affected by other operating parameters, such as output current, R_{DS_ON} of the high-side MOSFET, DRC of the inductor, parasitic resistance of the PCB traces, and the forward voltage of the diode. Therefore, the output voltage range could vary from the calculation. The more precision equation is given by:

$$V_{OUT} = (V_{CC} - I_{LED} \times R_{DS_ON}) \times D - R_L \times I_{LED} - V_D \times (1 - D) \quad (13)$$

IS32LT3961

Where, R_{DS_ON} is the static drain-source on resistance of the high-side MOSFET, and R_L is the inductor DC resistance.

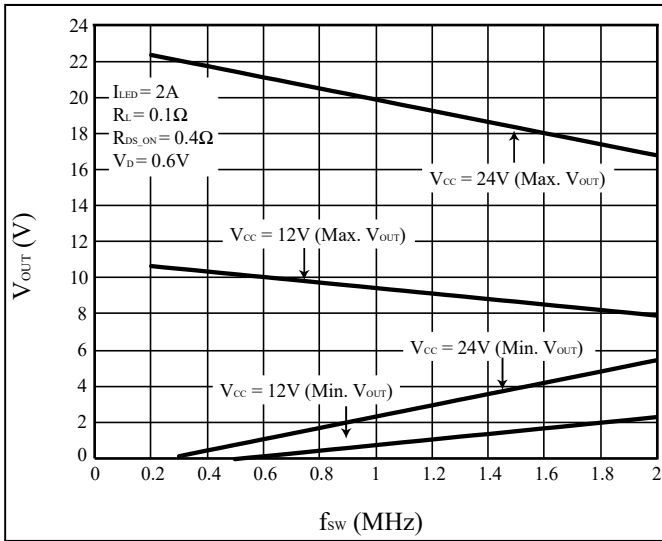

Figure 43 Minimum and Maximum Output Voltage versus Operating Frequency (minimum t_{ON} and t_{OFF} = 130ns)

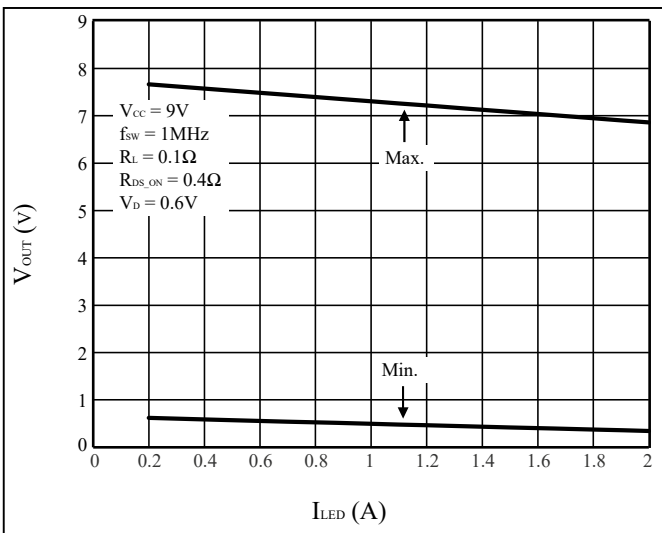

Figure 44 Minimum and Maximum Output Voltage versus LED Current (minimum t_{ON} and t_{OFF} = 130ns)

Figure 43 shows how the minimum and maximum output voltages vary with the operating frequency at 12V and 24V input. Figure 44 shows how the minimum and maximum output voltages vary with the LED current at 9V input (assuming $R_{DS_ON} = 0.4\Omega$, inductor DCR $R_L = 0.1\Omega$, and diode $V_D = 0.6V$). Note that due to spread spectrum the f_{SW} should use the maximum operating frequency, $110\% \times f_{SW}$.

When the output voltage is lower than the minimum t_{ON} time of the device, the device will automatically extend the operating t_{OFF} time to maintain the set output LED current all the time. However, the operating frequency will decrease accordingly to lower level to keep the duty cycle in correct regulating.

To achieve wider output voltage range and flexible output configuration, a lower operating frequency

should be considered.

HIGH-SIDE MOSFET PEAK CURRENT LIMIT

To protect itself, the IS32LT3961 integrates an Over Current Protection (OCP) detection circuit to monitor the current through the high-side MOSFET during switching on. Whenever the current exceeds the OCP current threshold, I_{SWLIM} , the device will immediately turn off the high-side MOSFET for t_{OCP} and restart again. The device will remain in this hiccup mode until the current drops below I_{SWLIM} .

INDUCTOR

Inductor value involves trade-offs in performance. A larger inductance reduces inductor current ripple, however it also brings in unwanted parasitic resistance that degrades the efficiency. A smaller inductance has compact size and lower cost, but introduces higher ripple in the LED string. Use the following equation to estimate the approximate inductor value:

$$L = \frac{(V_{CC} - V_{LED}) \times V_{LED}}{f_{SW} \times \Delta I_L \times V_{CC}} \quad (14)$$

Where V_{CC} is the minimum input voltage in volts, V_{LED} is the total forward voltage of LED string in volts, f_{SW} is the operation frequency in hertz and ΔI_L is the current ripple in the inductor. Select an inductor with a rated current greater than the output average current and the saturation current over the Over Current Protection (OCP) current threshold I_{SWLIM} .

Since the IS32LT3961 is a Continuous Conduction Mode (CCM) buck driver which means the valley of the inductor current, I_{MIN} , should not drop to zero at any time, the ΔI_L must be smaller than 200% of the average output current.

$$I_{MIN} = I_{LED} - \frac{\Delta I_L}{2} > 0 \quad (15)$$

Besides, the peak current of the inductor, I_{MAX} , must be smaller than I_{SWLIM} and I_{L_LIM} to prevent the IS32LT3961 from triggering OCP, especially when the output current is set to a high level.

$$I_{MAX} = I_{LED} + \frac{\Delta I_L}{2} < I_{SWLIM} \quad (16)$$

$$I_{MAX} = I_{LED} + \frac{\Delta I_L}{2} < I_{L_LIM} \quad (17)$$

To ensure system stability, the ΔI_L must be higher than 10% of the average output current. There is no hard limit on the highest current ripple percentage allowed. However, to get better current accuracy and analog dimming performance, it is recommended to choose an inductor current ripple ΔI_L between 10% and 50% of the average output current.

$$0.1 \times I_{LED} \leq \Delta I_L \leq 0.5 \times I_{LED} \quad (18)$$

IS32LT3961

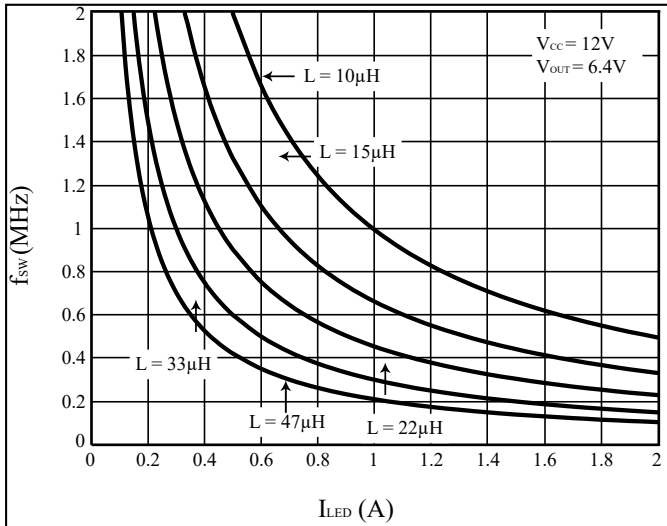

Figure 45 Inductance Selection Based On 30% Current Ripple

Figure 45 shows inductor selection based on the operating frequency and LED current at 30% inductor current ripple. If a lower operating frequency is used, either a larger inductance or current ripple should be used.

DIODE

The IS32LT3961 is a non-synchronous buck driver that requires a recirculating diode to conduct the current during the high-side MOSFET off time. The best choice is a Schottky diode due to its low forward voltage, low reverse leakage current and fast reverse recovery time. The diode should be selected with a peak current rating above the inductor peak current and a continuous current rating higher than the maximum output load current. It is very important to consider the reverse leakage of the diode when operating at high temperature. Excess leakage will increase the power dissipation on the device.

The higher input voltage and the voltage ringing due to the reverse recovery time of the Schottky diode will increase the peak voltage on the LX output. If a Schottky diode is chosen, care should be taken to ensure that the total voltage appearing on the LX pin including supply ripple, does not exceed its specified maximum value.

FAULT HANDLING

The IS32LT3961 is designed to detect the following faults and report via open drain FAULTB pin:

- Pin open
- Pin-to-ground short
- Pin-to-neighboring pin short
- Output LED string open and short
- Single LED short
- External component open or short
- Thermal shutdown

Please check Table 2 for the details of the fault actions.

Note that the FAULTB pin is an open drain structure. If it is monitored by a host, an external pull up resistor R_{PU} from the supply of the host to FAULTB pin is needed. The recommended R_{PU} value is 10k Ω .

CALCULATING RANGE OF R_{PU}

The ideal value for R_{PU} range needs to take into account the number of IS31LT3961 devices connected to the same host. The resulting R_{PU} voltage level should not interfere with the V_{IH_HOST} and V_{IL_HOST} detection levels of the host. For no-fault detected operation, the sum of the leakage current(s) for the open drain (if more than one device interconnected) multiplied with the value of R_{PU} must be greater than V_{IH_HOST} . For fault detected operation, the pull down voltage must be below V_{IL_HOST} . Then

$$R_{PU_MAX} = \frac{V_{HOST} - V_{IH_HOST}}{N \times I_{LK_FAULTB}} \quad (19)$$

$$R_{PU_MIN} = \frac{(V_{HOST} - V_{IL_HOST}) \times V_{FAULTB}}{N \times V_{IL_HOST} \times I_{OL}} \quad (20)$$

Where N is the number of IS31LT3961 devices connected to the same host. I_{OL} is the test condition of FAULTB pin pull down capability. It can be found in the EC table.

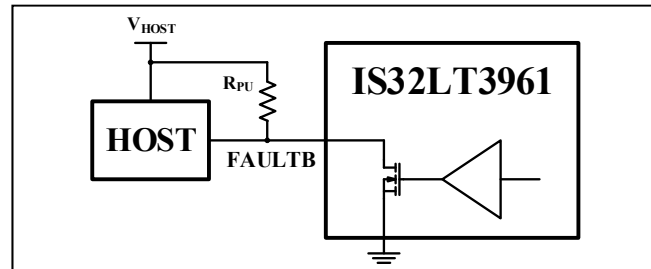

Figure 46 Host Monitors The Fault Reporting

LED SHORT CIRCUIT DETECTION

The IS32LT3961 features LED short circuit detection, including whole LED string shorted and single LED shorted, using a resistor divider on SCD pin.

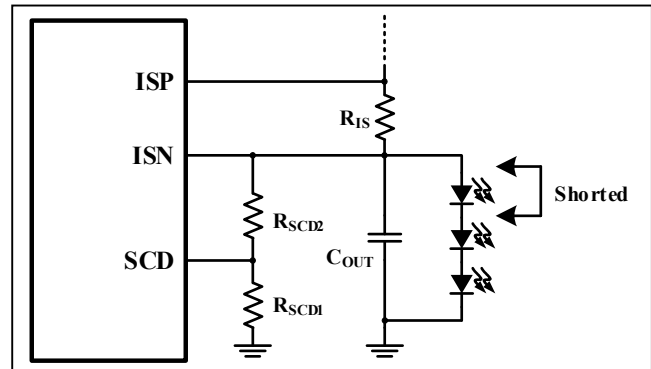

Figure 47 Single LED Short Detection

In the case of either the entire LED string shorted or any single LED shorted cause the SCD pin voltage to drop below the threshold voltage V_{SCD_TH} and persist for

IS32LT3961

t_{DELAY1} , the FAULTB pin pulls low to report the fault condition and the output current keeps normal regulation. In multiple LEDs in series applications, choose the R_{SCD1} and R_{SCD2} resistor divider as following equation to realize single LED short detection:

$$(N-I) \times V_{F_MAX} < V_{SCD_TH} \times \frac{R_{SCD1} + R_{SCD2}}{R_{SCD1}} < N \times V_{F_MIN} \quad (21)$$

Where, N is the number of LEDs in the string. V_{F_MAX} and V_{F_MIN} are the maximum and minimum forward voltage of a single LED. Recommend choosing 10k Ω for the R_{SCD1} and calculate the R_{SCD2} according to above equation. The resistors R_{SCD1} and R_{SCD2} should be a 1% resistor with good temperature characteristic to ensure accurate detection.

Once the short circuit fault condition is removed and the SCD pin voltage rises above $(V_{SCD_TH} - V_{SCD_HY})$, the FAULTB pin will resume to high impedance after t_{DELAY2} .

Never leave the SCD pin floating. If the LED short circuit detection is unused, the SCD pin should be connected to ISN pin via a resistor (recommended value is 10k Ω).

OUTPUT CURRENT MONITOR

The IMON pin voltage represents the output current measured by the voltage across the output current sense resistor R_{IS} . It can be connected to an external host to implement output status tracking. The linear relationship between the IMON output voltage and the voltage across R_{IS} is:

$$V_{IMON} = (V_{ISP} - V_{ISN}) \times 8 + 0.4V \quad (22)$$

The maximum output voltage of the IMON pin can be up close to V_{DD} , 6V. If the voltage rating of the host's I/O is lower than 6V, a resistor divider can be used to decay the IMON pin output voltage. The recommended resistor divider value is several ten k Ω .

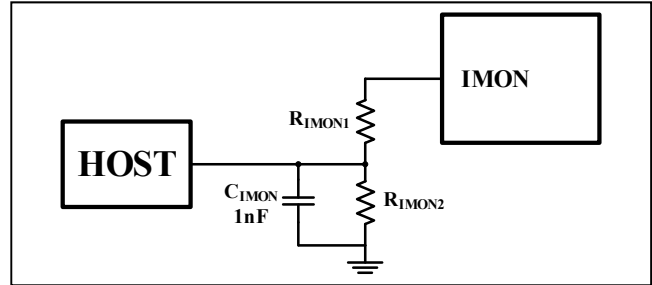

Figure 48 IMON to Host

THERMAL SHUTDOWN PROTECTION

To protect the IC from damage due to high power dissipation, the temperature of the die is monitored. If the die temperature exceeds the thermal shutdown temperature of 170 $^{\circ}C$ (Typ.) then the device will shut down, and the output current is shut off and FAULTB pin pulls low. After a thermal shutdown event, the IS32LT3961 will not try to restart until its temperature has reduced to less than 150 $^{\circ}C$ (Typ.). The FAULTB pin will recover once the IC restarts.

Table 2 Fault Actions

Fault Type	LED String	Detect Condition		FAULTB Pin		Fault Recovering
Inductor shorted	Dim	Trigger OCP. Turn off high-side MOSFET immediately. Retry after 10ms.		Pull Low immediately		Inductor shorted removed. No OCP triggered and FAULTB pin recover after 10ms.
R_{IS} shorted	Dim	Trigger OCP. Turn off high-side MOSFET immediately. Retry after 10ms.		Pull Low immediately		R_{IS} shorted removed. No OCP triggered and FAULTB pin recover after 10ms.
R_{IS} open	Off	Detect high differential sense voltage. Turn off high-side MOSFET immediately. Retry after 10ms.		Pull Low after 20us deglitch time.		R_{IS} open removed. FAULTB pin recover after 10ms.
LED string open	Off	No PWM dimming:	Low R_{IS} voltage trigger EAO high-clamp for 10ms.	No PWM dimming:	Pull Low after 10ms.	LED open removed. FAULTB pin recover after 10ms.
		PWM dimming:	Low R_{IS} voltage trigger EAO high-clamp after 20us deglitch time and keeps for 16 PWM cycles.	PWM dimming:	Pull low after 16 PWM cycles.	
LED string partially shorted (including single LED shorted)	Shorted LEDs are off	No PWM dimming:	$V_{SCD} < 1.15V$ last for 10ms	No PWM dimming:	Pull Low after 10ms.	Shorted removed. $V_{SCD} > 1.2V$ for 10ms and FAULTB pin recover.
		PWM dimming:	$V_{SCD} < 1.15V$ after 20us deglitch time and keeps for 16 PWM cycles.	PWM dimming:	Pull low after 16 PWM cycles.	
LED string/ LED cap shorted to GND	Off	No PWM dimming:	$V_{SCD} < 1.15V$ last for 10ms	No PWM dimming:	Pull Low after 10ms.	Shorted removed. $V_{SCD} > 1.2V$ for 10ms and FAULTB pin recover.
		PWM dimming:	$V_{SCD} < 1.15V$ after 20us deglitch time and keeps for 16 PWM cycles.	PWM dimming:	Pull low after 16 PWM cycles.	

IS32LT3961

Table 2 Fault Actions (Continue)

Fault Type	LED String	Detect Condition	FAULTB Pin		Fault Recovering
BOOT capacitor open	Dim	$V_{CC}-V_{LX}>2V$ at high-side MOSFET ON (High-side can't fully turn on). Turn off high-side MOSFET immediately. Retry after 10ms.	Pull Low immediately		BOOT capacitor open removed. $V_{CC}-V_{LX}<2V$ for 10ms and FAULTB pin recover.
BOOT capacitor shorted	Off	Bootstrap circuit UVLO and turn off high-side MOSFET immediately.	No PWM dimming:	Pull Low after 10ms.	BOOT capacitor shorted removed. Release from UVLO and FAULTB pin recover after 10ms
			PWM dimming:	Pull low after 16 PWM cycles.	
R_{TON} resistor open	Dim	On-time exceeds 20 μ s or trigger OCP, then turn off high-side MOSFET immediately. Retry after 10ms.	Pull Low immediately		R_{TON} resistor open removed. No over 20us on-time or OCP triggered. FAULTB pin recover after 10ms
R_{TON} resistor shorted	Dim	The device operating at minimum on/off time, maybe trigger the other fault conditions.	No reporting		R_{TON} resistor shorted removed.
Diode short	Off	Trigger OCP. Turn off high-side MOSFET immediately. Retry after 10ms.	Pull Low immediately		Diode shorted removed. No OCP triggered and FAULTB pin recover after 10ms.
Diode open	Dim	$V_{LX}<-1.1V$. turn off high-side MOSFET immediately. Retry after 10ms.	Pull Low immediately		Diode open removed. FAULTB pin recover after 10ms.
VOUT/ISP short to GND	Off	Trigger OCP. Turn off high-side MOSFET immediately. Retry after 10ms.	Pull Low immediately		Shorted removed. FAULTB pin recover after 10ms.
R_{CS} open	Dim	$V_{LX}<-1.1V$. turn off high-side MOSFET immediately. Retry after 10ms.	Pull Low immediately		R_{CS} open removed. FAULTB pin recover after 10ms.
Thermal Shutdown	Off	The die temperature exceeds 170°C	Pull Low immediately		The die temperature cools down below 150°C. FAULTB pin recovers immediately.

LAYOUT CONSIDERATIONS

As for all switching power supplies, especially those providing high current and using high switching frequencies, layout is an important design step. If layout is not carefully done, the operation could show instability as well as EMI problems.

The high dV/dt surface and dI/dt loops are big noise emission source. To optimize the EMI performance, keep the area size of all high switching frequency points with high voltage compact. Meantime, keep all traces carrying high current as short as possible to minimize the loops.

- (1) Wide traces should be used for connection of the high current paths that helps to achieve better efficiency and EMI performance. Such as the traces of power supply, inductor L_1 , current recirculating diode D_1 , current sense resistor R_{IS} and R_{CS} , LED load and ground.
- (2) Keep the traces of the switching points shorter. The inductor L_1 , LX and current recirculating diode D_1 should be placed as close to each other as possible and the traces of connection between them should be as short and wide as possible.
- (3) To avoid the ground jitter, the components of parameter setting should be placed close to the corresponding pins and return to the AGND pin, and keep the traces length to the pins as short as possible. On the other side, to prevent the noise

coupling, the traces of R_{IS} should either be far away or be isolated from high-current paths and high-speed switching nodes. These practices are essential for better accuracy and stability.

- (4) The ground of the current sense resistor, R_{CS} , should be directly connected to SGND pin to ensure precise sensing.
- (5) The capacitors C_{VCC} and C_{VDD} should be placed as close as possible to VCC and VDD pins for good filtering.
- (6) Place the bootstrap capacitor C_{BOOT} close to BOOT pin and LX pin to ensure the traces as short as possible.
- (7) The connection to the LED string should be kept short to minimize radiated emission. An output capacitor C_{OUT} is recommended to be used and placed on driver board to reduce the current ripple in the connecting cables.
- (8) In practice, if the LED string is far away from the driver board and connected through long cables, the parasitic inductance in the cables will form a LC-resonant circuit with the C_{OUT} . In the case of hot plugging the output connector or an unreliable connector, this LC-resonant circuit will create oscillation on ISN and ISP pins due to the C_{OUT} fast discharging. This oscillation could subject the ISN and ISP pins to negative spike voltage exceeding their Absolute Maximum Ratings that may

IS32LT3961

permanently damage the ISN and ISP pins. To avoid the negative spike voltage, please consider adding a Schottky diode D_P in parallel with the C_{OUT} . Recommend a 60V/1A Schottky diode for D_P .

Note that hot plugging the output connector is a non-standard operation. Please avoid it during mass-production. And the connecting reliability of the output connector must be ensured as well.

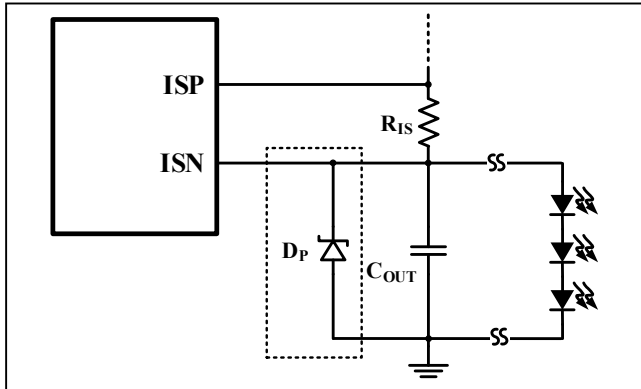

Figure 49 Schottky Diode for Hot Plugging Protection

- (9) The thermal pad on the back of device package must be soldered to a sufficient size of copper ground plane with sufficient vias to conduct the heat to opposite side PCB for adequate cooling.

THERMAL CONSIDERATIONS

The package thermal resistance, θ_{JA} , determines the amount of heat that can pass from the silicon die to the surrounding ambient environment. The θ_{JA} is a measure of the temperature rise created by power dissipation and is usually measured in degree Celsius per watt ($^{\circ}C/W$).

When operating the chip at high ambient temperatures, or when driving maximum load current, care must be taken to avoid exceeding the package power dissipation limits. The maximum power dissipation can be calculated using the following Equation (23):

$$P_{D(MAX)} = \frac{T_{J(MAX)} - T_A}{\theta_{JA}} \quad (23)$$

Where $T_{J(MAX)}$ is the recommended maximum operating junction temperature.

So,

$$P_{D(MAX)} = \frac{150^{\circ}C - 25^{\circ}C}{45.6 \frac{^{\circ}C}{W}} \approx 2.74W$$

Figure 50, shows the power derating of the IS32LT3961 on a JEDEC boards (in accordance with JESD 51-5 and JESD 51-7) standing in still air.

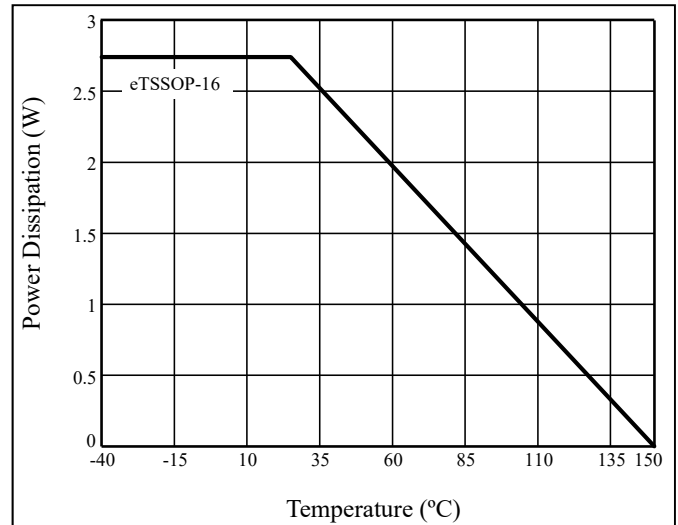

Figure 50 Dissipation Curve

The thermal resistance is achieved by mounting the IS32LT3961 on a standard FR4 double-sided printed circuit board (PCB) with a copper area of a few square inches on each side of the board under the IS32LT3961. Multiple thermal vias, as shown in Figure 51, help to conduct the heat from the exposed pad of the IS32LT3961 to the copper on each side of the board. The thermal resistance can be reduced by using a metal substrate or by adding a heatsink.

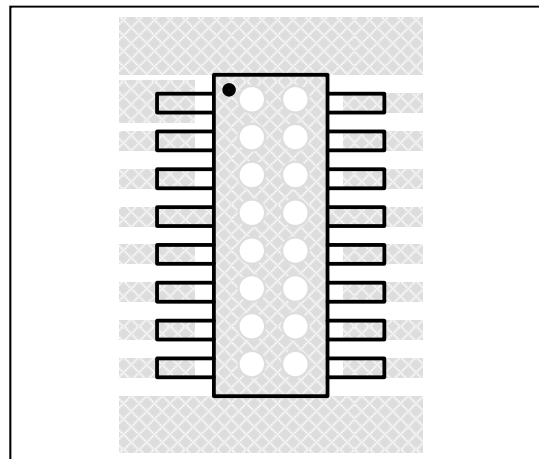

Figure 51 Board Via Layout For Thermal Dissipation

IS32LT3961

CLASSIFICATION REFLOW PROFILES

Profile Feature	Pb-Free Assembly
Preheat & Soak Temperature min (T _{smin}) Temperature max (T _{smax}) Time (T _{smin} to T _{smax}) (t _s)	150°C 200°C 60-120 seconds
Average ramp-up rate (T _{smax} to T _p)	3°C/second max.
Liquidous temperature (T _L) Time at liquidous (t _L)	217°C 60-150 seconds
Peak package body temperature (T _p)*	Max 260°C
Time (t _p)** within 5°C of the specified classification temperature (T _c)	Max 30 seconds
Average ramp-down rate (T _p to T _{smax})	6°C/second max.
Time 25°C to peak temperature	8 minutes max.

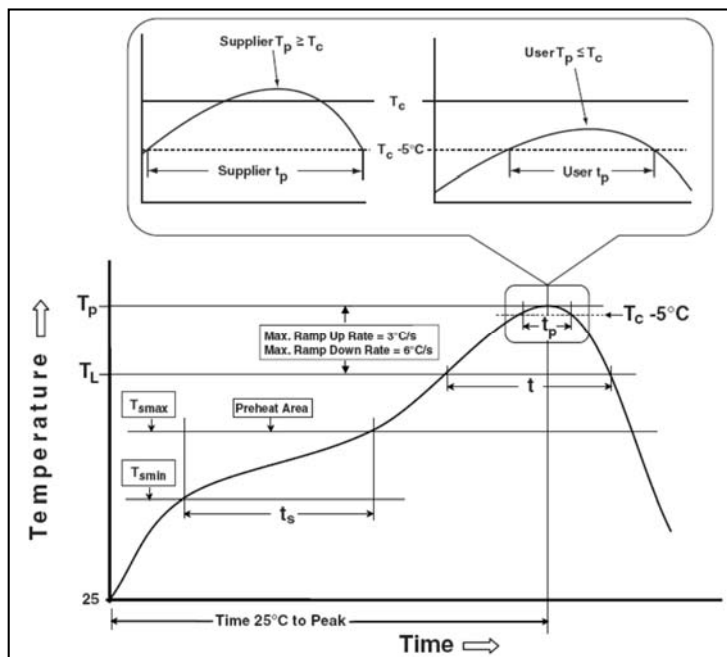
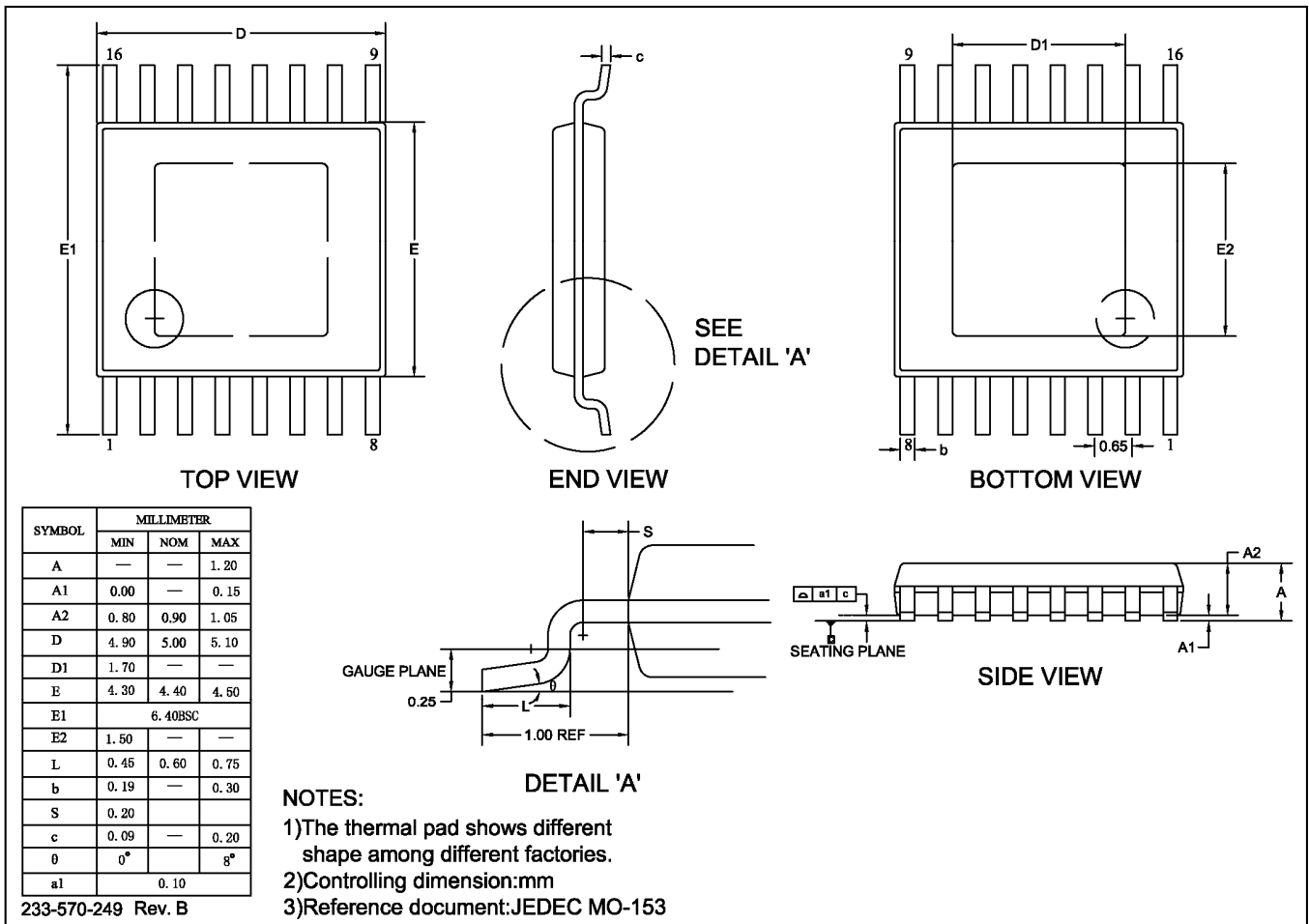

Figure 52 Classification Profile

IS32LT3961

PACKAGE INFORMATION

eTSSOP-16



IS32LT3961

RECOMMENDED LAND PATTERN

eTSSOP-16

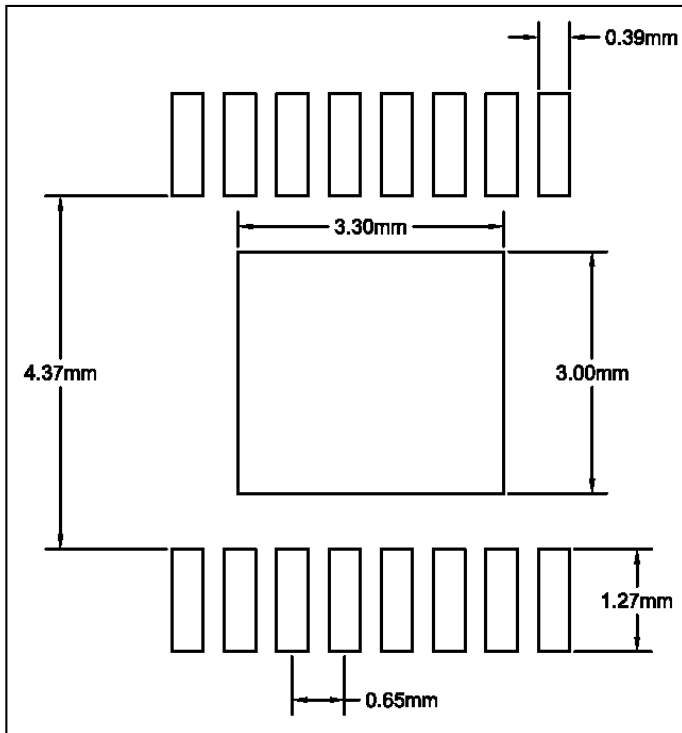

Note:

1. Land pattern complies to IPC-7351.
2. All dimensions in MM.
3. This document (including dimensions, notes & specs) is a recommendation based on typical circuit board manufacturing parameters. Since land pattern design depends on many factors unknown (eg. user's board manufacturing specs), user must determine suitability for use.