

ISL1571IRZ-EVAL

The ISL1571IRZ-EVAL evaluation board is designed to provide a quick and easy method for evaluating the [ISL1571](#). The ISL1571 is a high-speed current feedback differential amplifier used in a single port Power Line Communication (PLC) application.

Features

- Achieves -50dBc average MTPR distortion driving a 50MHz PLC signal
- Full, medium, low, and disable power settings

Specifications

This board is optimized for the following operating conditions:

- Nominal Supply Voltage = $\pm 6V$ or $+12V$
- Bias Voltages at pins Bias 0 and Bias 1:
 $V_{IH(min)} = 2V$, $V_{IL(max)} = 0.8V$
- Signal Bandwidth: 35kHz to 190MHz

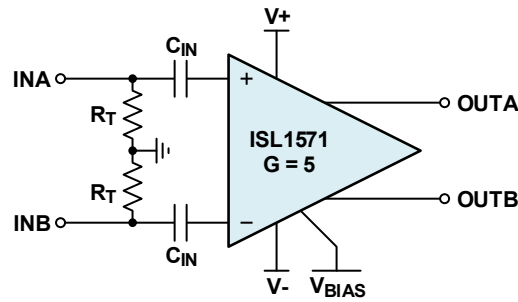

Figure 1. ISL1571IRZ-EVAL Block Diagram

Contents

1. Functional Description	3
1.1 Gain Setting	3
1.2 Operating Conditions	3
1.3 Evaluation Set Up	3
2. Board Design	4
2.1 PCB Layout Guidelines	5
2.2 Schematic Drawing	5
2.3 Bill of Materials	6
2.4 Board Layout	7
3. Typical Performance Graphs	8
4. Ordering Information	8
5. Revision History	8

1. Functional Description

1.1 Gain Setting

The ISL1571IRZ evaluation board is set to a gain of 5V/V. The gain can be adjusted by changing RCG.

$$(EQ. 1) \quad A_V = 1 + \frac{RFA}{0.5 \times RCG}$$

1.2 Operating Conditions

The ISL1571IRZ is designed to operate on a nominal supply of $\pm 6V$ or $+12V$. The C0 and C1 control pins are used to bias the operating supply current of the ISL1571IRZ. [Table 1](#) summarizes the four power modes and the typical supply current for each mode. The minimum voltage to set C0 and C1 pins high is 2V and the maximum voltage to set C0 and C1 pins low is 0.8V.

Table 1. Operating Power Modes

Power Modes	C0	C1	Supply Current per Port
Full Power	0	0	30mA
Medium Power	1	0	22mA
Low Power	0	1	12mA
Disable	1	1	1.2mA

1.3 Evaluation Set Up

1. Connect +12V to +VS pin and ground to -VS and GND pin.
2. Turn on the power supply and the quiescent supply current in full power mode for the two amplifiers should read 30mA.
3. Apply a 1MHz differential sine wave signal from -0.25V to +0.25V ($0.5V_{P-P}$) to INA and INB. $1V_{P-P}$ differential across INA-INB.
4. With an oscilloscope, probe OUTA (Pin 16) or OUTB (Pin 13) with a high impedance ($10M\Omega$) probe and verify correct output voltage. Each output has $\pm 1.25V$ ($2.5V_{P-P}$). $5V_{P-P}$ differential across Pin 16 and Pin 13.

2.1 PCB Layout Guidelines

C2 and C4 are small ceramic signal decoupling capacitors and C1 and C3 are tantalum power supply decoupling capacitors. Renesas recommends placing the decoupling capacitors close to the supply pins. **Note:** Be careful of the polarities of C1 and C3 because it can be set to either positive or negative. Place RFA and RFB as close as possible to the inverting and output pins to keep the feedback loop minimal. See the ISL1571IRZ datasheet for the appropriate feedback and gain settings.

2.2 Schematic Drawing

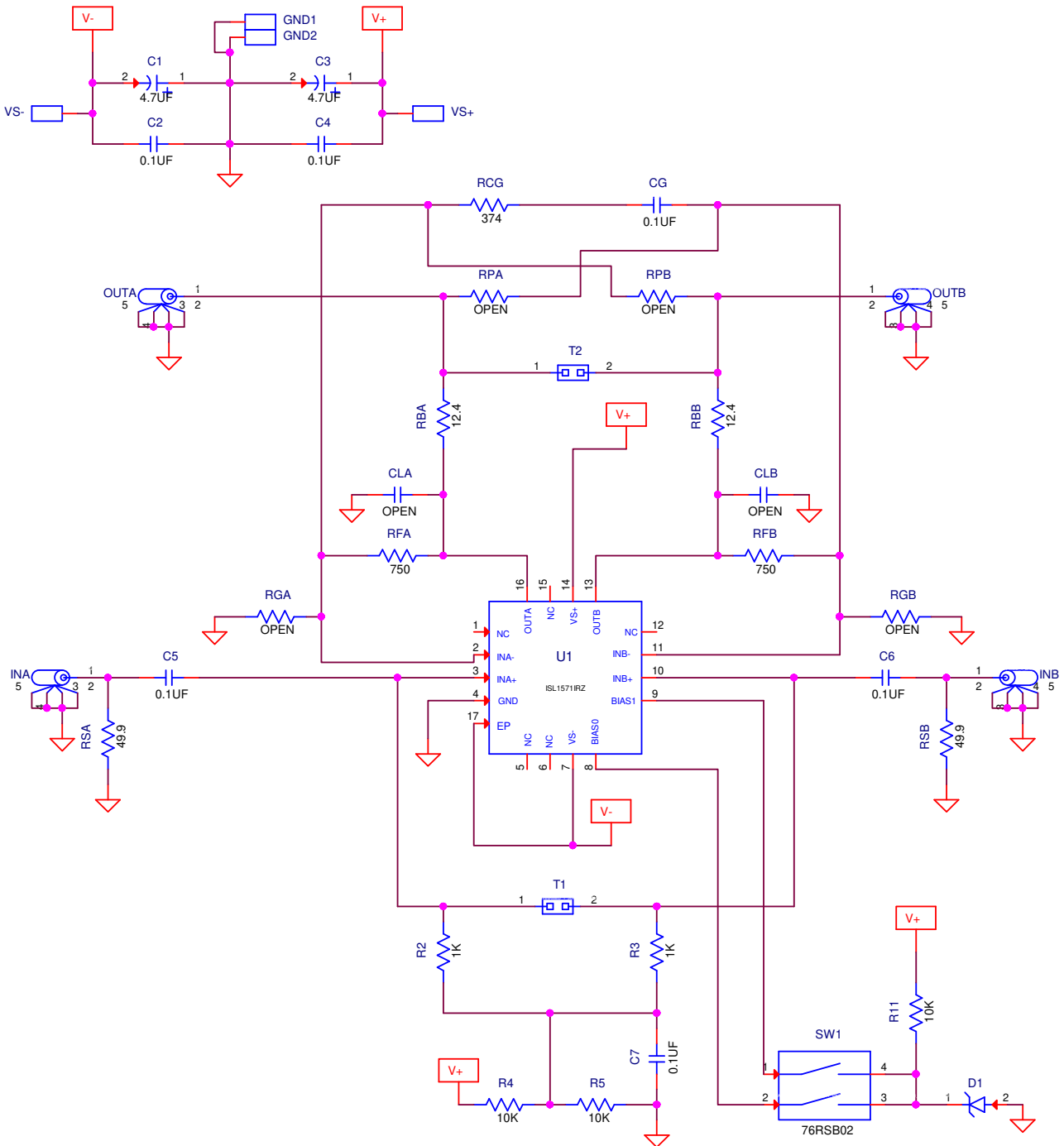

Figure 4. Schematic

2.3 Bill of Materials

Qty	Reference Designator	Description	Manufacturer	Manufacturer Part
1		PWB-PCB, ISL1571IRZEVALZ, REVA, ROHS	Imagineering Inc	ISL1571IRZEVALZREVAPCB
6	C2, C4, C5, C6, C7, CG	CAP, SMD, 0805, 0.1 μ F, 50V, 5%, X7R, ROHS	Kemet	C0805C104J5RACTU
0	CLA, CLB	CAP, SMD, 0805, DNP-PLACE HOLDER, ROHS		
2	C1, C3	CAP TANT, SMD, C, 4.7 μ F, 25V,10%, ROHS	Kemet	T491C475K025AT
4	VS+, VS-, GND1, GND2	CONN-GEN, TURRET, UNINSUL, 0.076 MNT.HOLE, ROHS	Cambion	160-2044-02-01-00
4	INA, INB, OUTA, OUTB	CONN-BNC, RECEPTACLE, TH, 4 POST, 50 Ω , SILVERCONTACT, ROHS	Amphenol	31-5329-51RFX
2	T1,T2	CONN-HEADER, 1x2, RETENTIVE, 2.54mm,0.230x0.120, ROHS	BERG/FCI	69190-202HLF
1	D1	DIODE-ZENER, SMD, SOD-80 MiniMELF, 5.1V, 5%, 0.5W, ROHS	Vishay	TZM5231B-GS08
1	U1	IC-POWER LINE COMMUNICATION, 16P, QFN, ROHS	Renesas Electronics	ISL1571IRZ-T7
2	R2, R3	RES, SMD, 0805, 1k, 1/8W, 1%, TF, ROHS	Venkel	CR0805-8W-1001FT
3	R4, R5, R11	RES, SMD, 0805, 10k, 1/8W, 1%, TF, ROHS	Venkel	CR0805-8W-1002FT
1	RCG	RES, SMD, 0805, 374 Ω , 1/8W, 1%, TF, ROHS	Yageo	RC0805FR-07374RL
2	RBA, RBB	RES, SMD, 0805, 12.4 Ω , 1/8W, 1%, TF, ROHS	Rohm	MCR10EZHF12R4
2	RSA, RSB	RES, SMD, 0805, 49.9 Ω , 1/8W, 1%, TF, ROHS	Rohm	MCR10EZHF49R9
2	RFA, RFB	RES, SMD, 0805, 750 Ω , 1/8W, 1%, TF, ROHS	Panasonic	ERJ-6ENF7500V
0	RGA, RGB, RPA, RPB	RES, SMD, 0805, DNP-PLACE HOLDER, ROHS		
1	SW1	SWITCH-DIP, ROCKER, TH, 2POS, SPST, 150mA, 300V _{DC} , ROHS	Grayhill	76RSB02ST
4	Four Corners	SCREW, 4-40x1/4in, PHILLIPS, PANHEAD, STAINLESS, ROHS	Building Fasteners	PMSSS 440 0025 PH
4	Four Corners	STANDOFF, 4-40x3/4in, F/F, HEX, ALUMINUM, 0.25 OD, ROHS	Keystone	2204

3. Typical Performance Graphs

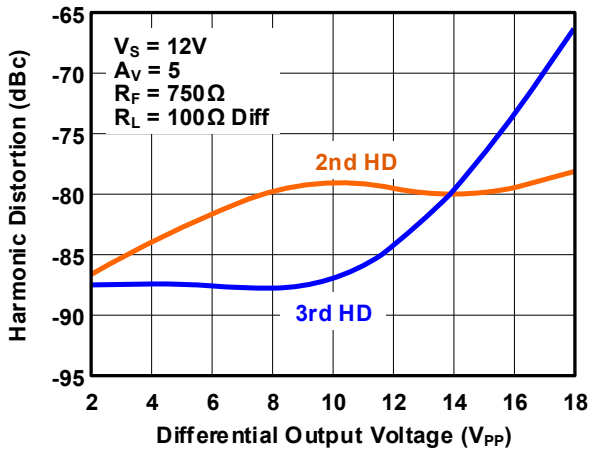

Figure 9. Harmonic Distortion at 10MHz (Full Bias Mode)

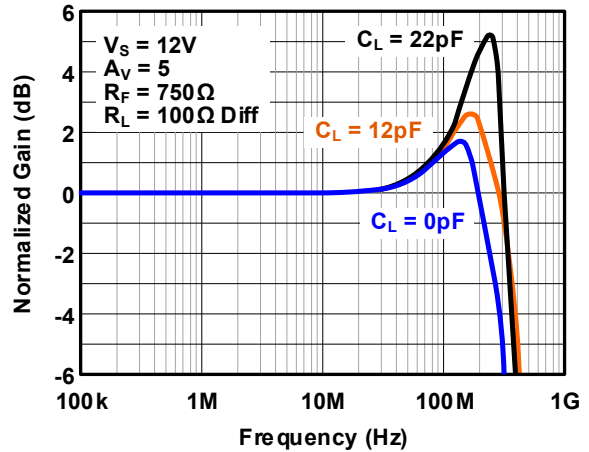

Figure 10. Frequency Response with Various C_L (Full Bias Mode)

4. Ordering Information

Part Number	Description
ISL1571IRZ-EVAL	ISL1571 evaluation board

5. Revision History

Rev.	Date	Description
1.01	Mar 31, 2021	Applied new template. Updated the schematic and BOM for RBA, RBB, RSA, and RSB.
1.00	Sep 23, 2020	Initial release