

ISL21090xxEV1Z

Evaluation Boards

AN1764

Rev 1.00

February 25, 2013

Introduction

The ISL21090XXEV1Z evaluation board is designed to measure the performance of the high precision ISL21090 voltage reference. The reference has a wide input voltage range from the individual threshold voltage to 36V and an initial accuracy of 0.02% to 0.035%. The voltage noise of 1µV_{p-p} in the 0.1Hz to 10Hz range (1.25V option) and maximum output voltage temperature coefficient of 7 ppm/°C make the ISL21090 ideal for high end applications.

The evaluation board includes voltage input test points (VIN and GND) for a power supply input, as well as a pair of test points for the output (VOUT and GND). Additionally, a jumperable R-C damper network can connect to VOUT (J1), and R2 accepts surface mount or through-hole style resistors for output load testing.

Reference Documents

- ISL21090 Datasheet [FN6993](#)

TABLE 1. ORDERING INFORMATION

BOARD NUMBER	OUTPUT VOLTAGE (V)	TYPE
ISL2109012EV1Z	1.25	Evaluation Board
ISL2109025EV1Z	2.5	Evaluation Board
ISL2109050EV1Z	5.0	Evaluation Board
ISL2109075EVAL1Z	7.5	Evaluation Board

ISL21090XXEV1Z Board

The schematic of the evaluation board is shown in Figure 5. The ISL21090XXEV1Z contains the ISL21090 voltage reference (U1), input decoupling capacitors (C1, C2), a compensation capacitor (C5), and a load capacitor (C3).

The power supply leads attach to TP1 and TP2 (VIN, GND). The output is measured at test points TP3 and TP4 (VOUT, GND), and is best measured with a high quality voltmeter.

The R-C damper network is populated and can be connected to the reference output by adding a shunt to the R-C jumper (J1). The damper network improves stability by reducing transient load ringing with high value (>0.47µF) capacitors.

TABLE 2. COMPONENTS PARTS LIST

DEVICE #	VALUE	DESCRIPTION
C1	10µF	Bypass Capacitor
C2	0.01µF	Bypass Capacitor
C3	0.1µF	Load Capacitor
C4	10µF	Damper Capacitor
C5	1nF	Compensation Capacitor
R1	2.21kΩ	Damper Resistor
R2	DNP	Optional Load Resistor
U1	ISL21090	SOIC 8-Pin Package
J1	DNP	Damper Jumper

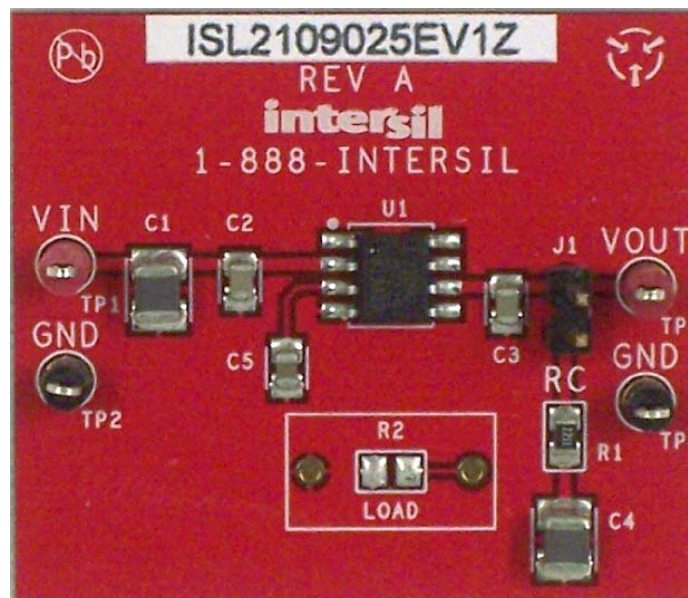

FIGURE 1. VOLTAGE REFERENCE EVALUATION BOARD

Voltage Reference Evaluation Board Layout

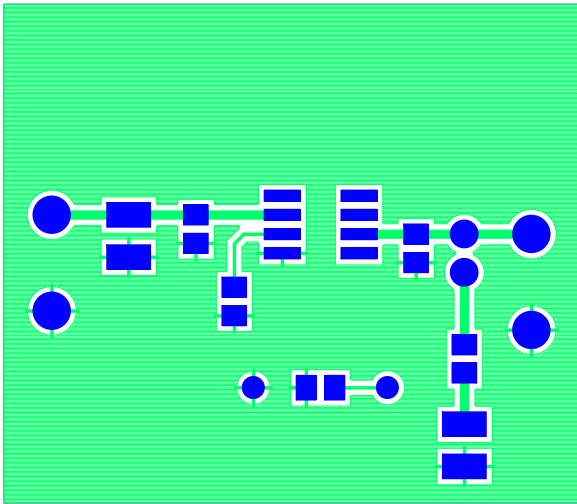

FIGURE 2. TOP COMPONENTS

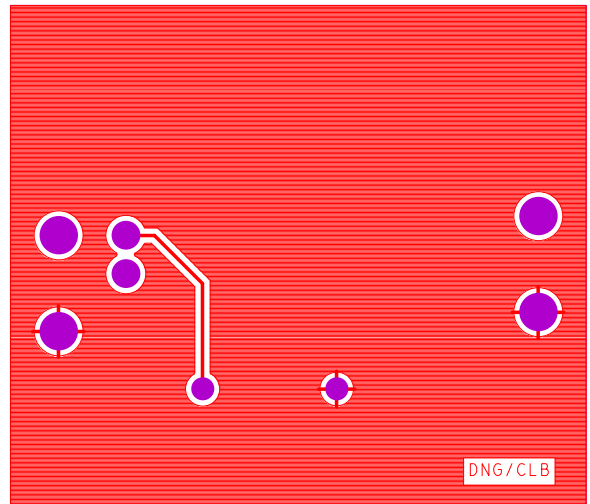

FIGURE 3. BOTTOM LAYER

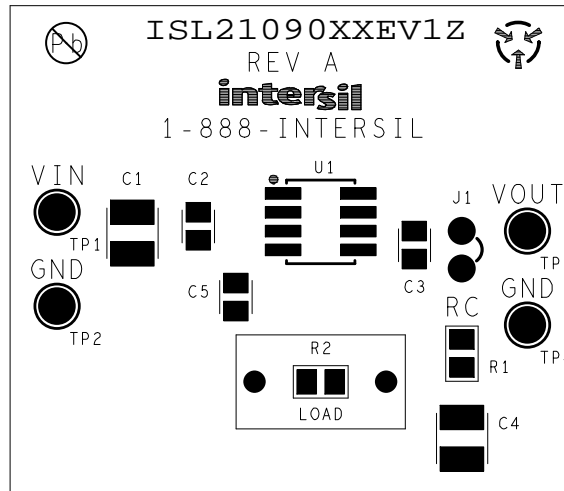

FIGURE 4. ASSEMBLY DRAWING

ISL21090XXEV1Z Schematic

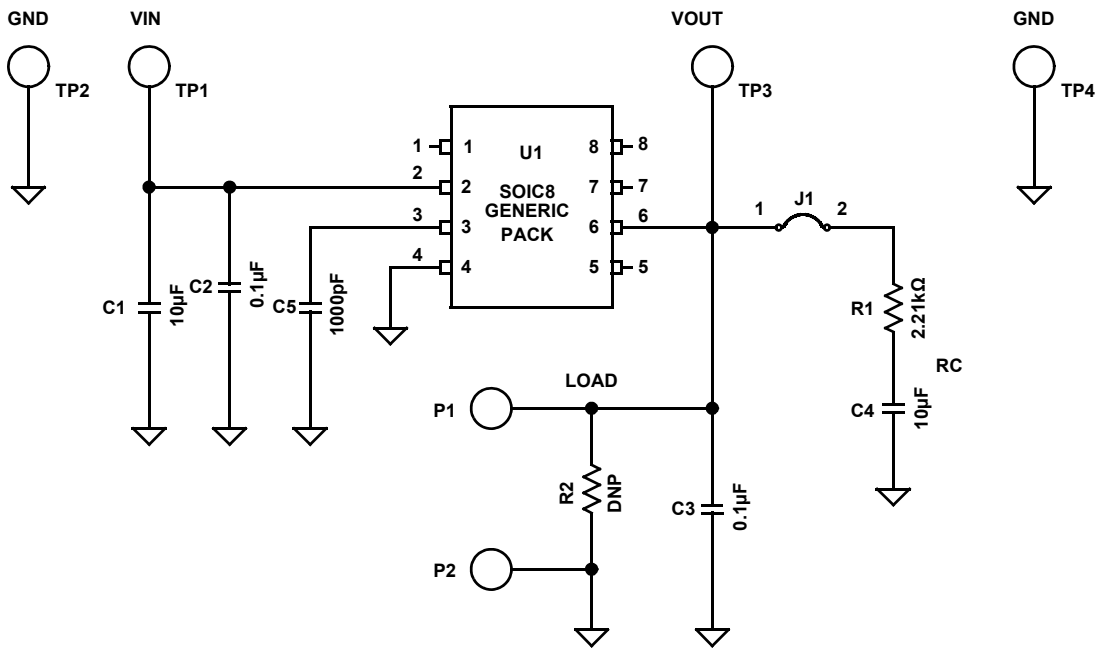

FIGURE 5. SCHEMATIC