

ISL28006xEVAL1Z

The ISL28006 evaluation board is a design platform containing all the circuitry needed to characterize critical performance parameters of the ISL28006 in either a high side or low-side current sense application. The ISL28006 is available in fixed 100V/V, 50V/V, 20V/V and adjustable gains.

Features

- One installed sense resistor: 100mΩ, 1W, 1%
- Option for fixed-gain or adjustable-gain version
- Connectors for direct connections to external system supply and load resistor
- Options for four more on-board sense resistors
- Options for additional input and output filter resistors and capacitors

Specifications

- Low Power Consumption: 50μA,Typ
- Supply Range on VS+: 2.7V to 28V
- Wide Common Mode Input: 0V to 28V
- Operating Temperature Range: -40°C to +125°C

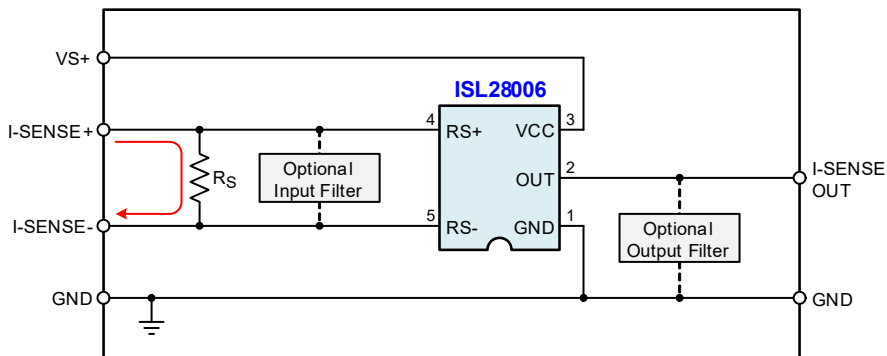

Figure 1. Block Diagram - Fixed Gain Version

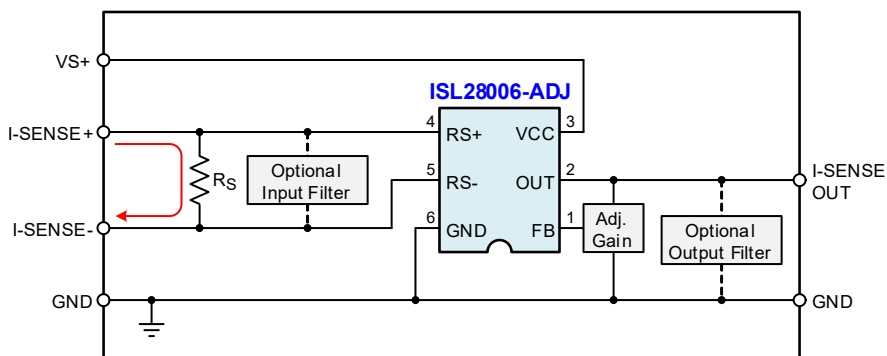

Figure 2. Block Diagram - Adjustable Gain Version

Contents

1. Functional Description	3
1.1 Optional Transient Protection	3
1.2 Power Supplies	3
2. Board Design	4
2.1 Schematic Diagrams	5
2.2 Bill of Materials	6
2.3 Board Layout	7
3. Ordering Information	7
4. Revision History	8

1. Functional Description

1.1 Optional Transient Protection

For applications where the load and the power source are permanently connected, transient protection is not required and only an external current sense resistor (R_3) is needed.

For applications where fast transients can generate voltage spikes that can overdrive the amplifier input and drive the output of the amplifier into the rails, a long overload recovery time will result. Common mode capacitors C_7 , C_9 and differential capacitor C_8 are used to filter the common mode and differential voltage spikes.

For switching applications or where fast transients are caused by hot plugging the source or load, external protection components may be needed. The external current limiting resistor (R_6) in [Figure 5](#) limits the peak current through the internal ESD diodes to <20mA. This condition can occur in applications that experience high levels of in-rush current causing high peak voltages that can damage the internal ESD diodes of the ISL28006. If the current limiting resistor is required, it needs to be placed on the RS- input (R_6). Placing it on the RS+ input side (R_7) results in a much larger error voltage because of the ISL28006 taking its supply current from the sense current in high-side applications.

For example:

Current limiting resistor R_6 with a value of 100Ω provides protection for a 2V transient with the maximum of 20mA flowing through the input while adding only an additional $13\mu\text{V}$ (worst case over-temperature) of V_{OS} as shown in [Equation 1](#). **Note:** Worst case over-temperature input bias current on the RS- input is 130nA.

$$\text{(EQ. 1)} \quad R_6 \times I_{RS-} = 100\Omega \times 130\text{nA} = 13\mu\text{V}$$

Current limiting resistor R_7 with value of 100Ω provides the same transient protection, but with an error voltage of $800\mu\text{V}$. **Note:** Worst case over-temperature input bias current on the RS+ input is $8\mu\text{A}$ as shown in [Equation 2](#).

$$\text{(EQ. 2)} \quad R_7 \times I_{RS+} = 100\Omega \times 8\mu\text{A} = 800\mu\text{V}$$

R_7 is a carry-over from our characterization board and was used to measure input bias current. The evaluation board is populated with a zero ohm resistor for R_7 .

1.2 Power Supplies

External power connections are made through the VS+ and Ground connections on the evaluation board. Capacitors C_2 and C_4 perform two duties, de-coupling the supplies and filtering of the power supply noise with R_{15} . Anti-reverse diodes D_1 and D_3 protect the circuit in the case of accidental polarity reversal of the supply. Resistor R_{12} is used to connect ground to the fixed gain parts.

2. Board Design

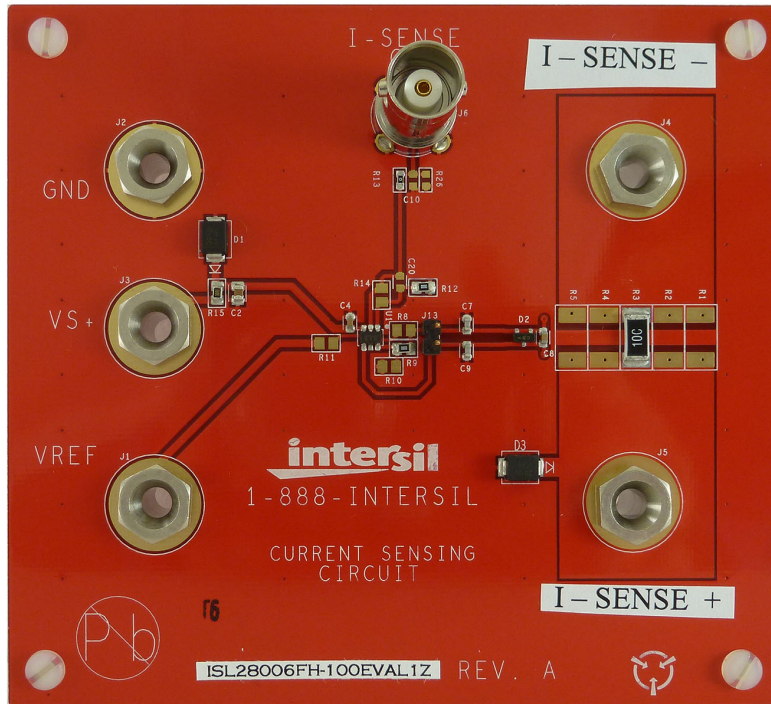

Figure 3. ISL28006FH-100EVAL1Z Evaluation Board (Top)

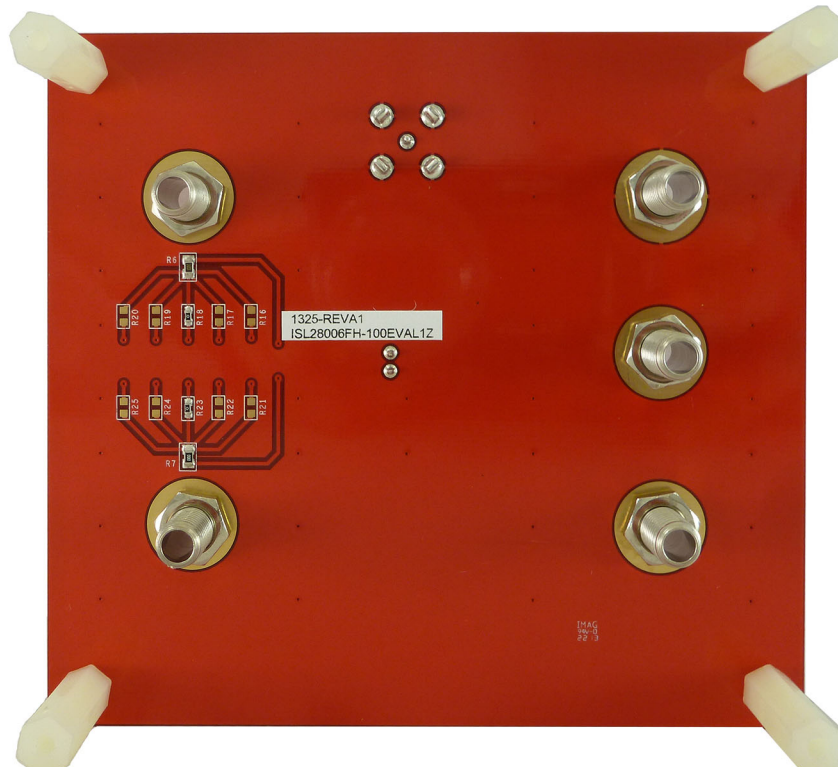

Figure 4. ISL28006FH-100EVAL1Z Evaluation Board (Bottom)

2.1 Schematic Diagrams

The ISL2800XEVAL1Z evaluation board is configured with either the ISL28006-100, ISL28006-50, ISL28006-20 or the ISL28006-ADJ device (adjustable gain via external resistors R₁₁ and R₁₄). **Note:** When using the adjustable part, V-REF (J₁) needs to be grounded. J₁₃ is provided to enable accurate voltage measurements across the sense resistor R₃.

Figure 5 shows the complete schematic for the ISL2800XEVAL1Z evaluation board.

Components shown in red in Figure 5 are optional transient protection and not required for clean environments. **Note:** The evaluation board comes equipped with the transient protection devices.

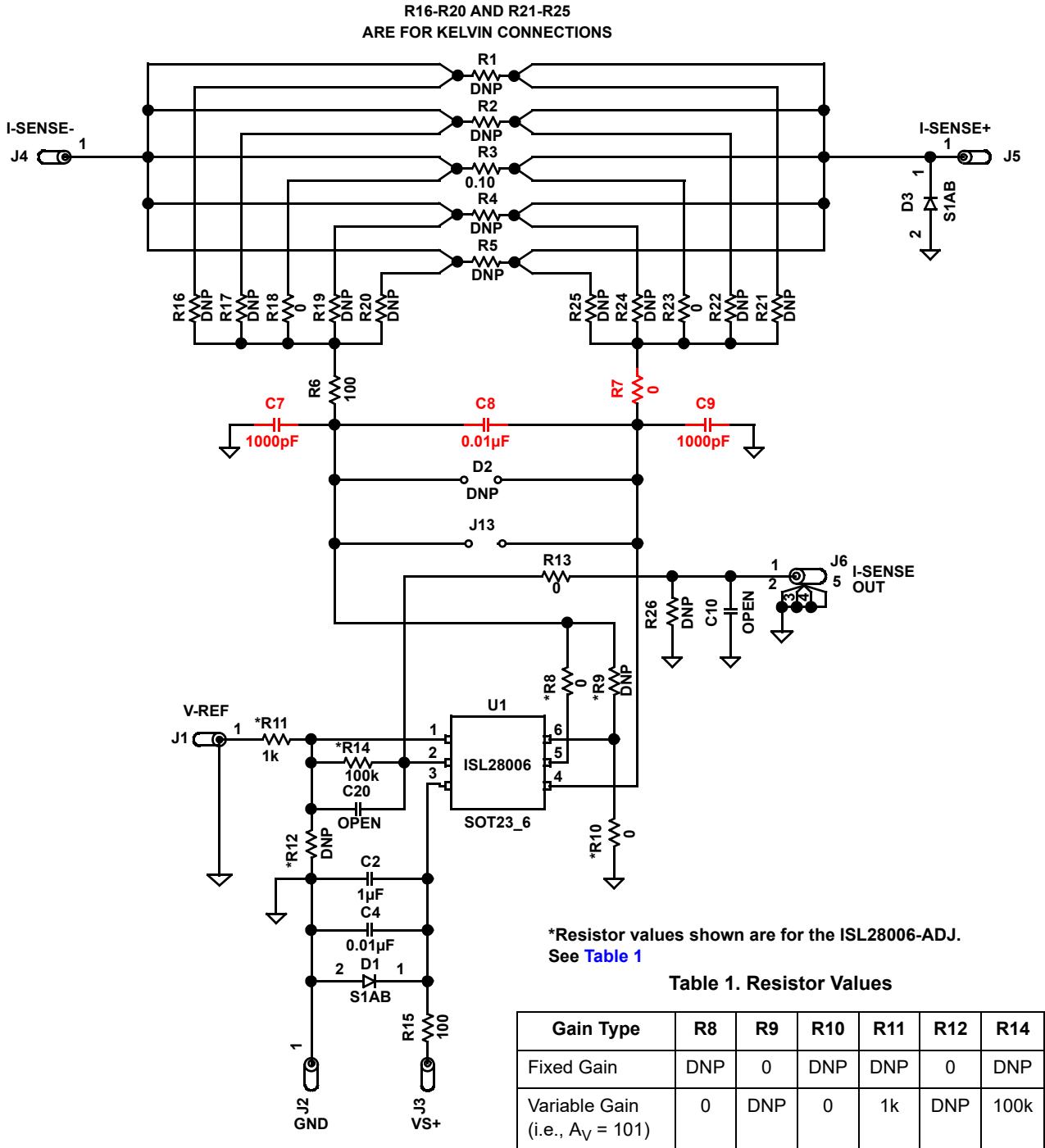

Figure 5. ISL2800XEVAL1Z Schematic Diagram

2.2 Bill of Materials

Reference Designator	Description	Comments
C2	CAP, SMD, 0805, 1 μ F, 50V, 20%, X7R, ROHS	Power Supply Decoupling and Input Filter
C4, C8	CAP, SMD, 0603, 0.01 μ F, 50V, 10%, X7R, ROHS	Power Supply Decoupling/Input Filter and Differential Current Sense Filter
C7, C9	CAP, SMD, 0603, 1000pF, 50V, 10%, X7R, ROHS	Common Mode Current Sense Filter
C10, C20	CAP, SMD, 0603, DNP-Place Holder, ROHS	User Selectable Capacitors - Not Populated
D1, D3	Diode-Rectifier, SMD, S1AB, 50V, ROHS	Reverse Power Protection
U1	ISL28006FH100Z-T7, SOT-23, ROHS	For ISL28006-100EVAL1Z board only
	ISL28006FH50Z-T7, SOT-23, ROHS	For ISL28006-50EVAL1Z board only
	ISL28006FH20Z-T7, SOT-23, ROHS	For ISL28006-20EVAL1Z board only
	ISL28006FHADJZ-T7-T7, SOT-23, ROHS	For ISL28006-ADJEVAL1Z board only
R16, R17, R19, R20, R21, R22, R24, R25	Resistor, SMD, 0603, MF, DNP-Place Holder	User Selectable Kelvin Connection - Not Populated
R26	Resistor, SMD, 0603, MF, DNP-Place Holder	User Selectable Output Load Resistor - Not Populated
R3	Resistor, SMD, 2512, 0.1 Ω , 1W, 1%, TF, ROHS	SENSE resistor
R1, R2, R4, R5	Resistor, SMD, 2512, DNP-Place Holder	User Selectable SENSE Resistors - Not Populated
R6, R7, R13, R18, R23	Resistor, SMD, 0603, 0 Ω , 1/10W, TF, ROHS	Zero Ohm User Selectable Resistors
R15	Resistor, SMD, 0603, 100 Ω , 1/10W, TF, ROHS	Current Limiting Resistors
R11	Resistor, SMD, 0603, 1k Ω , 1/10W, 1%, TF, ROHS (Variable Gain) RES, SMD, 0603, DNP-Place Holder (Fixed Gain)	Gain and Other User Selectable Resistors
R14	Resistor, SMD, 0603, 100k Ω , 1/10W, 1%, TF, ROHS (Variable Gain) RES, SMD, 0603, DNP-Place Holder (Fixed Gain)	Gain and Other User Selectable Resistors
R8, R10	Resistor, SMD, 0603, 0 Ω , 1/10W, 1%, TF, ROHS (Variable Gain) Resistor, SMD, 0603, DNP-Place Holder (Fixed Gain)	Gain and Other User Selectable Resistors
R9, R12	Resistor, SMD, 0603, DNP-Place Holder (Variable Gain) Resistor, SMD, 0603, 0 Ω , 1/10W, 1%, TF, ROHS (Fixed Gain)	Gain and Other User Selectable Resistors

2.3 Board Layout

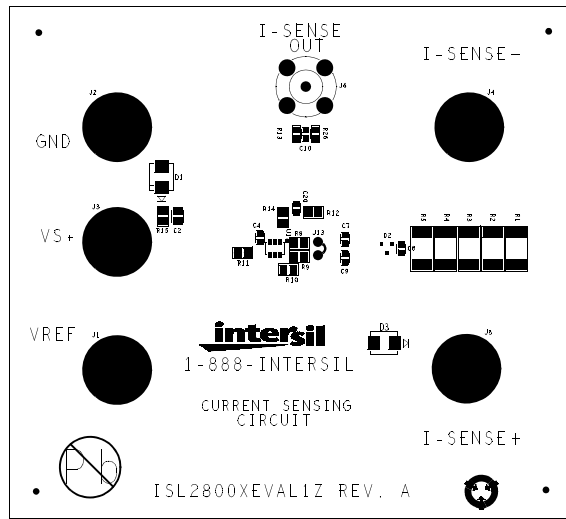

Figure 6. Silkscreen Top

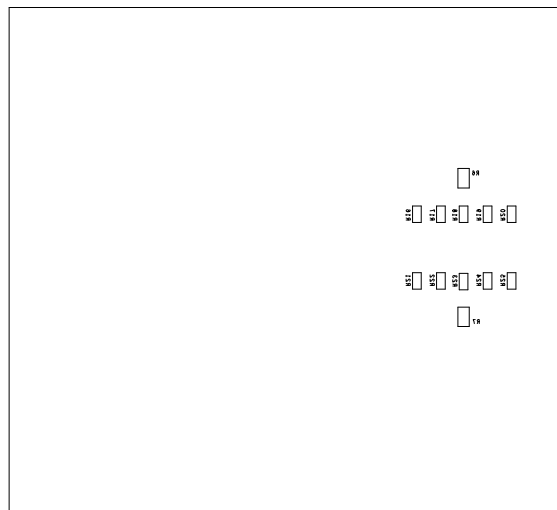

Figure 7. Silkscreen Bottom

3. Ordering Information

Part Number	Description
ISL28006-100EVAL1Z	ISL28006 100V/V fixed gain evaluation board
ISL28006-50EVAL1Z	ISL28006 50V/V fixed gain evaluation board
ISL28006-20EVAL1Z	ISL28006 20V/V fixed gain evaluation board
ISL28006-ADJEVAL1Z	ISL28006 adjustable gain evaluation board

4. Revision History

Revision	Date	Description
2.00	Feb 9, 2022	Applied new template. Updated Figures 1 and 2. Added Figures 3, 4, and 7. Added Ordering Information Tale.
1.00	Apr 12, 2010	Page 3 - Fig2 R11=1k, R14=100k Page 4 - Fig3 R11=1k, R14=100k Table1: variable gain = 101, R11 = 1k, R14 = 100k Page 5 - R11 TBD changed to 1k, R14 TBD changed to 100k.
0.00	Feb 18, 2010	Initial release