

ISL281x6EVAL1Z

Evaluation Board

AN1351  
Rev 0.00  
Aug 17, 2007

The ISL281x6EVAL1Z evaluation board is a design platform containing all the circuitry needed to characterize critical performance parameters of the ISL281x6 operational amplifiers, using a variety of user defined test circuits.

The ISL28136 and ISL28146 high-speed operational amplifiers feature low power consumption, while ISL28156 and ISL28166 operational amplifiers feature ultra-low power consumption. All op amps have rail-to-rail output drive capability and are designed to operate with a single lithium cell or two Ni\_Cd batteries.

**Reference Documents**

- ISL28136 Data Sheet, FN6153
- ISL28146 Data Sheet, FN6321
- ISL28156 Data Sheet, FN6154
- ISL28166 Data Sheet, FN6155

**Evaluation Board Key Features**

The ISL281x6EVAL1Z is designed to enable the IC to operate from a single supply, +2.4VDC to +5.5VDC or from split supplies, ±1.2VDC to ±2.75V. The board is configured for a single op amp connected for differential input with a closed loop gain of 10. It also contains a single external reference voltage (VREF) pin and provisions for a user-selectable voltage divider (filter are included).

**Power Supplies (Figure 1)**

External power connections are made through the V+, V- and Ground connections on the evaluation board. For single supply operation, the V- and Ground pins are tied together to the power supply negative terminal. For split supplies V+ and V- terminals connect to their respective power supply

terminals. De-coupling capacitors C<sub>1</sub> and C<sub>2</sub> connect to ground through R<sub>1</sub> and R<sub>21</sub> 0Ω resistors. Resistors R<sub>20</sub> and R<sub>24</sub> are 0Ω but can be changed by the user to provide additional power supply filtering, or to reduce the voltage rate-of-rise to less than ±1V/μs. Two additional capacitors, C<sub>3</sub> and C<sub>4</sub> are connected close to the part to filter out high frequency noise. Anti-reverse diodes D<sub>1</sub> and D<sub>2</sub> protect the circuit in the case of accidental polarity reversal.

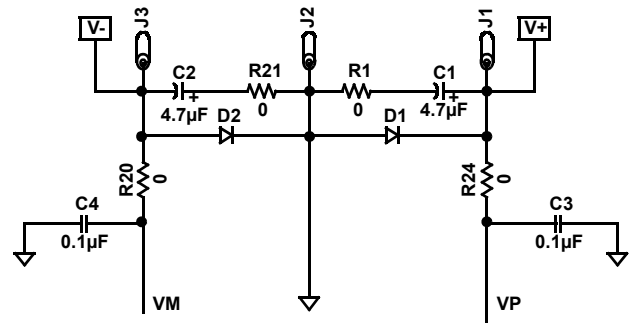

FIGURE 1. POWER SUPPLY CIRCUIT

**Amplifier Configuration (Figure 2)**

The schematic of the op amp with the components supplied is shown in Figure 2. The circuit implements a differential input amp with a closed loop gain of 10. The circuit can operate from a single supply or from dual supplies. The VREF pin can be connected to ground to establish a ground referenced input for split supply operation, or can be externally set to any reference level for single supply operation.

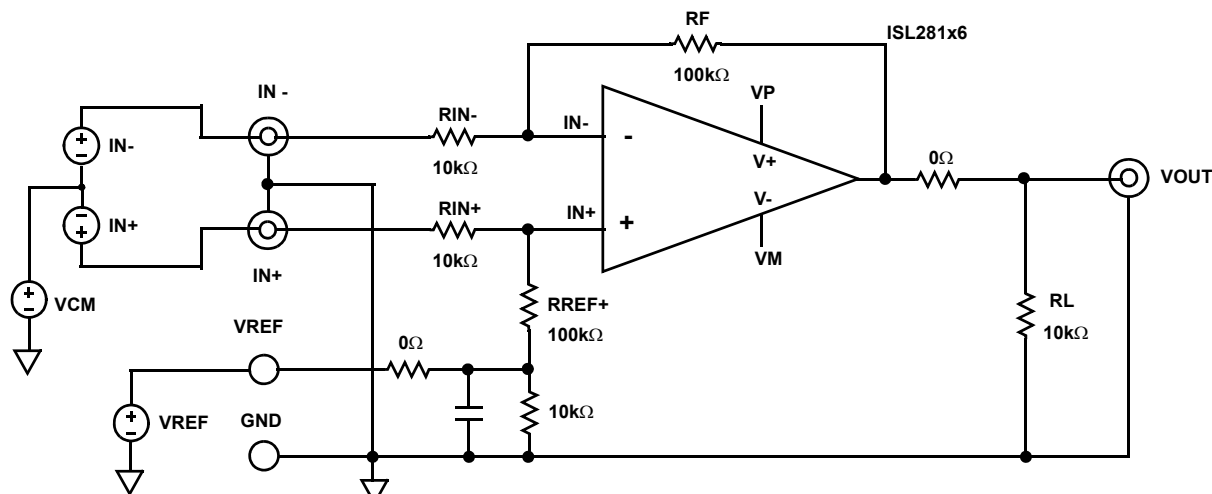

FIGURE 2. BASIC AMPLIFIER CONFIGURATION

**User-selectable Options (Figures 3 and 4)**

Component pads are included to enable a variety of user-selectable circuits to be added to the amplifier inputs, the VREF input, outputs and the amplifier feedback loops.

A voltage divider and filter option (Figure 3) can be added to establish a power supply-tracking common mode reference at the VREF input. The inverting and non-inverting inputs have additional resistor placements for adding input attenuation, or to establish input DC offsets through the VREF pin.

The output (Figure 4) has a 10kΩ load resistor to ground, and has additional resistor and capacitor placements for loading.

NOTE: Operational amplifiers are sensitive to output capacitance and may oscillate. In the event of oscillation, reduce output capacitance by using shorter cables, or add a resistor in series with the output.

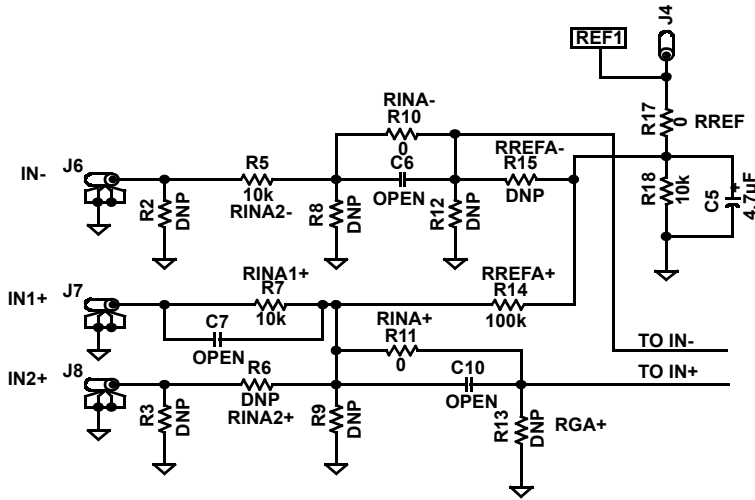

FIGURE 3. 1/2 INPUT STAGE

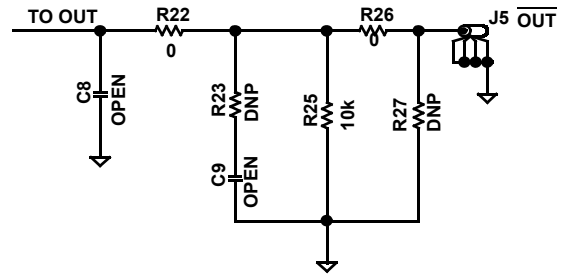
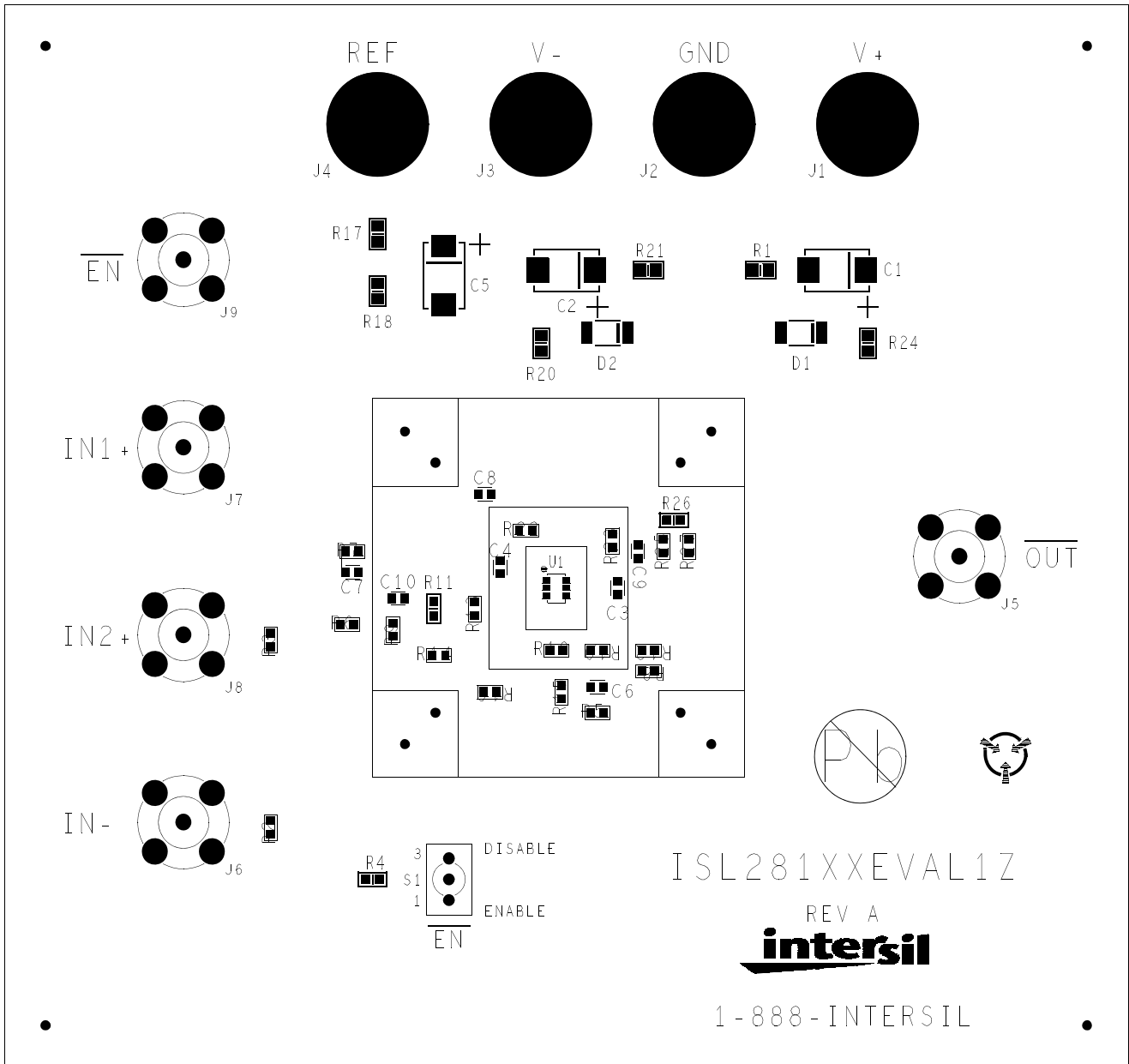

FIGURE 4. 1/2 OUTPUT STAGE

**ISL281x6EVAL1Z Components Parts List**

DEVICE NUMBER	DESCRIPTION	COMMENTS
C1, C2, C5	CAP-TANTALUM, SMD, D, 4.7μF, 50V, 10%, LOW ESR, ROHS	Power Supply Decoupling
C3,C4	CAP, SMD, 0603, 0.1μF, 25V, 10%, X7R, ROHS	Power Supply Decoupling
C6-C10	CAP, SMD, 0603, DNP-PLACE HOLDER, ROHS	User-selectable capacitors - not populated
D1, D2	DIODE-RECTIFIER, SMD, SOD-123, 2P, 40V, 0.5A, ROHS	Reverse Power Protection
U1 (ISL28136EVAL1Z)	ISL28136FHZ-T7, IC-RAIL-TO-RAIL OP AMP, SOT-23,ROHS	
U1 (ISL28146EVAL1Z)	ISL28146FHZ-T7, IC-RAIL-TO-RAIL OP AMP, SOT-23, ROHS	
U1 (ISL28156EVAL1Z)	ISL28156FHZ-T7, IC-RAIL-TO-RAIL OP AMP, SOT-23, ROHS	
U1 (ISL28166EVAL1Z)	ISL28166FHZ-T7, IC-RAIL-TO-RAIL OP AMP, SOT-23, ROHS	
R2, R3, R6, R8, R9, R12, R13, R15, R16, R23, R25, R27	RESISTOR, SMD, 0603, 0.1%, MF, DNP-PLACE HOLDER	User-selectable resistors - not populated
R1, R10, R11, R17, R20, R21, R24, R26, R22	RES, SMD, 0603, 0Ω, 1/10W, TF, ROHS	0Ω user-selectable resistors
R4, R5, R7, R18	RES, SMD, 0603, 10k, 1/10W, 1%, TF, ROHS	Gain and other user selectable resistors
R14, R19	RES, SMD, 0603, 100k, 1/10W, 1%, TF, ROHS	Gain resistors

**ISL281x6EVAL1Z Top View**



ISL281x6EVAL1Z Schematic Diagram

