

ISL2819xEVAL1Z

Evaluation Board

AN1348
Rev 1.00
May 19, 2011

The ISL2819xEVAL1Z evaluation board is a design platform containing all the circuitry needed to characterize critical performance parameters of the ISL28190 and ISL28191 single operational amplifiers, using a variety of user-defined test circuits.

The ISL28190 and ISL28191 amplifiers feature ultra-low noise, ultra-low distortion, and rail-to-rail output drive capability. They are designed to operate with single and dual supplies from +5.5VDC (± 2.75 VDC) down to +3VDC (± 1.5 VDC).

Reference Documents

- [ISL28190 Datasheet](#)
- [ISL28191 Datasheet](#)

Key Features

The ISL2819xEVAL1Z is designed to enable the IC to operate from a single supply (+3VDC to +5.5VDC) or from split supplies (± 1.5 VDC to ± 2.75 VDC). The board is configured for a single op amp connected for differential input with a closed loop gain of 10. A single external reference voltage (VREF) pin is provided, as well as a user-selectable voltage divider (filter included).

Power Supplies (Figure 1)

External power connections are made through the V+, V- and ground connections on the evaluation board. For single-supply operation, the V- and ground pins are tied together to the power supply negative terminal. For split supplies, the V+ and V- terminals connect to their respective power supply terminals. De-coupling capacitors C2 and C4 are connected close to the power supply terminals. To filter out high-frequency noise, four additional capacitors (C1, C5, C7 and C8) are connected close to the part. Anti-reverse diodes, D1 and D2, protect the circuit in case of accidental polarity reversal.

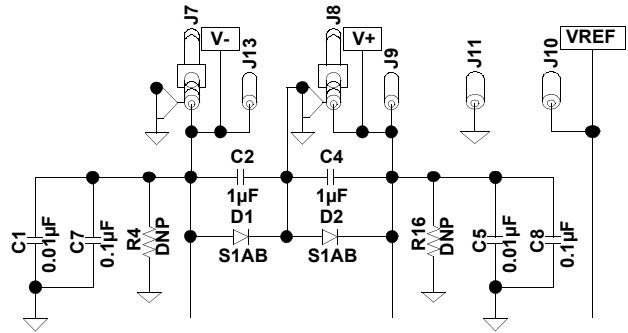

FIGURE 1. POWER SUPPLY CIRCUIT

D1 and D2, protect the circuit in case of accidental polarity reversal.

Amplifier Configuration (Figure 2)

The schematic of the op-amp with the components supplied is shown in Figure 2. The circuit implements a differential input amp with a closed loop gain of 10. The circuit can operate from a single +3VDC to +5.5VDC supply, or from dual supplies from ± 1.5 VDC to ± 2.75 VDC. The VREF pin can be connected to ground to establish a ground-referenced input for split-supply operation, or it can be externally set to any reference level for single-supply operation.

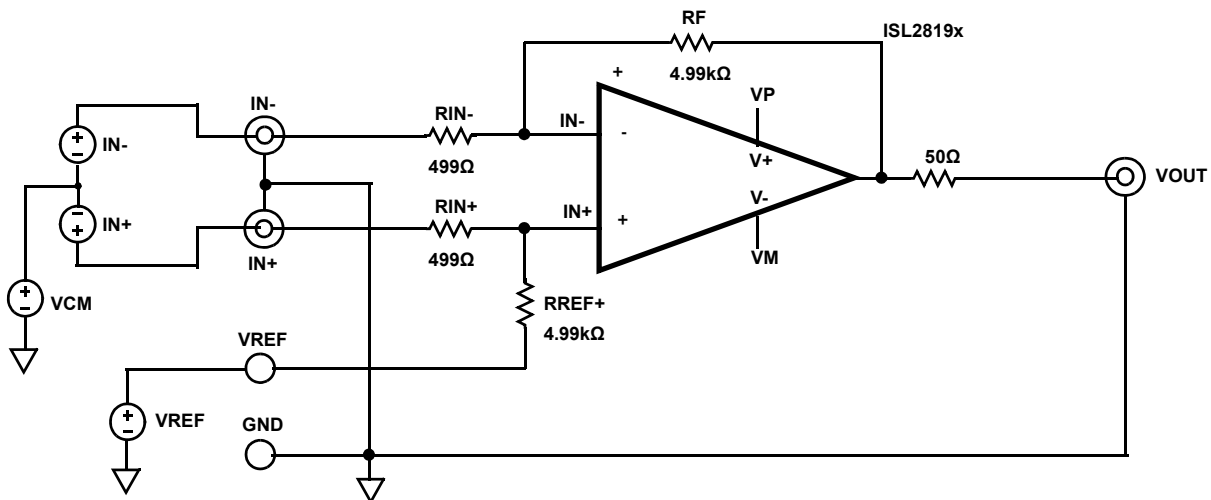

FIGURE 2. BASIC AMPLIFIER CONFIGURATION

User-selectable Options (Figures 3 and 4)

Component pads are included to enable a variety of user-selectable circuits to be added to the amplifier inputs, the VREF input, the outputs, and the amplifier feedback loops.

A voltage divider and filter option (Figure 3) can be added to establish a power-supply-tracking common mode reference at

the VREF input. The inverting and non-inverting inputs have additional resistor placements for adding input attenuation, or to establish input DC offsets through the VREF pin.

The output (Figure 4) has a series 50Ω back-termination resistor to drive 50Ω cables, and additional resistor and capacitor placements for loading.

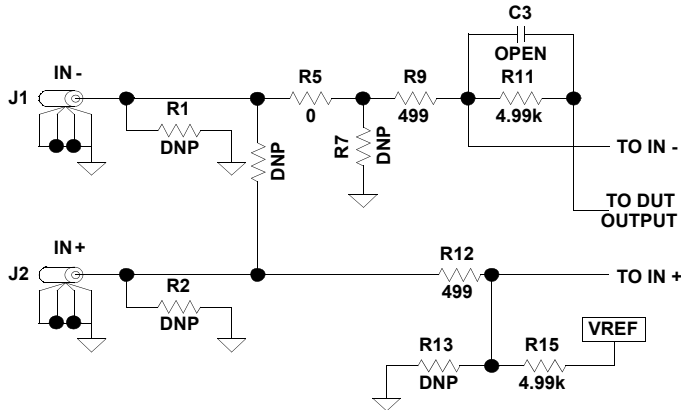

FIGURE 3. INPUT STAGE

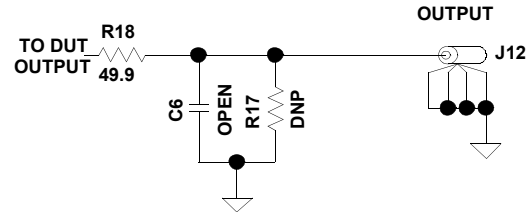
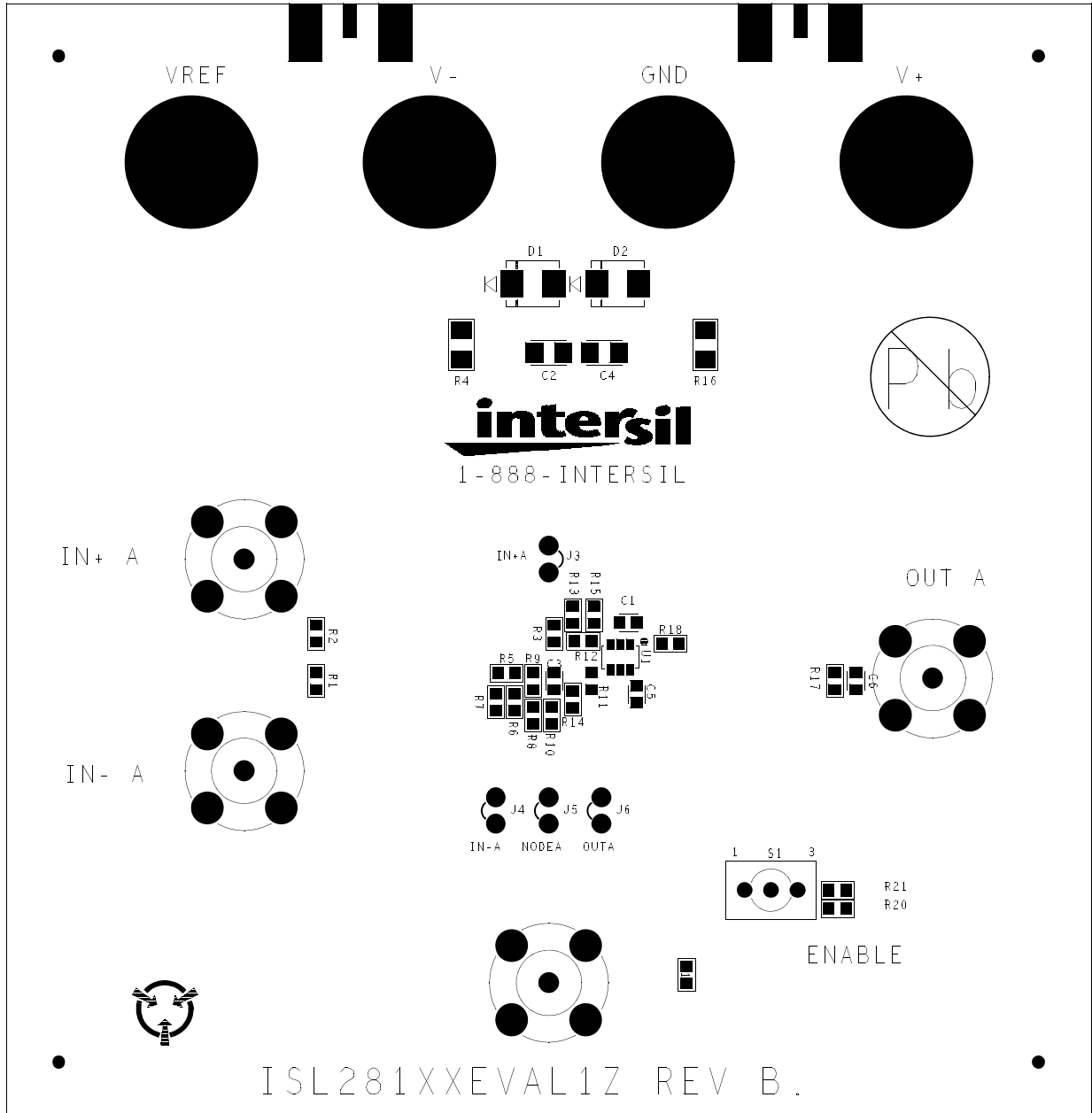

FIGURE 4. OUTPUT STAGE

ISL2819xEVAL1Z Components Parts List

DEVICE NUMBER	DESCRIPTION	COMMENTS
C2, C4	CAP, SMD, 1206, 1μF, 100V, 10%, X7R, ROHS	Power supply decoupling
C1, C5	CAP, SMD, 0603, 0.01μF, 50V, 10%, X7R, ROHS	Power supply decoupling
C7, C8	CAP, SMD, 0603, 0.1μF, 50V, 10%, X7R, ROHS	Power supply decoupling
C3, C6	CAP, SMD, 0603, DNP-PLACE HOLDER, ROHS	User-selectable capacitors; not populated
D1, D2	DIODE-RECTIFIER, SMD, 4.5X3.9mm, 50V, 1A, ROHS	Reverse power protection
U1 (ISL28190EVAL1Z)	ISL28190FHZ-T7, IC-RAIL-TO-RAIL OP AMP, SOT-23, ROHS	
U1 (ISL28191EVAL1Z)	ISL28191FHZ-T7, IC-RAIL-TO-RAIL OP AMP, SOT-23, ROHS	
R1-R4, R6-R8, R10, R13, R14, R16, R17, R20	RESISTOR, SMD, 0603, 0.1%, MF, DNP-PLACEHOLDER	User-selectable resistors; not populated
R5, R21	RES, SMD, 0603, 0Ω, 1/10W, TF, ROHS	0Ω user-selectable resistors
R18	RES, SMD, 0603, 49.9Ω, 1/10W, 1%, TF, ROHS	User-selectable output resistors
R9, R12	RES, SMD, 0603, 499Ω, 1/10W, 1%, TF, ROHS	Gain resistors
R11, R15	RES, SMD, 0603, 4.99k, 1/10W, 1%, TF, ROHS	Gain resistors
R19	RES, SMD, 0603, 10k, 1/10W, 1%, TF, ROHS	User-selectable resistors

ISL2819xEVAL1Z Top View



ISL2819xEVAL1Z Schematic Diagram

