

ISL28208SOICEVAL2Z

Evaluation Board

AN1658  
Rev 0.00  
Jul 26, 2011

Introduction

The ISL28208SOICEVAL2Z evaluation board is designed to evaluate the performance of the ISL28208 dual Operational Amplifier. The ISL28208 is a dual low power precision amplifier that features a common mode input voltage range extending to 0.5V below the V- rail, a rail-to-rail differential input voltage range for use as a comparator, and rail-to-rail output voltage swing, which makes it ideal for single supply applications where input operation at ground is important. With a wide operating range from 3V to 40V, in combination with its precision, low power, and small footprint, ISL28208 provides the user with outstanding value and flexibility relative to similar competitive parts.

Reference Documents

- ISL28208 Data Sheet, [FN6935](#)

Evaluation Board Key Features

- Single Supply Operation: +9V to +40V
- Dual Supply Operation: ±4.5V to ±20V
- Singled-Ended or Differential Input Operation
- External VREF input
- Banana Jack Connectors for Power Supply and VREF Inputs
- BNC Connectors for Op Amp Input and Output Terminals
- Convenient PCB Pads for Op Amp Input/Output Impedance Loading

Power Supplies (Figure 1)

External power connections are made through the V+, V-, VREF, and GND connections on the evaluation board. The circuit can operate from a single supply or from dual supplies. For single supply operation, the V- and GND pins are tied together to the negative or ground reference of the power supply. For split supplies, V+ and V- terminals connect to their respective supply terminals. De-coupling capacitors C2 and C4 provide low-frequency power-supply filtering, while additional capacitors, C3 and C5, which are connected close to the part, filter out high frequency noise. Anti-reverse diode D1 (optional) protects the circuit in the momentary case of accidentally reversing the power supplies to the evaluation board. The VREF pin can be connected to ground to establish a ground referenced input for split supply operation, or can be externally set to any reference level for single supply operation.

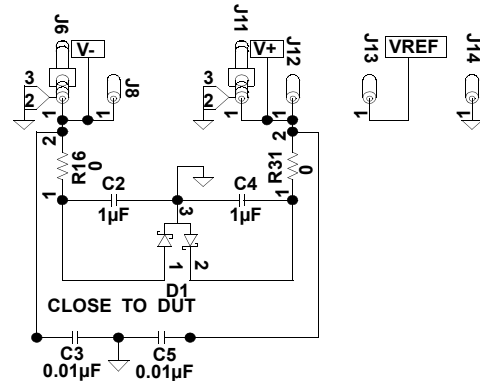

FIGURE 1. POWER SUPPLY CIRCUIT

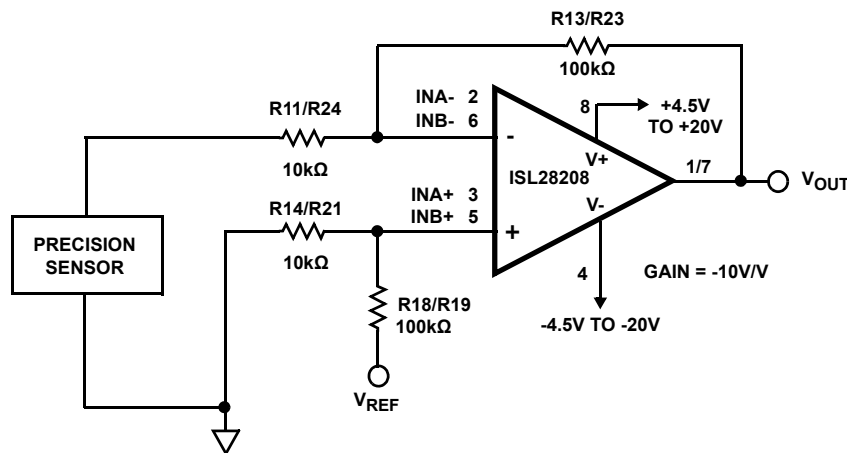

FIGURE 2. PRECISION AMPLIFIER WITH G = -10V/V

### Amplifier Configuration (Figure 3)

The schematic of the op amp input stage with the components supplied is shown in Figure 3, with a closed loop gain of 10V/V. The differential amplifier gain is expressed in Equation 1:

$$V_{OUT} = (V_{IN+} - V_{IN-}) \cdot (R_F/R_{IN}) + V_{REF} \tag{EQ. 1}$$

For single-ended input with an inverting gain  $G = -10V/V$ , the IN+ input is grounded and the signal is supplied to the IN- input. VREF can be connected to a reference voltage between the V+ and V- supply rails. For non-inverting operation with  $G = 11V/V$ , the IN- input is grounded and the signal is supplied to the IN+ input. The non-inverting gain is strongly dependent on any resistance from IN- to GND. For good gain accuracy, a 0Ω resistor should be installed on the empty R5 pad.

### User-selectable Options (Figures 3 and 4)

Component pads are included to enable a variety of user-selectable circuits to be added to the amplifier inputs, the VREF input, outputs and the amplifier feedback loops.

A voltage divider (Figure 3, R18 and R15) can be added to establish a power supply-tracking common mode reference using the VREF input. The inverting and non-inverting inputs have additional resistor placements for adding input attenuation, or to establish input DC offsets through the VREF pin.

The output (Figure 4) also has additional resistor and capacitor placements for filtering and loading.

NOTE: Operational amplifiers are sensitive to output capacitance and may oscillate. In the event of oscillation, reduce output capacitance by using shorter cables, or add a resistor in series with the output.

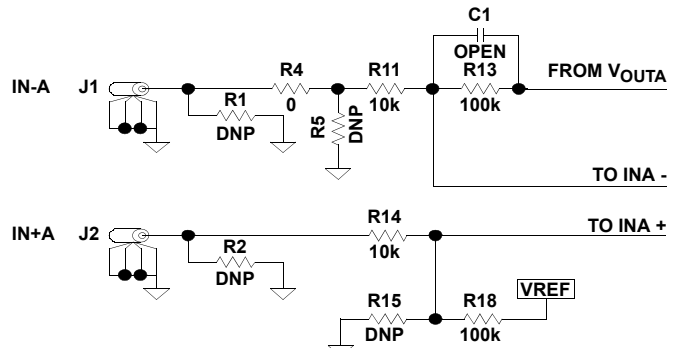

FIGURE 3. INPUT STAGE

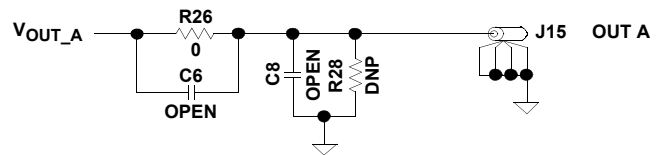
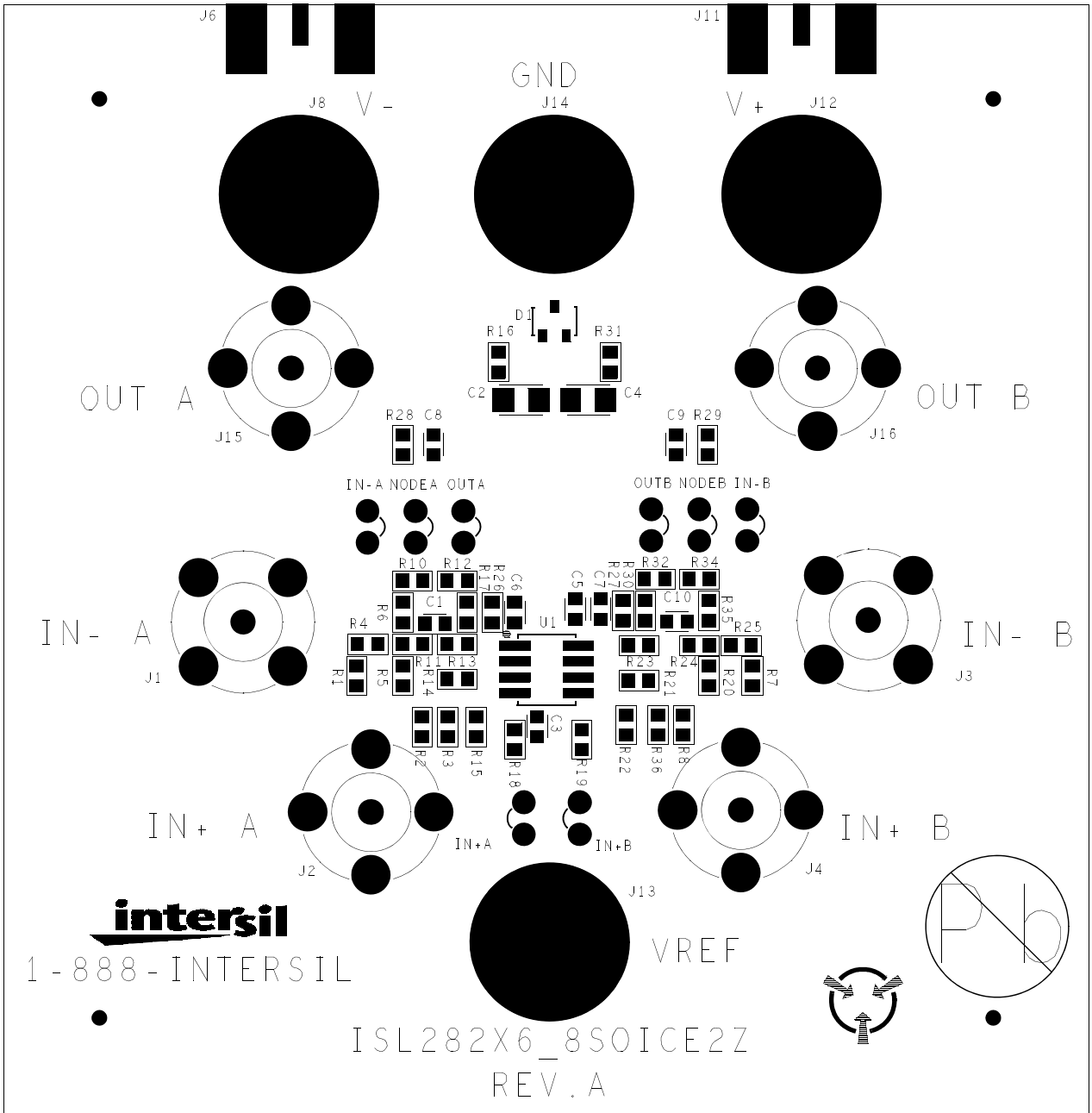

FIGURE 4. OUTPUT STAGE

TABLE 1. ISL28208SOICEVAL2Z COMPONENTS PARTS LIST

DEVICE #	DESCRIPTION	COMMENTS
C2, C4	CAP, SMD, 1206, 1μF, 50V, 10%, X7R, ROHS	Power Supply Decoupling
C3, C5	CAP, SMD, 0603, 0.01μF, 50V, 10%, X7R, ROHS	Power Supply Decoupling
C1, C6, C7, C8, C9, C10	CAP, SMD, 0603, DNP-PLACE HOLDER, ROHS	User selectable capacitors - not populated
D1	40V DUAL SERIES SCHOTTKY BARRIER DIODE	Reverse Power Protection
R11, R14, R21, R24	RESISTOR, SMD, 0603, 10kΩ, 1%, 1/16W, ROHS	Gain Setting Resistor
R13, R23	RESISTOR, SMD, 0603, 100kΩ, 1%, 1/16W, ROHS	Gain Setting Feedback Resistor
R1-R3, R5-R8, R10, R12, R15, R17, R20, R22, R28-R30, R32, R34-R36	RESISTOR, SMD, 0603, DNP-PLACE HOLDER, ROHS	User selectable resistors - not populated
U1 (ISL28208FBZ)	ISL28208FBZ, IC PRECISION LOW NOSIE JFET OP AMP, SOIC, ROHS	

# ISL28208SOICEVAL2Z Top View



# ISL28208SOICEVAL2Z Schematic Diagram

