

ISL282X8MSOPEVAL1Z, ISL282X8SOICEVAL1Z

Evaluation Board

AN1419
Rev 0.00
Aug 28, 2008

Introduction

The ISL282X8MSOPEVAL1Z and ISL282X8SOICEVAL1Z evaluation board are design platforms containing all the circuitry needed to characterize critical performance parameters of the ISL282X8 operational amplifiers in both MSOP-8 and SOIC-8 packages, using a variety of user defined test circuits.

The ISL28238 and ISL28248 high-speed operational amplifiers feature low power consumption, while ISL28258 and ISL28268 operational amplifiers feature ultra-low power consumption. All op amps have rail-to-rail output drive capability and are designed to operate with a single lithium cell or two Ni_Cd batteries.

Reference Documents

- ISL28238 Data Sheet, FN6336
- ISL28248 Data Sheet, FN6337
- ISL28258 Data Sheet, FN6377
- ISL28268 Data Sheet, FN6378

Evaluation Board Key Features

The ISL282xEVAL1Z is designed to enable the IC to operate from a single supply, +2.4VDC to +5.5VDC or from split supplies, ±1.2VDC to ±2.75V. The board is configured for a dual op amp connected for differential input with a closed loop gain of 10. A single external reference voltage (VREF) pin and provisions for a user-selectable voltage divider-filter are included.

Power Supplies

External power connections are made through the +V, -V, VREF and Ground connections on the evaluation board.

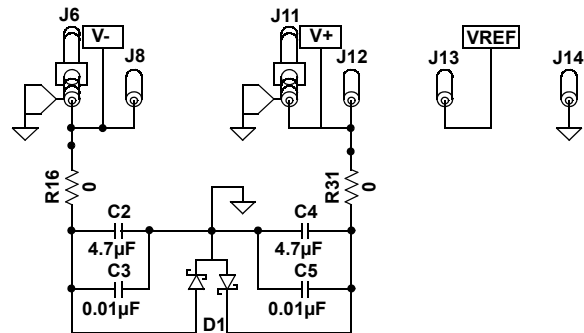

FIGURE 1. POWER SUPPLY CIRCUIT

User-selectable SMA edge connectors are also provided for +V and -V. For single supply operation, the -V and Ground pins are tied together to the power supply negative terminal. For split supplies +V and -V terminals connect to their respective power supply terminals. De-coupling capacitors C2 and C4 connect to their respective supplies through R16 and R31 0Ω resistors. These resistors are 0Ω but can be changed by the user to provide additional power supply filtering, or to reduce the voltage rate-of-rise to less than ±1V/μS. Two additional capacitors, C3 and C5 are connected close to the part to filter out high frequency noise. Anti-reverse diode D1 protects the circuit in the case of accidental polarity reversal (see Figure 1).

Amplifier Configuration

The schematic of 1/2 of the op amp with the components supplied is shown in Figure 2. The circuit implements a differential input amp with a closed loop gain of 10. The circuit can operate from a single supply or from dual supplies. The VREF pin must be connected to ground to

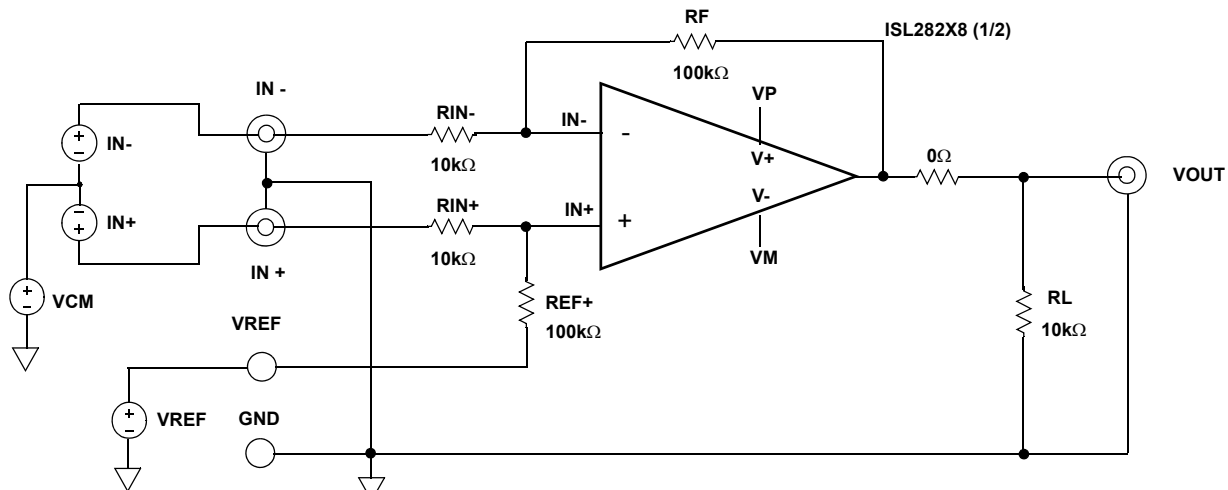

FIGURE 2. BASIC AMPLIFIER CONFIGURATION

establish a ground referenced input for dual supply operation, or can be externally set to any reference level for single supply operation. VREF should not be left floating.

User-selectable Options

Component pads are included to enable a variety of user-selectable circuits to be added to the amplifier VREF, inputs, outputs, and the amplifier feedback loops. The Inputs (see Figure 3) have additional resistor and capacitor, and

jumper placements for loading and/or measurement of frequency sensitive parameters.

The outputs (see Figure 4) have a 10kΩ load resistor to ground and have additional resistor and capacitor placements for loading.

NOTE: Operational amplifiers are sensitive to output capacitance and may oscillate. In the event of oscillation, reduce output capacitance by using shorter cables, or add a resistor in series with the output.

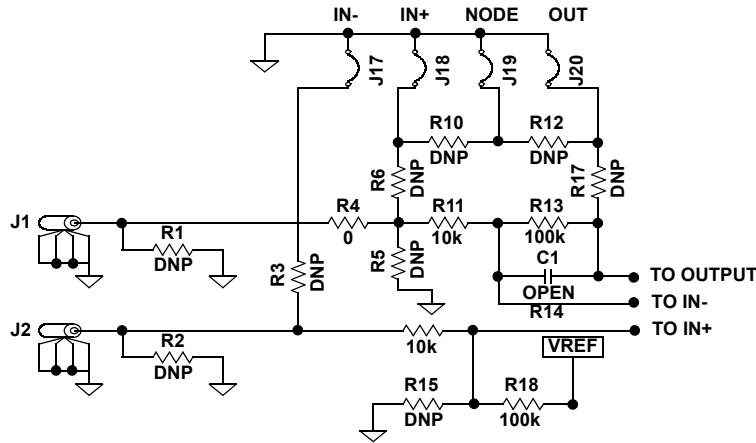

FIGURE 3. INPUT STAGE

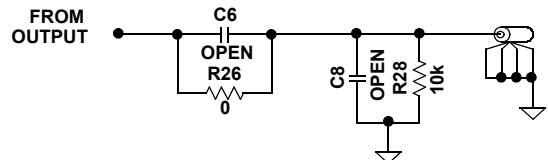
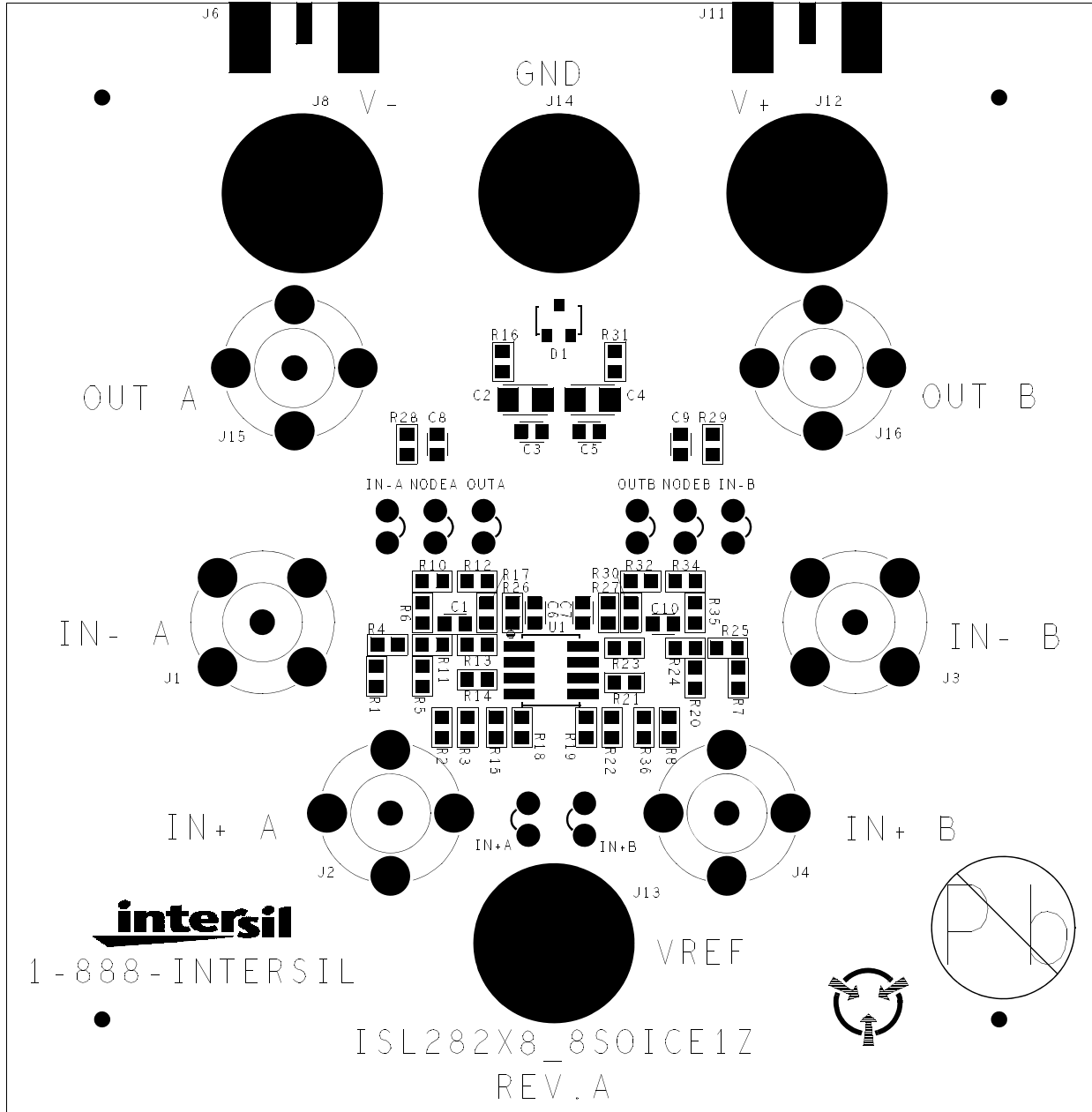

FIGURE 4. OUTPUT STAGE

TABLE 1. ISL282X8EVAL1Z COMPONENTS PARTS LIST

DEVICE #	DESCRIPTION	COMMENTS
C2, C4	CAP-TANTALUM, SMD, D, 4.7μF, 50V, 10% LOW ESR, ROHS	Power Supply Decoupling
C3, C5	CAP, SMD, 0603, 1μF, 25V, 10%, X7R, ROHS	Power Supply Decoupling
C1, C6 to C10	CAP, SMD, 0603, DNP-Place Holder, ROHS	User-Selectable Capacitors - Not Populated
D1	Diode-Schottky Barrier, SMD, SOT-23, 3P, 40V, ROHS	Reverse Power Protection
U1 (ISL28238FUZ)	IC-5 MHz RRIO OP AMP, 8P, MSOP, ROHS	
U1 (ISL28238FBZ)	IC-5 MHz RRIO OP AMP, 8P, SOIC, ROHS	
U1 (ISL28248FUZ)	IC-5 MHz RRIO OP AMP, 8P, MSOP, ROHS	
U1 (ISL28248FBZ)	IC-5 MHz RRIO OP AMP, 8P, SOIC, ROHS	
U1 (ISL28258FUZ)	IC-39μA RRIO OP AMP, 8P, MSOP, ROHS	
U1 (ISL28258FBZ)	IC-39μA RRIO OP AMP, 8P, SOIC, ROHS	
U1 (ISL28268FUZ)	IC-39μA RRIO OP AMP, 8P, MSOP, ROHS	
U1 (ISL28268FBZ)	IC-39μA RRIO OP AMP, 8P, SOIC, ROHS	
R30, R32, R34 to R36	RES, SMD, 0603, 0.1%, MF, DNP-PLACE HOLDER	User-Selectable Resistors - Not Populated
R4, R16, R25 to R27, R31	RES, SMD, 0603, 0Ω, 1/10W, TF, ROHS	0Ω User-Selectable Resistors
R11, R14, R21, R24, R28, R29	RES, SMD, 0603, 10k, 1/10W, 1%, TF, ROHS	Gain and Other User-Selectable Resistors
R13, R18, R19, R23	RES, SMD, 0603, 100k, 1/10W, 1%, TF, ROHS	Gain Resistors

ISL282X8EVAL1Z Top View (SOIC Shown)



ISL282X8EVAL1Z Schematic Diagram

