

ISL28414TSSOPEVAL1Z

Evaluation Board

AN1547
Rev 0.00
Mar 4, 2010

Introduction

The ISL28414TSSOPEVAL1Z evaluation board is a design platform containing all the circuitry needed to characterize critical performance parameters of the ISL28414 quad, CMOS rail-to-rail input and output operational amplifiers, using a variety of user defined test circuits.

The ISL28414 amplifiers feature low input bias current, low power consumption, and rail-to-rail input and output drive capability. They are designed to operate with single and dual supplies from +5V_{DC} (±2.5V_{DC}) down to +2.4V_{DC} (±1.2V_{DC}).

Reference Documents

- ISL28414 Data Sheet, FN6800

Evaluation Board Key Features

The ISL28414TSSOPEVAL1Z is designed to enable the IC to operate from a single supply (+1.8V_{DC} to +5.5V_{DC}), or from split supplies (±0.9V_{DC} to ±2.75V). The board is configured for 4 independent op amps connected for differential input with a closed loop gain of 10. A single external reference voltage (V_{REF}) pin and provisions for a user-selectable voltage divider - filter is included. Additional user selectable component placements are included to enable the user to configure and test a large variety of amplifier circuits.

Power Supplies (Figure 1)

External power connections are made through the +V, -V and Ground connections on the evaluation board. For single supply operation, the -V and Ground pins are tied

together to the power supply negative terminal. For split supplies +V and -V terminals connect to their respective power supply terminals. De-coupling capacitors C₁, C₂, connect to ground through R₁, R₄₄, zero ohm resistors. Resistors R₃₇ and R₄₈ are 0Ω but can be changed by the user to provide additional power supply filtering. Anti-reverse diodes D₁ and D₂ protect the circuit in the case of accidental polarity reversal.

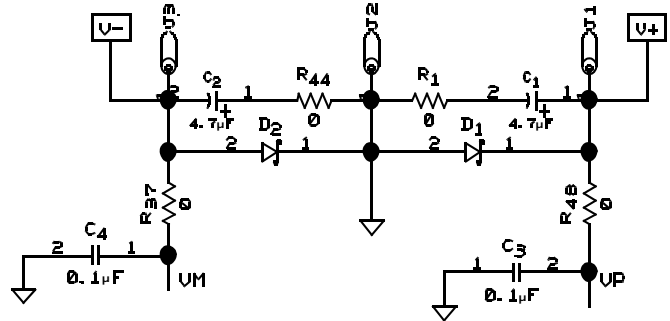

FIGURE 1. POWER SUPPLY CIRCUIT

Amplifier Configuration (Figure 2)

The schematic of each of the 4 op amps with the components supplied is shown in Figure 2. The circuit implements a differential input amp with a closed loop gain of 10. The circuit can operate from a single (+1.8V_{DC} to +5.5V_{DC} supply, or from dual supplies from ±0.9V_{DC} to ±2.75V. The V_{REF} pin can be connected to ground to establish a ground referenced input for split supply operation, or can be externally set to any reference level for single supply operation.

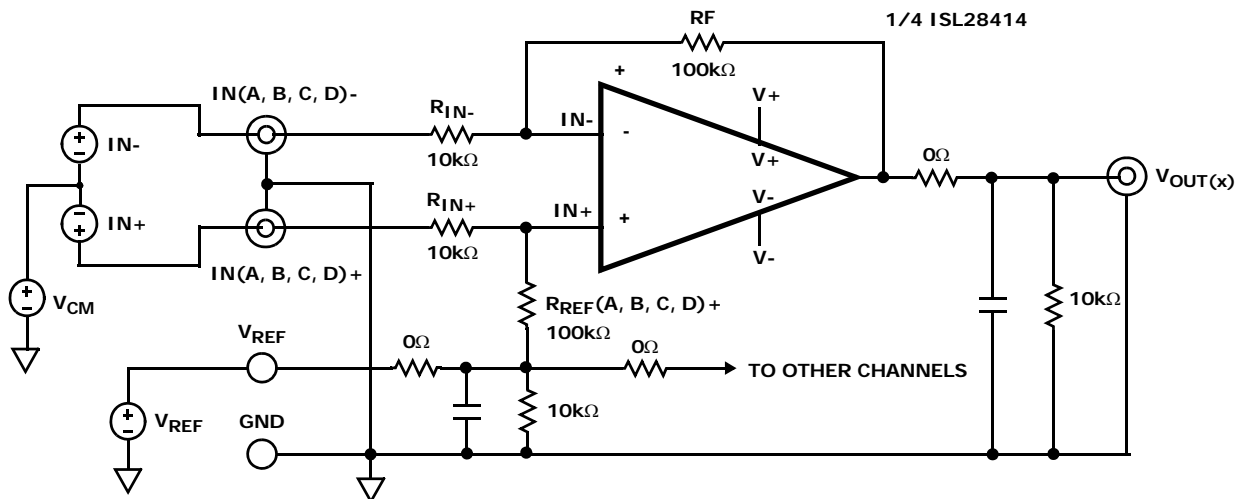

FIGURE 2. BASIC AMPLIFIER CONFIGURATION

User-Selectable Options (Figure 3)

Component pads are included to enable a variety of user-selectable circuits to be added to the amplifier inputs, the V_{REF} input, and the amplifier feedback loops. A voltage divider and filter option can be added to establish a power supply-tracking common mode reference at the V_{REF} input. The inverting and non-inverting inputs have additional resistor placements for adding input attenuation, or to establish input DC offsets through the V_{REF} pin.

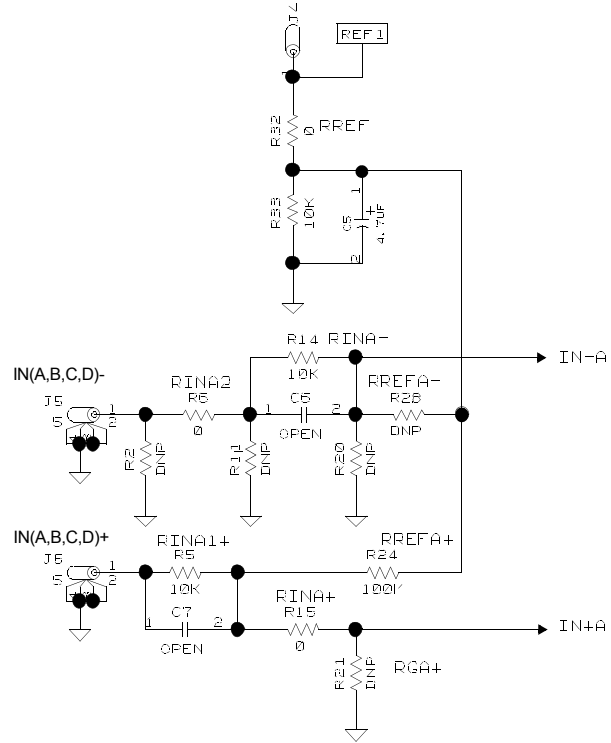
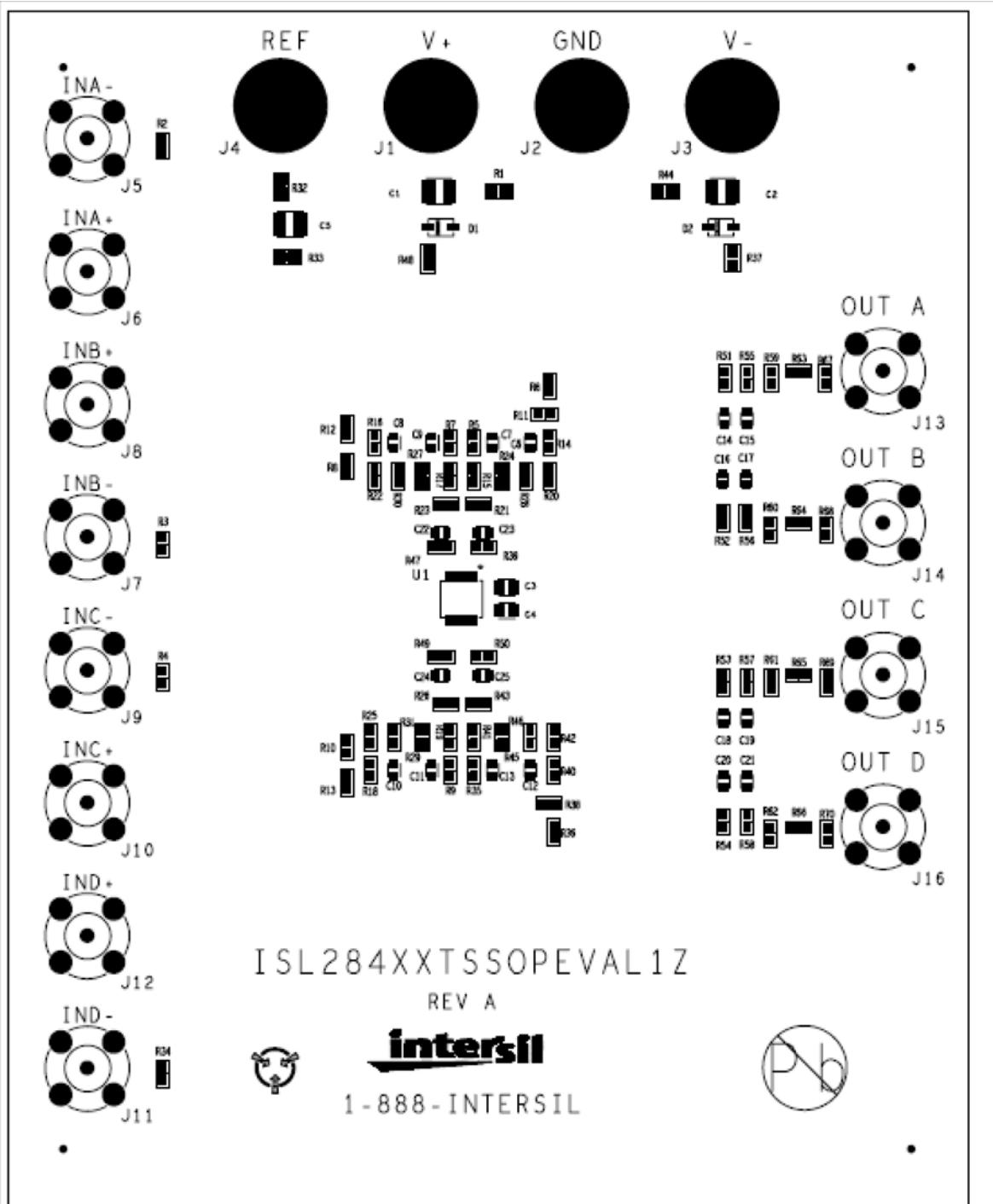

FIGURE 3. COMPONENT-SELECTABLE OPTIONS

ISL28414TSSOPEVAL1Z Components Parts List

DEVICE #	DESCRIPTION	COMMENTS
C1, C2, C5	CAP-TANTALUM, SMD, D, 4.7μF, 50V, 10%. LOW ESR, ROHS	Power Supply Decoupling
C3, C4	CAP, SMD, 0603, 0.1μF, 25V, 10%, X7R, ROHS	Power Supply Decoupling
C6, C7, C8, C9, C10, C11, C12, C13, C14, C15, C16, C17, C18, C19, C20, C21, C22, C23, C24, C25	CAP, SMD, 0603, DNP-PLACE HOLDER, ROHS	User selectable capacitors - not populated
D1, D2	DIODE-RECTIFIER, SMD, SOD-123, 2P, 40V, 0.5A, ROHS	Reverse Power Protection
U1	ISL28414FVZ, IC-RRIO OP AMP, 16P, TSSOP, ROHS	
R2, R3, R4, R11, R12, R13, R20, R21, R22, R23, R25, R26, R28, R30, R31, R34, R38, R42, R43, R46, R55, R56, R57, R58, R59, R60, R61, R62	RESISTOR, SMD, 0603, 0.1%, MF, DNP-PLACE HOLDER	User selectable resistors - not populated
R6, R8, R10, R15, R17, R19, R36, R41, R51, R52, R53, R54, R63, R64, R65, R66	RES, SMD, 0603, 0Ω, 1/16W, TF, ROHS	Zero ohm user selectable resistors
R5, R7, R9, R14, R16, R18, R33, R35, R40, R67, R68, R69, R70	RES, SMD, 0603, 10k, 1/10W, 1%, TF, ROHS	RG gain resistors
R24, R27, R29, R39, R45, R47, R49, R50	RES, SMD, 0603, 100k, 1/10W, 1%, TF, ROHS	RF gain resistors
R1, R32, R37, R44, R48	RES, SMD, 0805, 0Ω, 1/8W, TF, ROHS	Zero ohm user selectable resistors

ISL28414TSSOPEVAL1Z Top View



ISL28414TSSOPEVAL1Z Schematic Diagram

