

## ISL45042EVAL1Z

User's Manual

AN1188  
Rev 2.00  
Oct 4, 2006

### Description

The ISL45042EVAL1Z is a RoHS compliant evaluation board for the ISL45042, LCD Module Calibrator. For detailed information on the ISL45042, reference the ISL45042 data sheet (FN6072). Additionally, for detailed information on the dual low noise Amplifier, please refer to the EL5220 data sheet (FN7186).

The ISL45042EVAL1Z is designed to operate from an AVDD supply (5V to 20V), and VDD supply (2.6V to 3.6V).

### Jumpers

The evaluation board is configured with several jumpers. The jumpers enable the user to easily perform several different tests. The board is configured from the factory with the data sheet external components and the output amplifier connected. Reference Figure 3 for jumper location relative to the circuit schematic.

J1 is the test header output. J1 provides easy access to: ISL45042 output, EL5220 output, +10V supply, GND, +3V supply, CTL pin and the SET pin.

J2 and J3 provide power and input signal to the EL5220 respectively. Removing both jumpers will enable the user to evaluate the output of the ISL45042 by itself.

J4 enables and disables operation of the ISL45042. To enable operation, set J4 into position 1-2. This will pull the CE pin high. To disable operation, set J4 into position 2-3. This will pull the CE pin low.

J5, J6 and J7 allow the user to choose different resistor values than the ones already set on the board (for the biasing resistors and  $R_{SET}$ ).

J8 and J9 enable independent measurement of the ISL45042 VDD (+3V) and AVDD (+10V) supply currents.

### Operation

The ISL45042 provides an output sink current which is converted to a voltage via the external voltage divider. The equations that control the output voltage are given in Equation 1 and Equation 2. Figure 2 defines  $R_1$ ,  $R_2$  and  $R_{SET}$  used in Equation 1 and Equation 2. Table 1 lists the output voltages for the following conditions:  $R_1 = 200k\Omega$ ,  $R_2 = 243k\Omega$ ,  $R_{SET} = 24.9k\Omega$  and AVDD = 10V.

$$I_{OUT} = \frac{\text{Setting}}{128} \times \frac{AVDD}{20(R_{SET})} \quad (\text{EQ. 1})$$

$$V_{OUT} = \left( \frac{R_2}{R_1 + R_2} \right) AVDD \left( 1 - \frac{\text{Setting}}{128} \times \frac{R_1}{20(R_{SET})} \right) \quad (\text{EQ. 2})$$

NOTE: Where "Setting" is an integer between 1 and 128.

### Switches

There are three switches on the board. Reference Figure 1 for the location of switches on the board, and Figure 3 for switch location relative to the circuit schematic.

S1 is the EEPROM Program switch that supplies AVDD level voltage to the ISL45042 CTL pin. Any level over 4.9V on CTL pin will program the current counter value to the EEPROM.

S2 is the decrement switch that will cause the output voltage ( $V_{OUT}$  EL5220 or  $V_{OUT}$  ISL45042) to increase its value.

S3 is the increment switch that will cause the output voltage ( $V_{OUT}$  EL5220 or  $V_{OUT}$  ISL45042) to decrease its value.

CE pin has to be active high, (jumper J4 in the position 1-2) in order for the increment/decrement switches to have the effect on the output voltage. Also, CE has to be high in order to program the EEPROM.

Taking the CE pin low (inactive) will reset the counter to the last EEPROM programmed value.

Note: the  $0\Omega$  resistor (Figure 3, R2) makes the EL5220 a buffer. If other functionality is desired, please replace R2 with the desired value.

### Using the ISL45042EVAL1Z Board

Please make sure that the power supplies are connected properly.

Set the J4 jumper to a position 1-2 to enable the CE, and allow the counter to move. Use S2 and S3 switches to move the counter values (decrement and increment the counter). As long as the CE is active, the counter value should remain at the position chosen. The output levels (current/voltage) can be measured at the J1 test header.

When the desired counter value is reached, use the S1, PROG EEPROM, switch to write the value to the Non-Volatile EEPROM.

If the value is not written to the EEPROM, and the CE is pulled low, the counter will reset to the last programmed value.

The output of the ISL45042 could be observed at the J1 test header, pin 2 (when EL5220 disabled with J2 and J3 taken out). Otherwise, the output could be fed to the EL5220 and then the output of the Amplifier (buffer) observed at the pin 1 of J1.

**ISL45042EVAL1Z Picture**

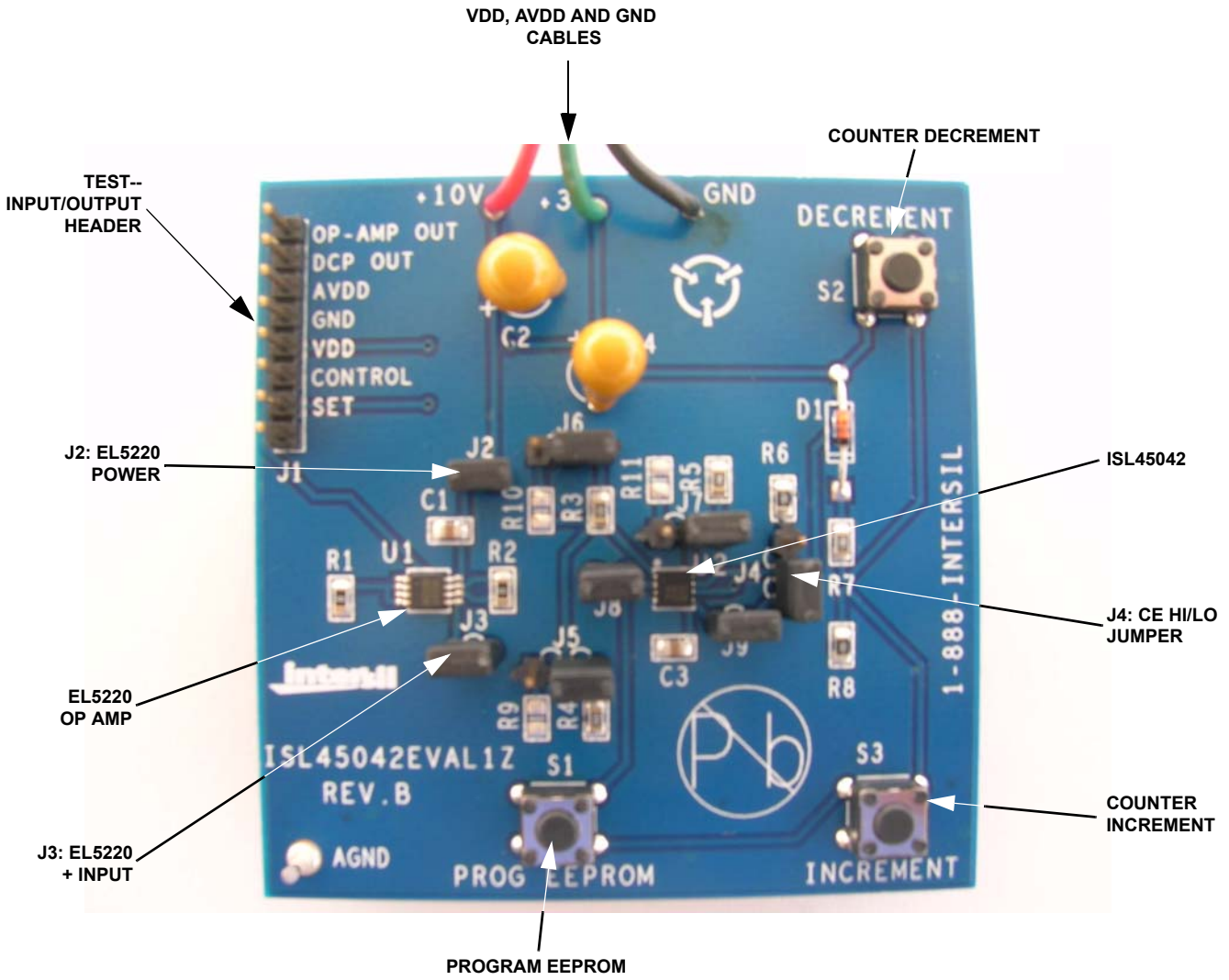

**NOTES:**

Jumpers J5, J6 and J7 allow user to choose different values of biasing and  $R_{SET}$  resistors.  
Jumpers J8 and J9 allow user to measure current draw of the ISL45042.

**FIGURE 1. ISL45042 EVAL BOARD**

**ISL45042EVAL1Z Block Diagram**

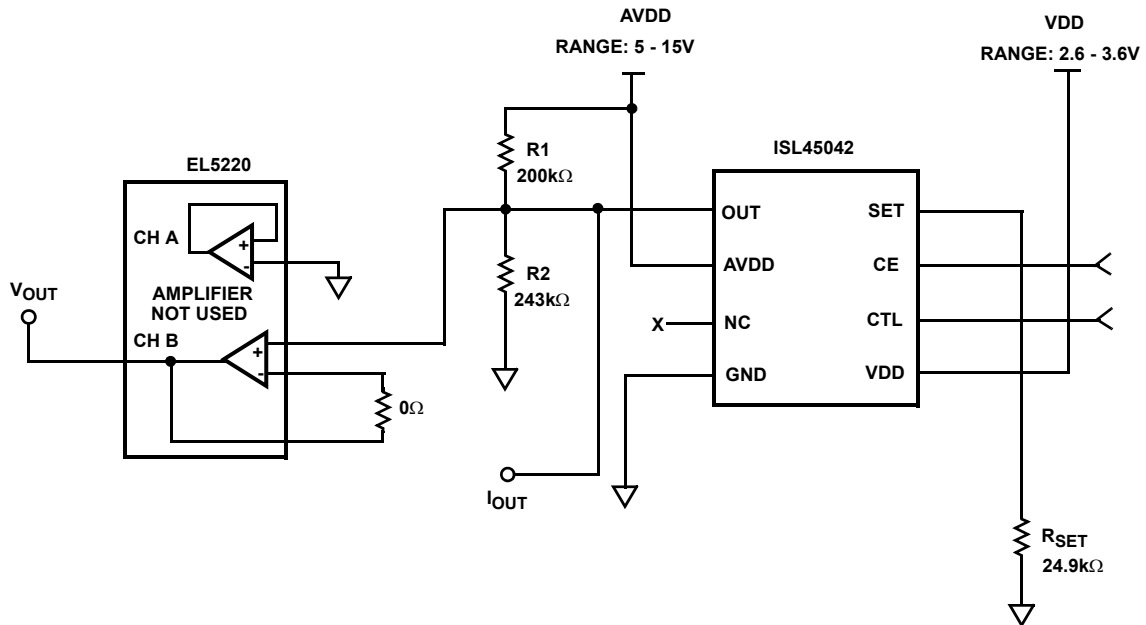

**FIGURE 2. SIMPLIFIED APPLICATION SCHEMATIC**

**TABLE 1.**

SETTING (INTEGER BETWEEN 1 AND 128)	V <sub>OUT</sub>
1	5.468
12	5.2788
23	5.0894
34	4.9001
45	4.7108
56	4.5215
67	4.3322
78	4.1429
89	3.9535
100	3.7642
111	3.5749
122	3.3856
128	3.2823

ISL45042EVAL1Z Schematics

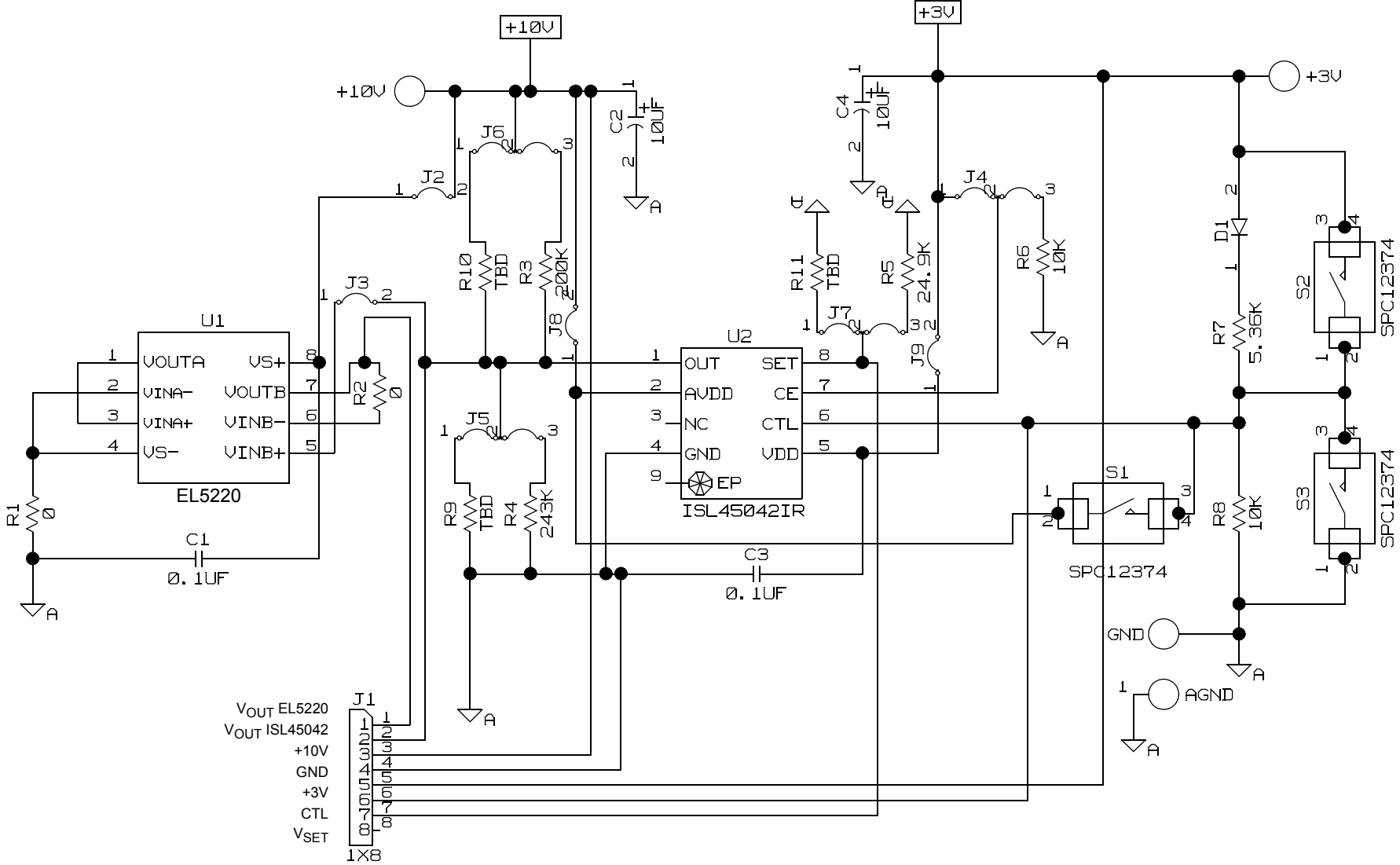

FIGURE 3. EVAL BOARD SCHEMATIC

**ISL45042EVAL1Z Bill of Materials**

TABLE 2. ISL45042EVAL1Z BOM

PART NUMBER	REF. DES.	QUAN.	VALUE	TOL.	POWER	PACKAGE	JEDEC	MANUF.	DESCRIPTION
160-2044-02-01-00	AGND	1				THOLE	TP80	Cambion	Test Post
1N914	D1	1				DO35	DO-35	Various	Generic Diode
22-28-4083	J1	1				SIP	CONN-1X8	Molex	Eight Pin Connector Block
EL5220	U1	1				EL5220CY	MSOP8	Elantec	Dual LN Amplifier
H1046-00104-50V10	C1, C3	2	0.1 $\mu$ F	10%		SMD-10%	SM0805	Generic	Multilayer Capacitor
H2512-00R00-1/10W	R1, R2	1	0	0%	1/10W	SMD-1%	SM0805	Generic	TFC Resistor
H2512-01002-1/10W1	R6, R8	3	10k	1%	1/10W	SMD-1%	SM0805	Generic	TFC Resistor
H2512-02003-1/10W1	R3	1	200k	1%	1/10W	SMD-1%	SM0805	Generic	TFC Resistor
H2512-02433-1/10W1	R4	1	243k	1%	1/10W	SMD-1%	SM0805	Generic	TFC Resistor
H2512-02492-1/10W1	R5	1	24.9k	1%	1/10W	SMD-1%	SM0805	Generic	TFC Resistor
H2512-05361-1/10W1	R7	1	5.36k	1%	1/10W	SMD-1%	SM0805	Generic	TFC Resistor
ISL45042IR	U2	1				TDFN	8DFN-3X3A	Intersil	VCOM
JUMPER-3-100	J4-J7	4				THOLE	JUMPER-3	Generic	Three Pin Jumper
JUMPER-2-100	J2, J3, J8, J9	4				THOLE	JUMPER-1	Generic	Two Pin Jumper
PAD_70C_43P	+10V, +3V, GND	3				THOLE	PAD-70C4	Generic	0.070 Pad with 0.043 Plated Thru Hole
SDTX-610-K	S1-S3	3				THOLE	SW_STDY-610-K	Bourns	Tactile Switch
T353K106K050AS	C2, C4	2	10 $\mu$ F	10%		RADIAL-10%	TANT-200	Kemet	Tantulum Capacitor
THREE TWISTED WIRE	+10V, +3V, GND	1	1'			RED, GREEN, BLACK			
MALE BANANA JACK	+10V, +3V, GND	3				RED, GREEN, BLACK			