

ISL5x61EVAL1, ISL5x61EVAL2

Evaluation Boards

AN9966
Rev 0.00
September 2001

Description

The ISL5x61EVAL1 and EVAL2 evaluation boards provide a quick and easy method for evaluating the ISL5761/5861/5961 (10-, 12-, or 14-bit), 130/210MSPS high speed DACs. EVAL1 is populated with an SOIC package and EVAL2 is populated with a TSSOP package. The board is configured so that the converter outputs differential current into a transformer circuit to form an output voltage. The amount of current out of the DAC is determined by an external resistor and either an internal or external reference voltage. The CMOS digital inputs have optional external termination resistors. The evaluation board includes a ribbon cable digital interface that is compatible with Intersil DUC (Digital Up Converter) evaluation boards like the ISL5217.

Features

- 210MSPS 10-, 12- or 14-Bit CMOS DAC
- Transformer-Coupled or Single-Ended SMA Outputs
- Interface compatible to the ISL5217 Digital Up Converter allows complete Baseband-to-IF Demonstration

Ordering Information

PART NUMBER	TEMP. RANGE (°C)	PACKAGE	NUMBER OF BITS	CLOCK SPEED
ISL5761EVAL1	25	SOIC	10	210MHz
ISL5861EVAL1	25	SOIC	12	210MHz
ISL5961EVAL1	25	SOIC	14	210MHz
ISL5761EVAL2	25	TSSOP	10	210MHz
ISL5861EVAL2	25	TSSOP	12	210MHz
ISL5961EVAL2	25	TSSOP	14	210MHz

Functional Block Diagram

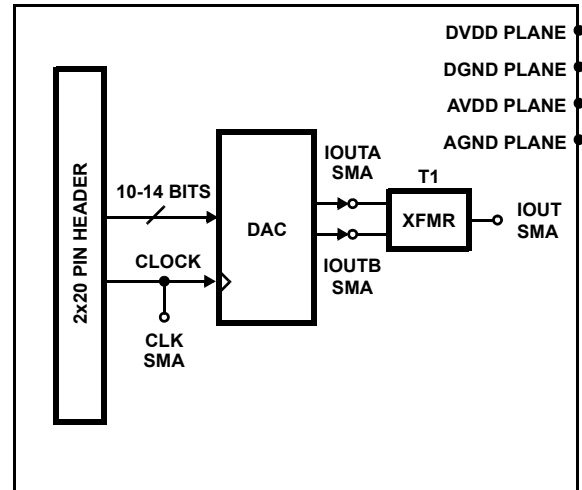

Getting Started

See Figure 1. A summary of the equipment, external supplies and signal sources needed to operate the board is given below:

1. +3.3V supply for ISL5x61 DAC.
2. Pattern generator (pattern source).
3. Square wave, DC-biased clock source (usually part of the pattern generator).
4. Spectrum analyzer or oscilloscope for viewing the output of the converter.

Attach the evaluation board to the power supply(s). Connect the bits from the data generator to the evaluation board using the 2x20 pin connector (J1). Connect the clock source to the evaluation board, either through the 2x20 pin connector (J1) or via the provided SMA (J2).

Using a coaxial cable with the proper SMA connector, attach the output of the converter, IOUT (J11), to the measurement equipment that will be evaluating the converter's performance. Make sure that the jumpers are in their proper placement (default placement should be J5 and J10 populated, all others not populated).

Set the clock signal and data levels to swing from 0-3V. Turn the power supply on. Turn the pattern and clock on and measure the result at the analog output SMA (J11).

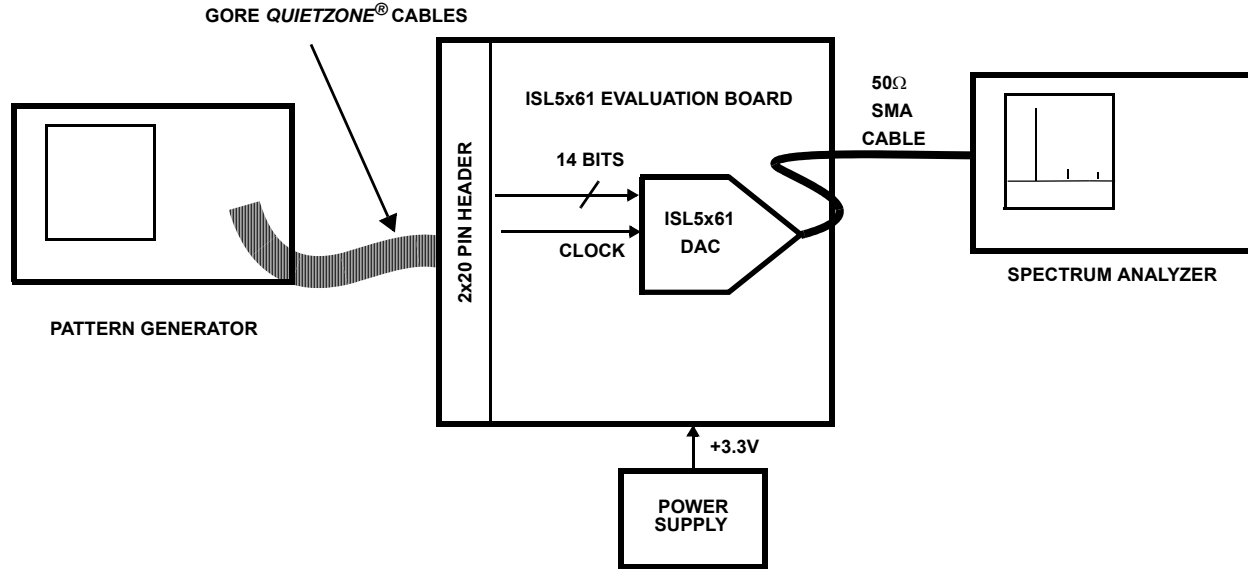

FIGURE 1. INTERSIL ISL5x61 EVALUATION SYSTEM SETUP BLOCK DIAGRAM

Board Options

Jumpers (Default State)

- J3 - Selects DAC Sleep Mode (OPEN)
- J4 - Selects External Reference (OPEN)
- J5 - Selects Internal Reference (SHORT)
- J6 - Selects IOUTA (OPEN)
- J7 - Selects IOUTB (OPEN)
- J10 - Grounds the Transformer Output (SHORT)

Output Transformer

- T1 - T1-1T (case style Mini-Circuits KK81)
- T2 - ADT1-1WT (case style Mini-Circuits CD542)

Clock

- 2x20 Pin Header (J1 - pin 19)
- SMA - J2

RSET

- Fixed Resistor - R34 (2kΩ = 20mA full scale output)
- Potentiometer - R35

Power Supply

- Split AVDD and DVDD
- Single VDD (by connecting them together prior to the inductors on the board)

Digital Inputs

The digital inputs are expecting 3V CMOS levels. The board is shipped without termination resistors so that most systems can drive the load. The board is configured so that the user can populate 50Ω termination resistors if required (R1-15). Consult the datasheet for the DAC for min/max amplitude requirements for the clock and data.

Analog Outputs

The transformer configuration is such that it expects to see a 50Ω load at the end of an RF cable. If the user wishes to evaluate the single-ended performance of the DAC, J6 and/or J7 will need to be populated, and R31/32 should be populated with 50Ω resistors (or a resistor of choice that does not cause the analog output to violate the output voltage compliance range specified in the datasheet.)

Board Schematics/Layout/BOM

The schematics, board plots, and bill of materials can be downloaded from the Intersil web site. Search on the DAC part number.

Other

The labels on the board for IOUTA (J8) and IOUTA (J9) are backwards. J8 should be IOUTA and J9 should be IOUTB.

ISL5x61 + ISL5217 Combo

The ISL5x61 evaluation board is designed to interface directly to an ISL5217 evaluation board. The ISL5217 is a 104MSPS Digital Up Converter. The ISL5217 can be used to generate 1-

4 narrowband carriers or 1-2 wideband carriers. Consult the ISL5217 documentation for detailed information on using the ISL5217 evaluation board.

To connect the two boards together, J4 on the ISL5217eval (DUC) is connected to J1 on the ISL5x61eval (DAC) via a 2x20 pin ribbon cable. The DAC board is configured as is stocked, except R16 is not populated. See Figure 2 for a block diagram of the two boards connected.

If a clock source is available that has both CLK and $\overline{\text{CLK}}$, the clocking of the two boards is simplified. CLK should connect to the DUC evaluation board at J11, with a T-connector that has a 50Ω terminator attached. $\overline{\text{CLK}}$ should go to the DAC evaluation board at J2 and also use a T-connector with a 50Ω terminator.

(Or, 50Ω terminators can be populated on the evaluation boards. See the board schematics for more information on doing this.)

If a generator with CLK and $\overline{\text{CLK}}$ is not available, a single clock source can be used. Connect a T-connector to J2 of the DAC board and another to J11 of the DUC board. Connect a DC-biased clock signal to the connector at J2, then connect J2 and J11 together with a short cable. Connect a 50Ω terminator to the other side of the T-connector at J11 on the DUC board. Sometimes the length of the clock cable running from the DAC board to the DUC board has to be adjusted to achieve adequate setup and hold times between DATA and CLK.

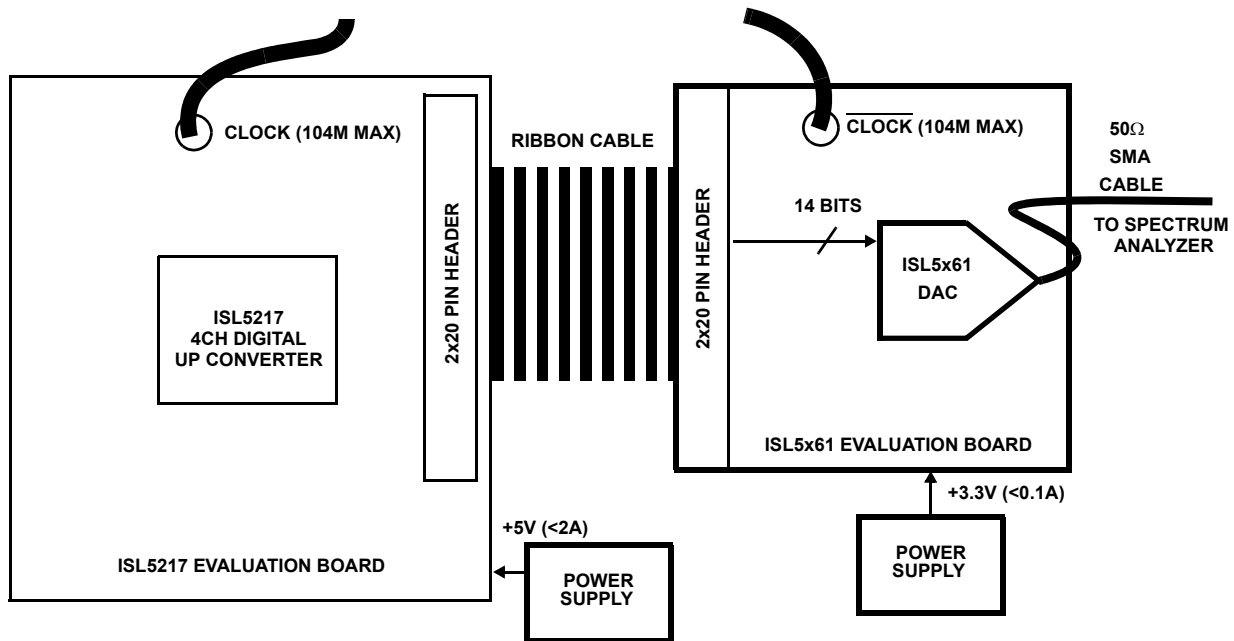

FIGURE 2. INTERSIL ISL5x61 + ISL5217 SETUP BLOCK DIAGRAM