

## ISL6228HIEVAL3Z

Evaluation Board

AN1322  
Rev 1.00  
August 22, 2007

### Introduction

The ISL6228HIEVAL3Z evaluation board demonstrates the performance of the ISL6228 dual-channel PWM controller. The ISL6228 features Intersil's Robust Ripple Regulator (R<sup>3</sup>) technology. Channel-1 output voltage is 1.05V or 1.2V, pending the state of switch S5. Channel-2 output voltage is 1.2V. Each channel has an on-board dynamic-load generator included for evaluating the transient-load response. It applies a 300μs pulse of 20A load across V<sub>O1</sub> and GND, and it also applies a 300μs pulse of 20A load across V<sub>O2</sub> and GND.

The contents of this document include:

- Recommended Test Equipment
- Interface Connections
- Switch Descriptions
- Test Point Descriptions
- Design Criteria
- Typical Performance
  - Efficiency
  - Start-up
  - Shut-down
  - Steady State, CCM
  - Steady State, DCM
  - Load-transient response
- Evaluation Board Documentation
  - Bill of Materials
  - Schematic
  - Silk-screen Plots
  - Board Layer Plots

**TABLE 1. DC/DC DESIGN CRITERIA**

PARAMETER	VALUE	UNITS
V <sub>IN</sub>	3.3 to 25	VDC
V <sub>O</sub>	0.6 to 5	VDC
Full-load	20	ADC
PWM Frequency	270, 300	kHz

### Recommended Equipment

- (QTY 2) Adjustable 25V, 3A Power Supply
- (QTY 1) Fixed 5V, 100mA Power Supply
- (QTY 1) Fixed 12V, 100mA Power Supply
- (QTY 1) Adjustable 20A Constant Current Electronic Load
- (QTY 1) Digital Voltmeter
- (QTY 1) Four-Channel Oscilloscope

### Interface Connections

- V<sub>IN1</sub>: Input voltage to the power stage of Channel-1
  - J14: V<sub>IN1</sub> positive power input
  - TP20: V<sub>IN1</sub> positive voltage sense
  - J14: V<sub>IN1</sub> return power input
  - TP21: V<sub>IN1</sub> return voltage sense
- V<sub>IN2</sub>: Input voltage to the power stage of Channel-2
  - J1: V<sub>IN2</sub> positive power input
  - TP9: V<sub>IN2</sub> positive voltage sense
  - J2: V<sub>IN2</sub> return power input
  - TP10: V<sub>IN2</sub> return voltage sense
- V<sub>O1</sub>: Regulated output voltage from Channel-1
  - J9: V<sub>O1</sub> positive power output
  - TP13: V<sub>O1</sub> positive voltage sense
  - J10: V<sub>O1</sub> return power output
  - TP14: V<sub>O1</sub> return voltage sense
- V<sub>O2</sub>: Regulated output voltage from Channel-2
  - J7: V<sub>O2</sub> positive power output
  - TP11: V<sub>O2</sub> positive voltage sense
  - J8: V<sub>O2</sub> return power output
  - TP12: V<sub>O2</sub> return voltage sense
- VCC: +5V input voltage
  - TP1: 5V positive input
  - TP2: 5V return input
- +12V: Input voltage for the dynamic-load generator
  - TP15: 12V positive input
  - TP16: 12V return input

## Test Set-up

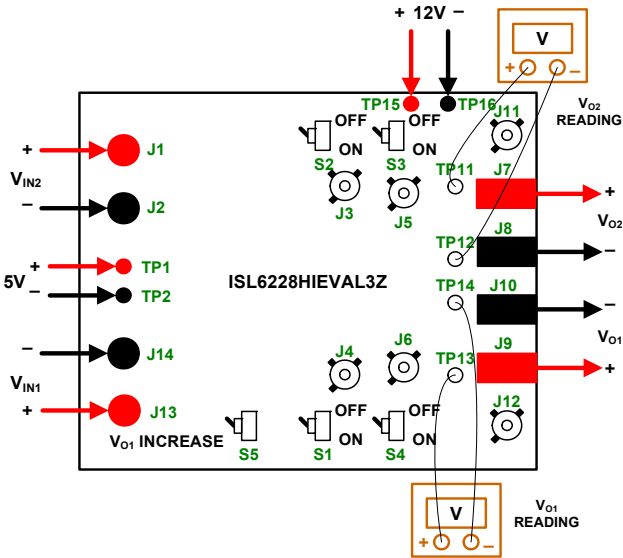

FIGURE 1. TEST SET-UP

## Switch Descriptions

- S1: Channel-1 Enable
  - OFF: Short the Channel-1 EN pin to GND (disable PWM)
  - ON: Allow the Channel-1 EN pin to pull-up to +5V (enable PWM)
- S4: Channel-1 Dynamic Load
  - OFF: On-board Channel-1 dynamic load disabled
  - ON: On-board Channel-1 dynamic load enabled
- S5: Channel-1  $V_{O1}$  Increase
  - OFF:  $V_{O1}$  is 1.05V, determined by  $R_{15}$  and  $R_{23}$ .
  - ON: Parallel  $R_{49}$  with  $R_{15}$ .  $V_{O1}$  is 1.2V.
- S2: Channel-2 Enable
  - OFF: Short the Channel-2 EN pin to GND (disable PWM)
  - ON: Allow the Channel-2 EN pin to pull-up to +5V (enable PWM)
- S3: Channel-2 Dynamic Load
  - OFF: On-board Channel-2 dynamic load disabled
  - ON: On-board Channel-2 dynamic load enabled

## Test Point Descriptions

- J4: Scope-probe socket for measuring PHASE1
- J6: Scope-probe socket for measuring  $V_{O1}$
- J12: Scope-probe socket for measuring the current of the Channel-1 on-board transient-load emulator
- J3: Scope-probe socket for measuring the PHASE2 node
- J5: Scope-probe socket for measuring  $V_{O2}$
- J11: Scope-probe socket for measuring the current of the Channel-2 on-board transient-load emulator
- TP1: Monitor the 5V positive input
- TP2: Monitor the 5V return input
- TP3: Monitor the PGOOD2 pin
- TP4: Monitor the PGOOD1 pin
- TP5: The common node of  $R_{24}$  and  $R_{20}$ ; Useful for Channel-1 loop gain measurement.
- TP6: The common node of  $R_{25}$  and  $R_{23}$ ; Useful for Channel-2 loop gain measurement
- TP7: The  $V_{O1}$  side of  $R_{24}$ ; Useful for Channel-1 loop gain measurement.
- TP8: The  $V_{O2}$  side of  $R_{25}$ ; Useful for Channel-1 loop gain measurement.
- TP9: Monitor the  $V_{IN1}$  positive input
- TP10: Monitor the  $V_{IN1}$  return input
- TP11: Monitor the positive  $V_{O1}$  output
- TP12: Monitor the  $V_{O1}$  return output
- TP13: Monitor the positive  $V_{O2}$  output
- TP14: Monitor the  $V_{O2}$  return output
- TP15: Monitor the 12V positive input
- TP16: Monitor the 12V return input
- TP17: Monitor the EN1 pin
- TP18: Monitor the gate of transistor  $Q_{18}$
- TP19: Monitor the EN2 pin
- TP20: Monitor the  $V_{IN2}$  positive input
- TP21: Monitor the  $V_{IN2}$  return input

**Typical Performance**

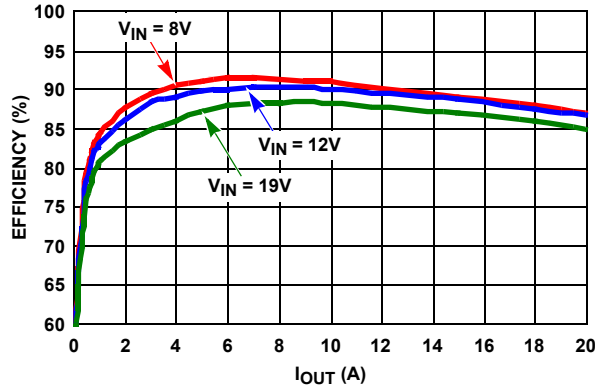

FIGURE 2. CHANNEL-1 EFFICIENCY AT  $V_O = 1.05V$

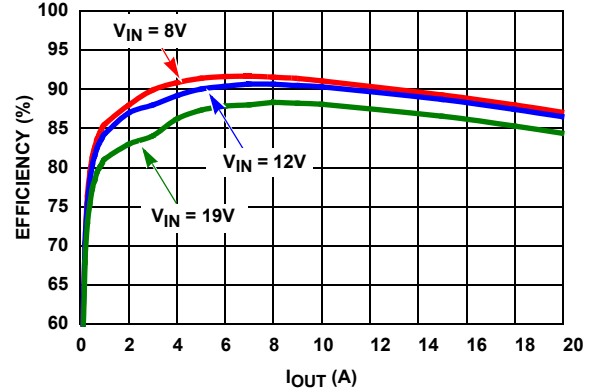

FIGURE 3. CHANNEL-2 EFFICIENCY AT  $V_O = 1.2V$

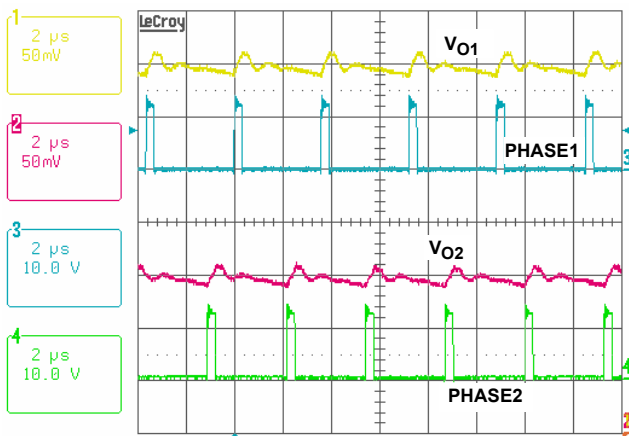

FIGURE 4. CCM STEADY-STATE OPERATION,  $V_{IN} = 12V$ ,  $V_{O1} = 1.05V$ ,  $I_{O1} = 5A$ ,  $V_{O2} = 1.8A$ ,  $I_{O2} = 6A$

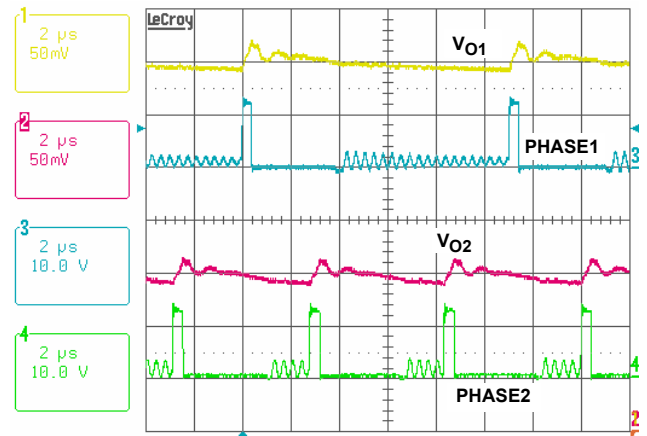

FIGURE 5. DCM STEADY-STATE OPERATION,  $V_{IN} = 12V$ ,  $V_{O1} = 1.5V$ ,  $I_{O1} = 2A$ ,  $V_{O2} = 1.8V$ ,  $I_{O2} = 2A$

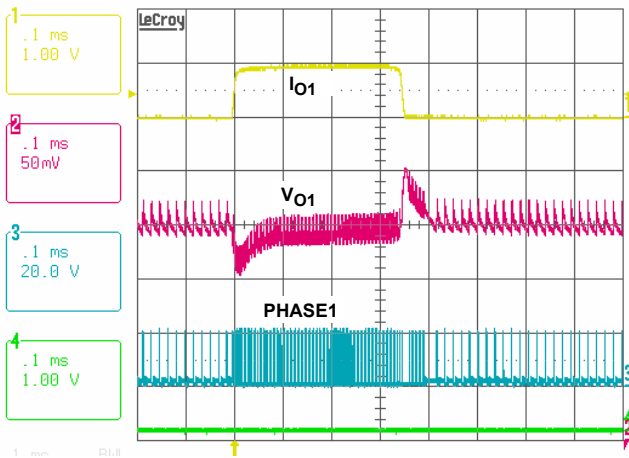

FIGURE 6. TRANSIENT RESPONSE,  $V_{IN} = 19V$ ,  $V_O = 1.05V$ ,  $I_O = 1A/21A @ 2.55A/\mu s$

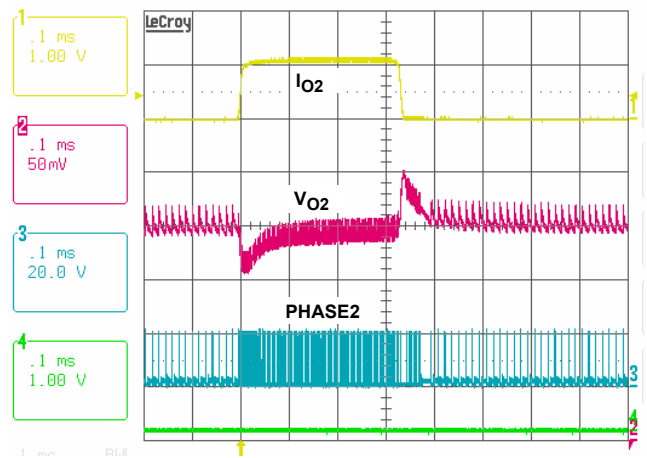
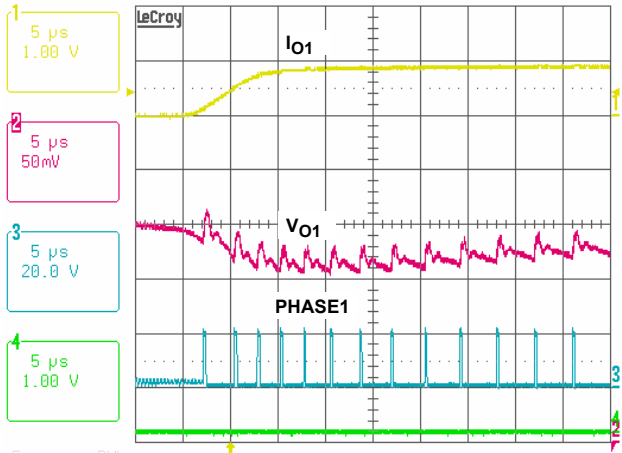
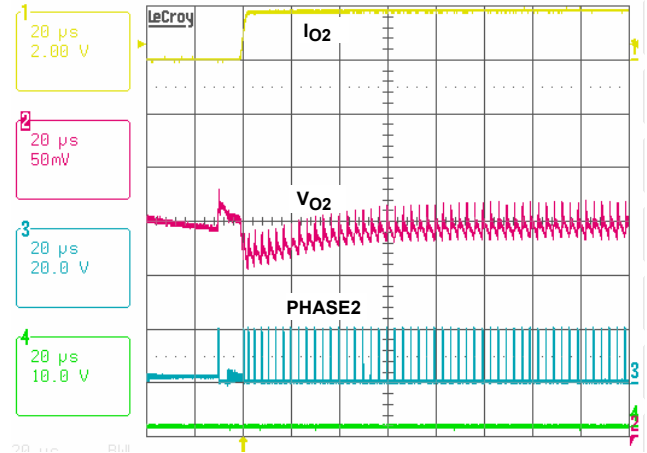

FIGURE 7. TRANSIENT RESPONSE,  $V_{IN} = 19V$ ,  $V_O = 1.2V$ ,  $I_O = 1A/21A @ 2.55A/\mu s$

**Typical Performance** (Continued)



**FIGURE 8. LOAD INSERTION RESPONSE,  $V_{IN} = 19V$ ,  $V_O = 1.05V$ ,  $I_O = 1A/21A @ 2.55A/\mu s$**



**FIGURE 9. LOAD INSERTION RESPONSE,  $V_{IN} = 19V$ ,  $V_O = 1.8V$ ,  $I_O = 0.1A/5.1A @ 2.55A/\mu s$**

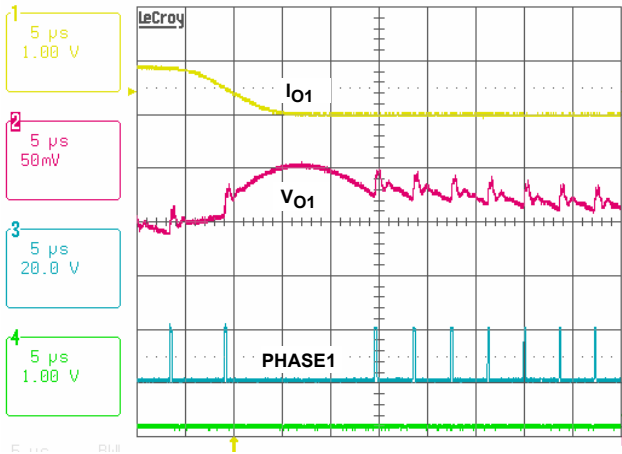

**FIGURE 10. LOAD RELEASE RESPONSE,  $V_{IN} = 19V$ ,  $V_O = 1.05V$ ,  $I_O = 1A/21A @ 2.55A/\mu s$**

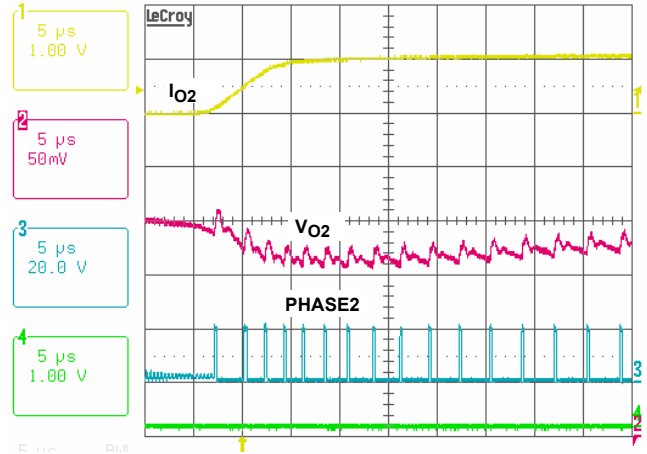

**FIGURE 11. LOAD RELEASE RESPONSE,  $V_{IN} = 19V$ ,  $V_O = 1.2V$ ,  $I_O = 1A/21A @ 2.55A/\mu s$**

**Bill of Materials**

QTY	REFERENCE	DESCRIPTION	MANUFACTURER	PART NUMBER
0	DNP (C8, C9)	CAP, RADIAL, 56µF, 25V, ROHS	SANYO	25SP56M
2	C1, C3	CAP, SMD, 0603, 1000pF, 16V, 10%, X7R, ROHS	VENKEL	H1045-00102-16V10-T
5	C20, C21, C37, C40, C41	CAP, SMD, 0603, 0.1µF, 16V, 10%, X7R, ROHS	MURATA	H1045-00104-16V10-T
6	C2, C7, C30, C31, C36, C39	CAP, SMD, 0603, 1µF, 16V, 20%, Y5V, ROHS	MURATA	H1045-00105-16V20-T
2	C18, C19	CAP, SMD, 0603, 10µF, 6.3V, 20%, X5R, ROHS	TDK	H1045-00106-6R3V20-T
2	C5, C6	CAP, SMD, 0603, 1500pF, 50V, 10%, X7R, ROHS	MURATA	H1045-00152-50V10-T
2	C14, C15	CAP, SMD, 0603, 0.22µF, 16V, 10%, X7R, ROHS	TDK	H1045-00224-16V10-T
2	C4, C38	CAP, SMD, 0603, 0.22µF, 25V, 20%, X7R, ROHS	VENKEL	H1045-00224-25V20-T
4	C32 to C35	CAP, SMD, 0805, 10µF, 16V, 10%, X5R, ROHS	PANASONIC	H1046-00106-16V10-T
2	C16, C17	CAP, SMD, 1206, 1µF, 25V, 20%, X5R, ROHS	PANASONIC	H1065-00105-25V20-T
4	C10 to C13	CAP, SMD, 1206, 10µF, 25V, 20%, X5R, ROHS	PANASONIC	H1065-00106-25V20-T
8	C22 to C29	CAP-LOW ESR, SMD, D3L, 330µF, 6.3V, 20%, POSCAP, ROHS	SANYO	6TPF330M9L
2	J1, J13	CONN-GEN, BIND.POST, INSUL-RED, THMBNUT-GND	JOHNSON COMPONENTS	111-0702-001
2	J2, J14	CONN-GEN, BIND.POST, INSUL-BLK, THMBNUT-GND	JOHNSON COMPONENTS	111-0703-001
0	J3 to J6, J11, J12	CONN-SCOPE PROBE TEST POINT, PCB MNT	TEKTRONIX	131-4353-00
4	TP1, TP2, TP15, TP16	CONN-TURRET, TERMINAL POST, TH, ROHS	KEYSTONE	1514-2
15	TP3 to TP14, TP17 to TP19	CONN-MINI TEST POINT, VERTICAL, WHITE, ROHS	KEYSTONE	5002
0	DNP (D3, D4)	DIODE-SCHOTTKY, SMD, SMB, 2P, 40V, 3A LOW VF, Pb-FREE	DIODES INC.	B340LB-13-F-T
2	D5, D6	DIODE-SCHOTTKY, SMD, SOT23, 3P, 30V, 200mA, DUAL DIODE	FAIRCHILD	BAT54S-T
2	D1, D2	LED, SMD, 4P, OTHER, POLARIZED RED/GRN	LUMEX	SSL-LXA3025IGC
2	L1, L2	PWR CHOKE COIL, SMD, 13x12.9, 0.82µH, 20%, 33A, ROHS	Vishay	IHLP5050FDERR82M01
2	U2, U3	IC-HI FREQ BRIDGE DRIVER, 8P, SOIC, 100V, ROHS	INTERSIL	HIP2100IBZ
1	U1	IC-DUAL CHANNEL CONTROLLER, 28P, QFN, ROHS	INTERSIL	ISL6228HRZ
5	Q11 to Q14, Q18	TRANSISTOR, N-CHANNEL, 3LD, SOT-23, 60V, 115mA, ROHS	DIODES INC.	2N7002-7-F-T
0	DNP (Q5, Q10)	TRANSISTOR-DUAL N-CHANNEL, 8P, SOIC, 30V, 7.5A, ROHS	FAIRCHILD	FDS6990AS
4	Q1, Q2, Q6, Q7	TRANSIST-MOS, N-CHANNEL, 8P, SOIC, 30V, 9.1mΩ RDS, ROHS	INTERNATIONAL RECTIFIER	IRF7821PBF
4	Q3, Q4, Q8, Q9	TRANSIST-MOS, N-CHANNEL, 8P, SOIC, 30V, 4.0mΩ RDS, ROHS	INTERNATIONAL RECTIFIER	IRF7832PBF
2	Q15, Q16	TRANSIST-MOS, N-CHANNEL, SMD, TO-252, 30V, 20A, ROHS	VISHAY	SUD50N03-07-E3
4	R9, R52, R53, R54	RES, SMD, 0603, 2Ω, 1/10W, 1%, TF, ROHS	YAGEO	H2511-00020-1/10W1-T
0	DNP (R12, R13, R57, R58)	RESISTOR, SMD, 0603, 0Ω, 1/10W, TF, ROHS	KOA	H2511-00R00-1/10W-T
10	R10, R11, R24, R25, R48, R50, R55, R56, R59, R60	RESISTOR, SMD, 0603, 0Ω, 1/10W, TF, ROHS	KOA	H2511-00R00-1/10W-T
5	R7, R8, R21, R22, R51	RES, SMD, 0603, 10k, 1/10W, 1%, TF, ROHS	KOA	H2511-01002-1/10W1-T
2	R35, R37	RES, SMD, 0603, 4.12k, 1/10W, 1%, TF, ROHS	PANASONIC	H2511-04121-1/10W1-T

**Bill of Materials** (Continued)

QTY	REFERENCE	DESCRIPTION	MANUFACTURER	PART NUMBER
1	R49	RES, SMD, 0603, 422k, 1/10W, 1%, TF, ROHS	YAGEO	H2511-04223-1/10W1-T
2	R26, R27	RES, SMD, 0603, 2k, 1/10W, 1%, TF, ROHS	KOA	H2511-02001-1/10W1-T
1	R3	RES, SMD, 0603, 18.2k, 1/10W, 1%, TF, ROHS	KOA	H2511-01822-1/10W1-T
1	R4	RES, SMD, 0603, 22.1k, 1/10W, 1%, TF, ROHS	PANASONIC	H2511-02212-1/10W1-T
2	R34, R36	RES, SMD, 0603, 8.45k, 1/10W, 1%, TF, ROHS	KOA	H2511-08451-1/10W1-T
4	R1, R2, R5, R6	RES, SMD, 0603, 499 $\Omega$ , 1/10W, 1%, TF, ROHS	KOA	H2511-04990-1/10W1-T
2	R30, R31	RES, SMD, 0603, 49.9k, 1/10W, 1%, TF, ROHS	VENKEL	H2511-04992-1/10W1-T
1	R15	RES, SMD, 0603, 140k, 1/10W, 1%, TF, ROHS	YAGEO	H2511-01403-1/10W1-T
4	R16, R17, R28, R29	RES, SMD, 0603, 4.53k, 1/10W, 1%, TF, ROHS	ROHM	H2511-04531-1/10W1-T
2	R18, R19	RES, SMD, 0603, 845 $\Omega$ , 1/10W, 1%, TF, ROHS	VENKEL	H2511-08450-1/10W1-T
3	R14, R20, R23	RES, SMD, 0603, 105k, 1/10W, 1%, TF, ROHS	VENKEL	H2511-01053-1/10W1-T
0	DNP (R32)	RES, SMD, 1206, 1.5 $\Omega$ , 1/4W, 1%, TF, ROHS	VENKEL	H2513-001R5-1/4W1-T
2	R38, R40	RES, SMD, 1206, 1.5 $\Omega$ , 1/4W, 1%, TF, ROHS	VENKEL	H2513-001R5-1/4W1-T
3	R33, R39, R41	RES, SMD, 1206, 0.75 $\Omega$ , 1/2W, 1%, TF, ROHS	SUSUMU	RL1632R-R750-F
6	R42 to R47	RES, SMD, 1206, 0.2 $\Omega$ , 1/4W, 1%, TF, ROHS	VISHAY	WSL1206R2000FEA
5	S1 to S5	SWITCH-TOGGLE, SMD, ULTRAMINI, 1P, SPST MINI	C&K COMPONENTS	GT11MSCBE-T
4	J7 to J10	MTG HDWR, CBL.TERMINAL-LUG and SCREW, 6AWG to 14AWG	BERG/FCI	KPA8CTP

### ISL6228HIEVAL3Z Evaluation Board Schematic

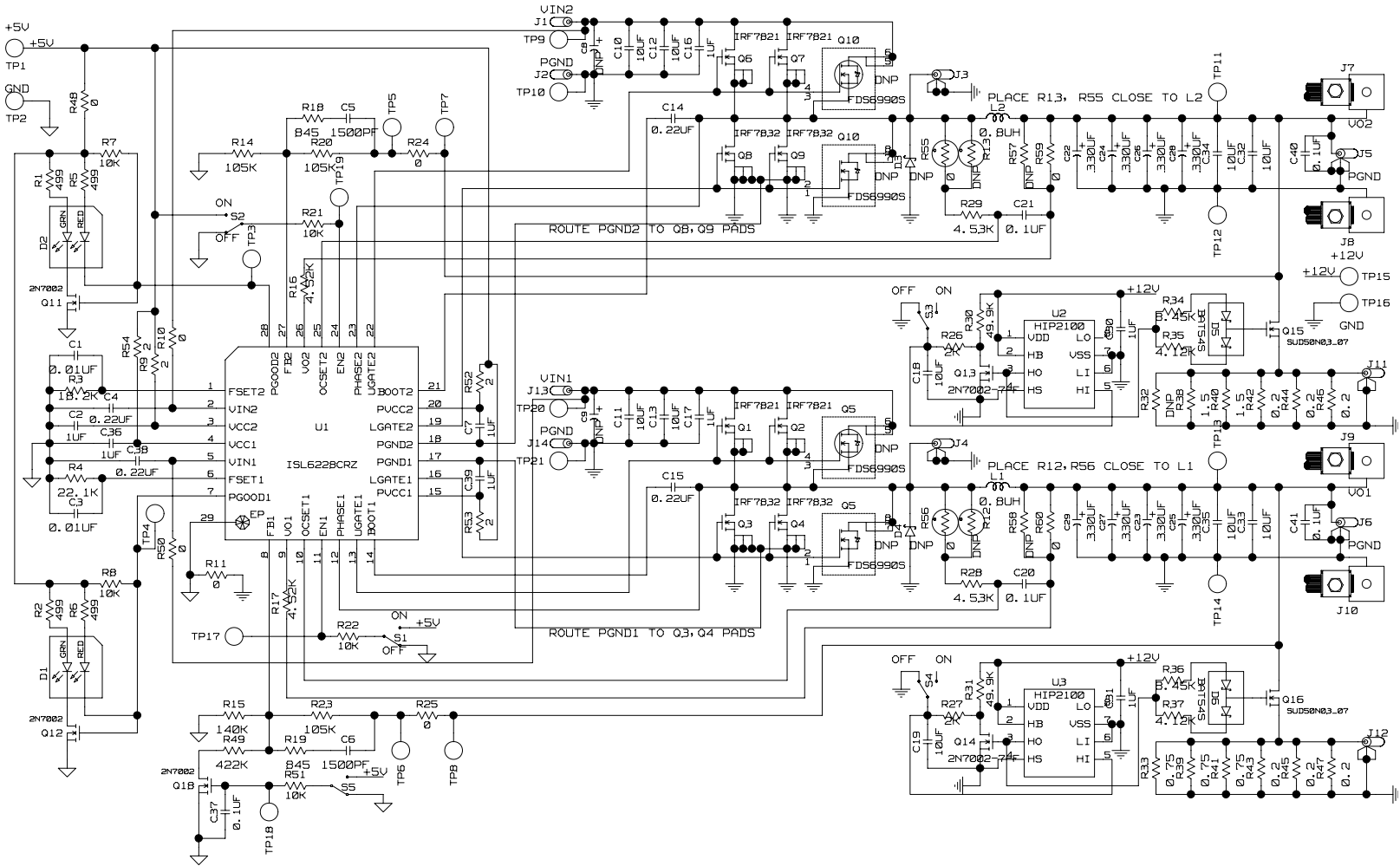

FIGURE 12. ISL6228HIEVAL3Z SCHEMATIC

ISL6228HIEVAL3Z Evaluation Board Layout

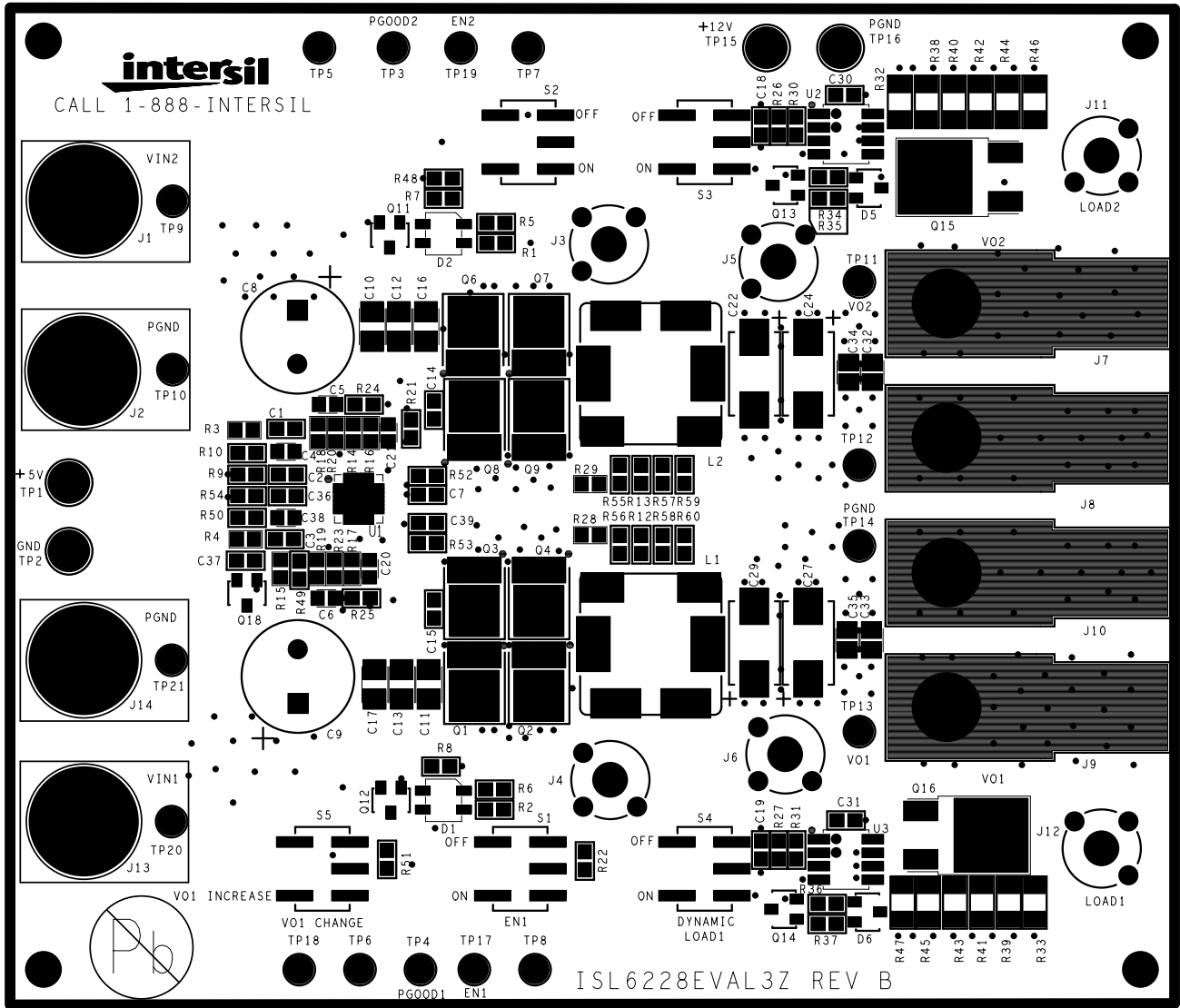

FIGURE 13. TOP SILKSCREEN



ISL6228HIEVAL3Z Evaluation Board Layout (Continued)

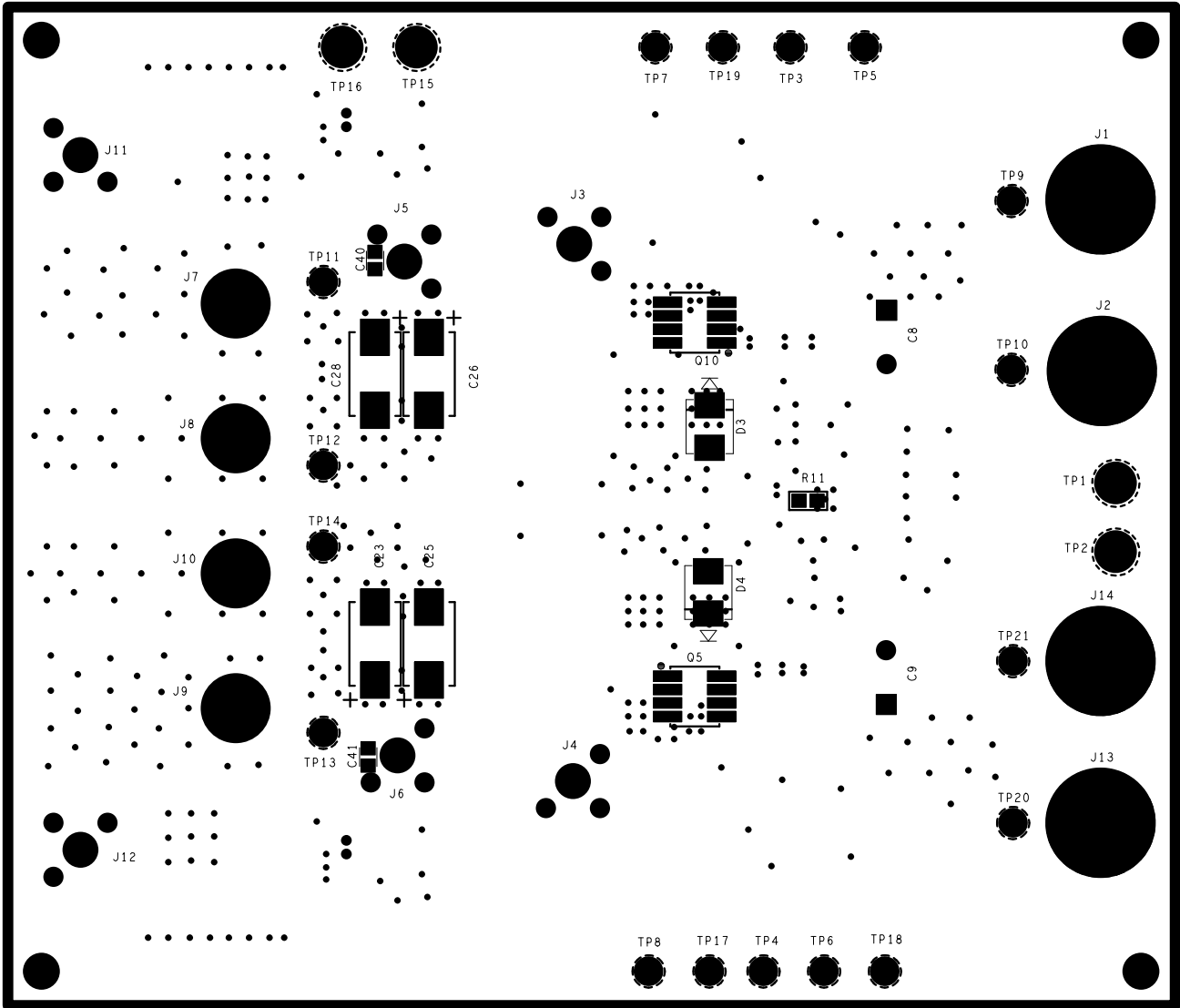

FIGURE 14. BOTTOM SILKSCREEN

**ISL6228HIEVAL3Z Evaluation Board Layout** (Continued)

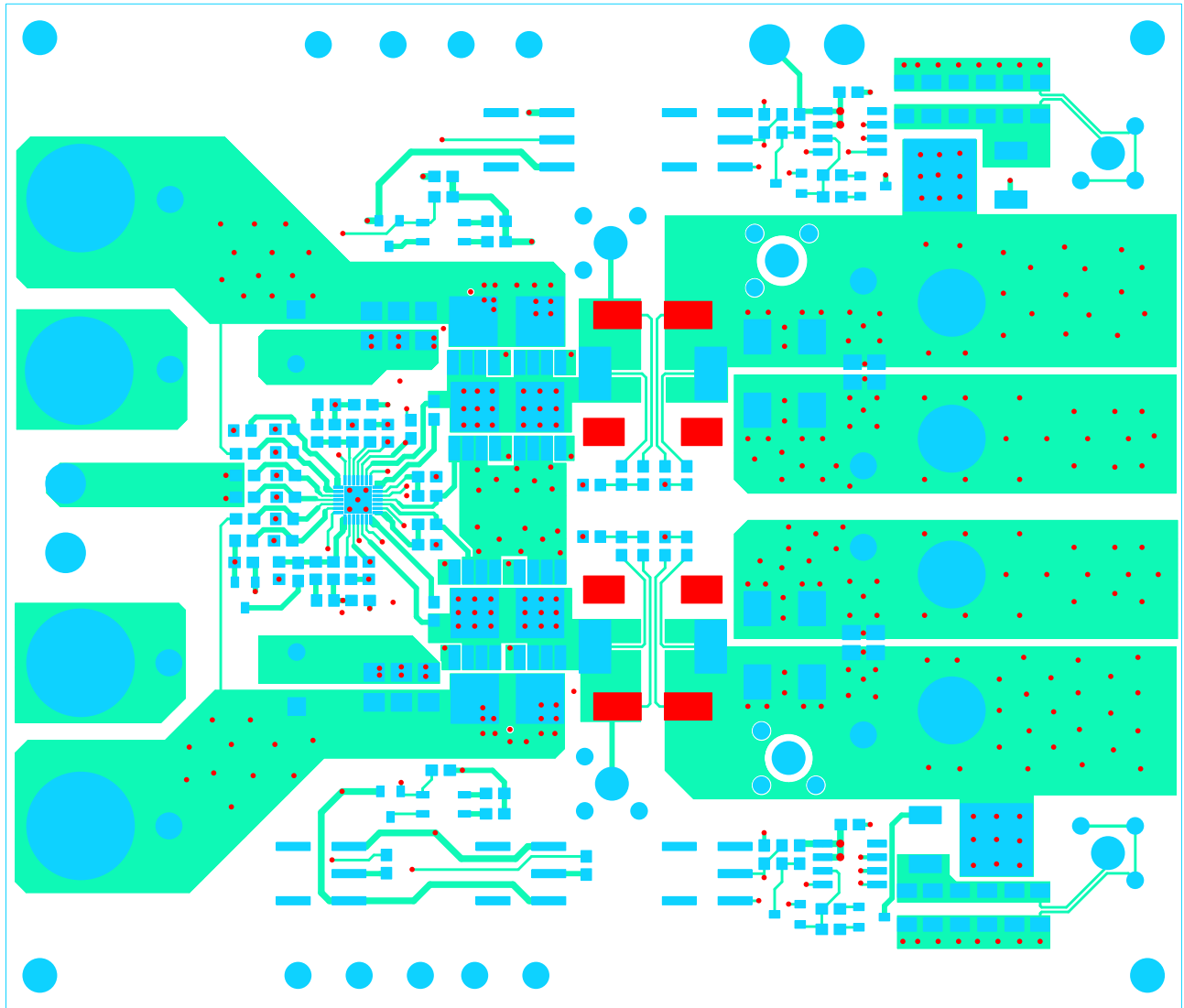

FIGURE 15. LAYER 1

**ISL6228HIEVAL3Z Evaluation Board Layout (Continued)**

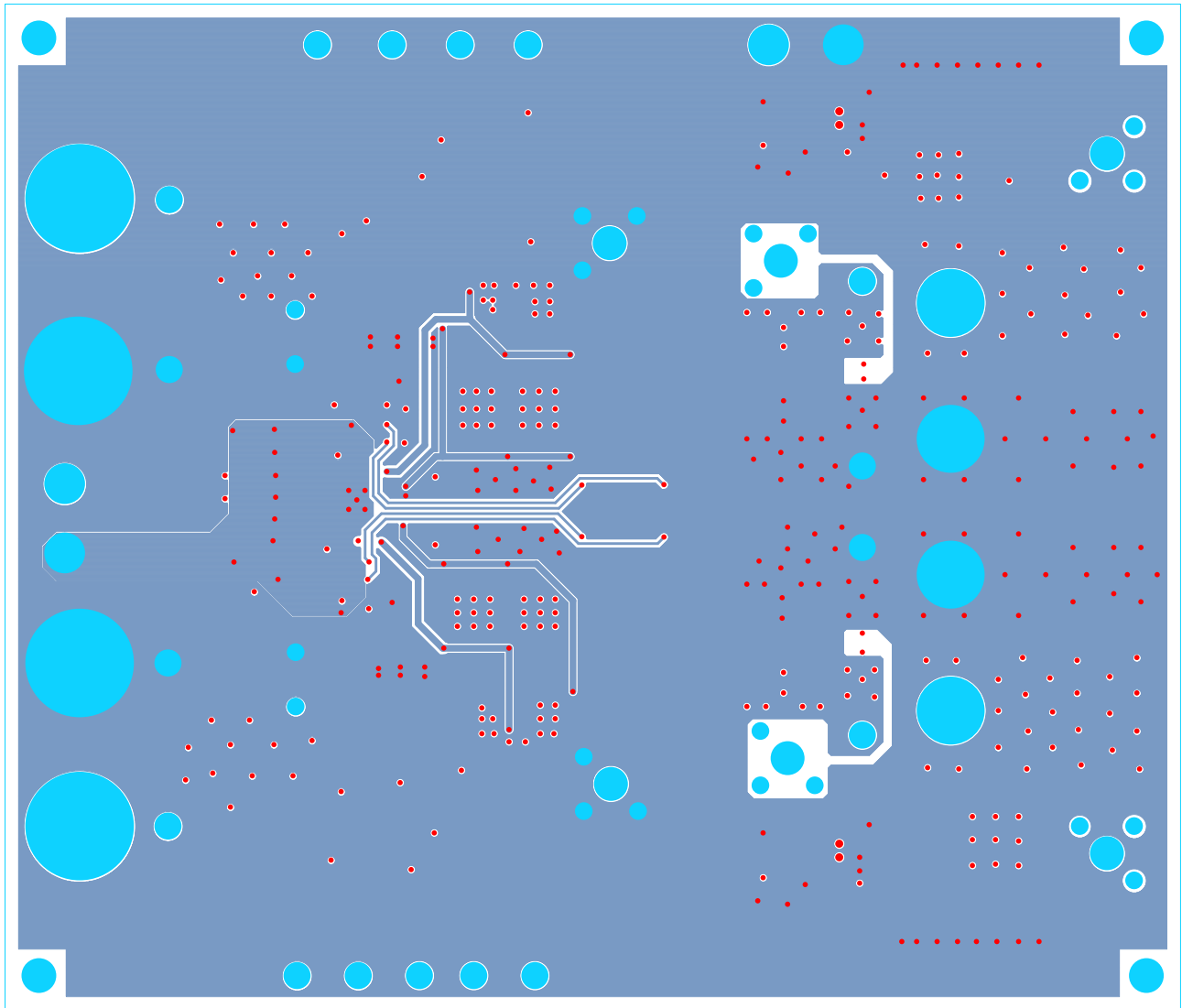

FIGURE 16. LAYER 2

**ISL6228HIEVAL3Z Evaluation Board Layout** (Continued)

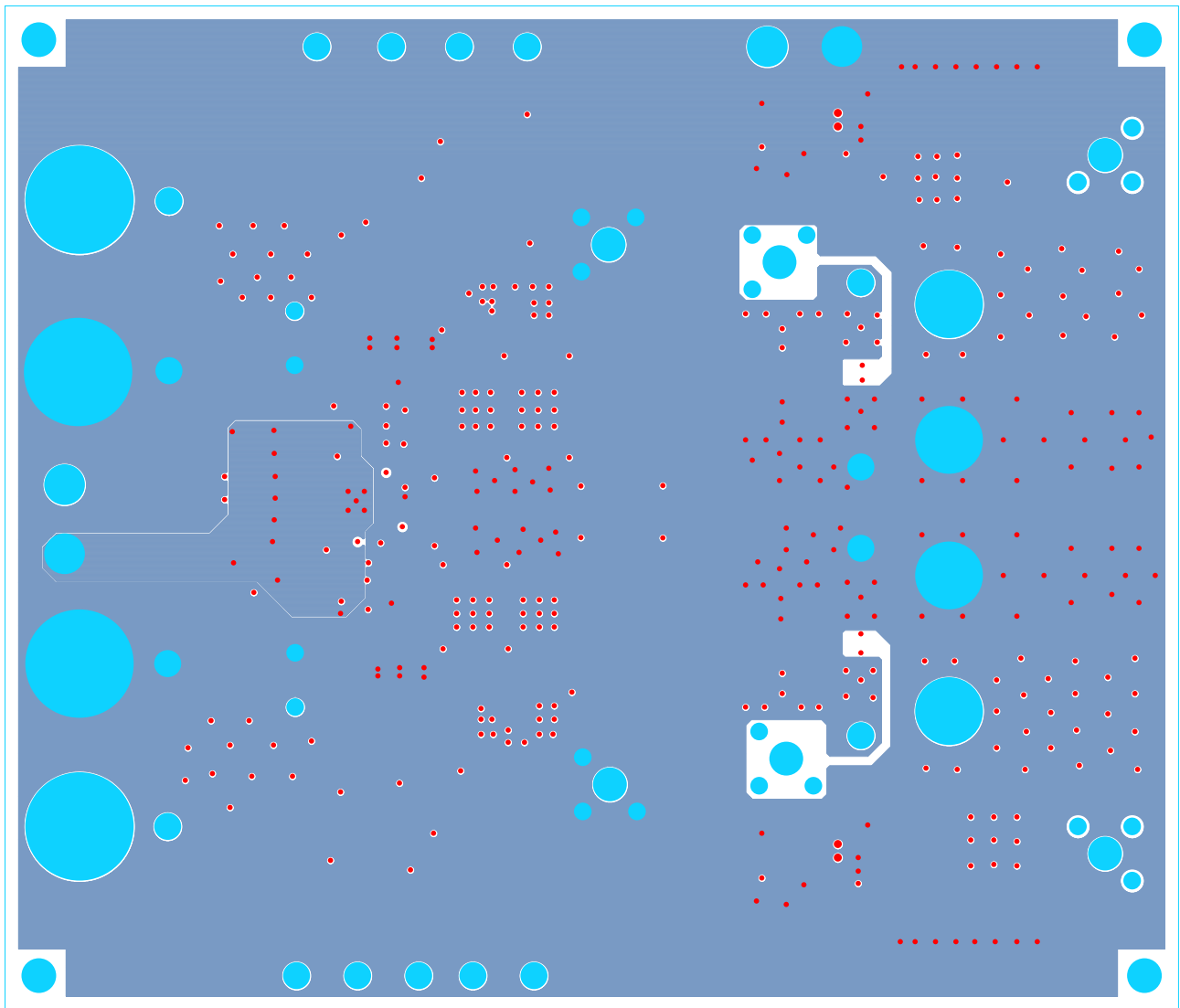

FIGURE 17. LAYER 3

**ISL6228HIEVAL3Z Evaluation Board Layout** (Continued)

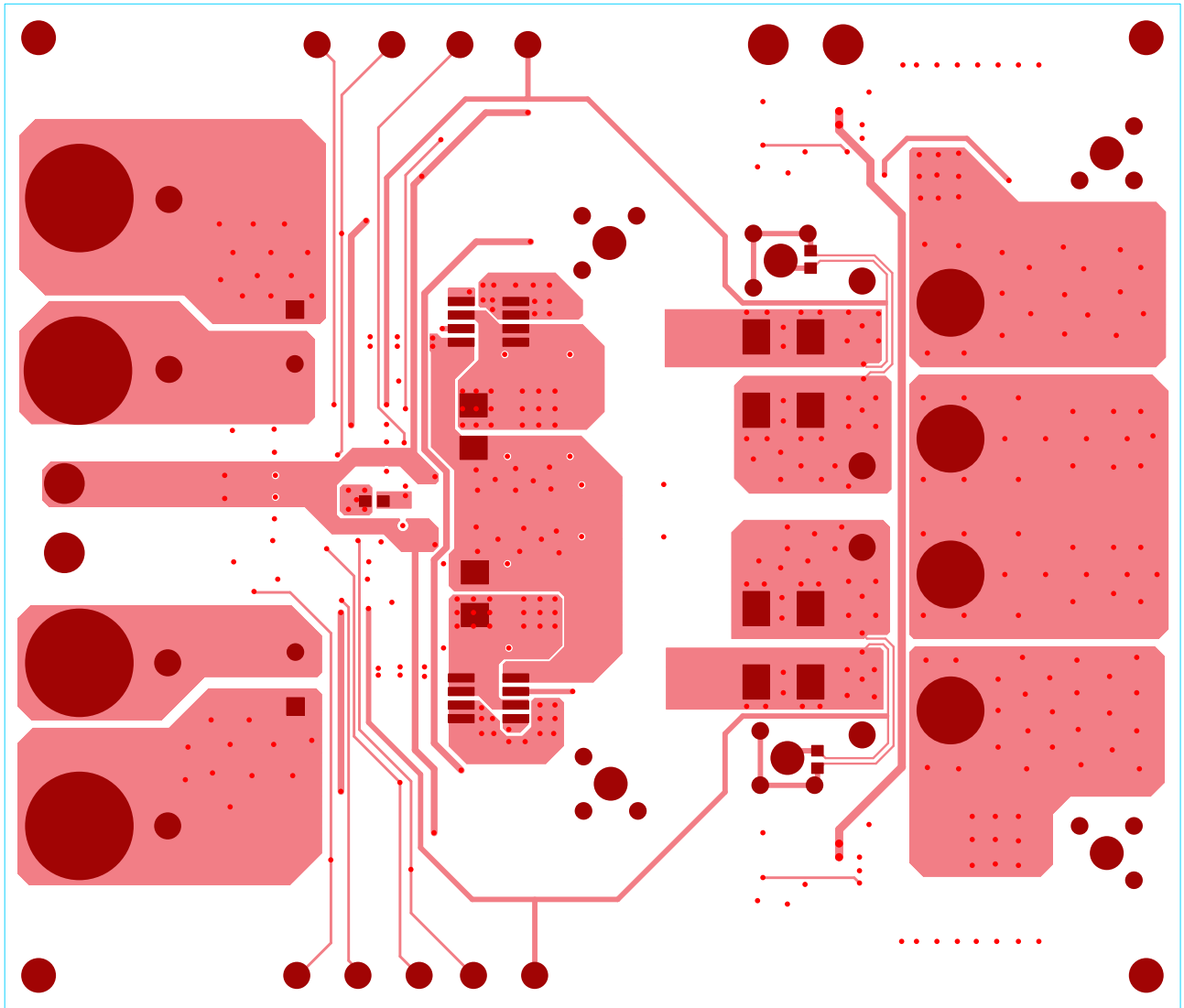

FIGURE 18. LAYER 4