

## ISL62883CEVAL2Z

Evaluation Board

AN1557  
Rev 0.00  
Apr 1, 2010

### Introduction

The ISL62883CEVAL2Z evaluation board demonstrates the performance of the ISL62883 multiphase synchronous-buck PWM  $V_{CORE}$  controller implementing Intel IMVP-6.5 protocol. The ISL62883 features Intersil's Robust Ripple Regulator ( $R^3$ ) technology. An on-board dynamic-load generator is included for evaluating the transient-load response. It applies a  $300\mu s$  pulse of approximately  $25m\Omega$  load across  $V_O$  and PGND.

Contents of this document include:

- Design Criteria
- Recommended Test Equipment
- Interface Connections
- Switch Descriptions
- DIP Switch Descriptions
- Jumper Descriptions
- Test Point Descriptions
- Evaluation Board Documentation
  - Bill of materials
  - Schematic
  - Silk-screen plots
  - Board layer plots

TABLE 1. DC/DC DESIGN CRITERIA

PARAMETER	VALUE	UNITS
$V_{IN}$	4.5 to 20	VDC
$V_O$	0 to 1.5	VDC
Full-load	75	ADC
PWM Frequency	300	KHz

### Recommended Equipment

- (QTY 1) Adjustable 25V, 10A Power Supply
- (QTY 1) Fixed 5V, 100mA Power Supply
- (QTY 1) Fixed 12V, 100mA Power Supply
- (QTY 1) Adjustable Constant Current Electronic Load
- (QTY 1) Digital Voltmeter
- (QTY 1) Four-Channel Oscilloscope

### Interface Connections

- $V_{IN}$ : Input Voltage to the Power Stage
  - J5:  $V_{IN}$  Positive Power Input
  - TP31:  $V_{IN}$  Positive Voltage Sense
  - J6:  $V_{IN}$  Return Power Input
  - TP32:  $V_{IN}$  Return Voltage Sense
- $V_O$ : Regulated Output Voltage
  - J11 and J12:  $V_O$  Positive Power Output
  - J13 and J14:  $V_O$  Return Power Output
- +5V: +5V Input Voltage
  - TP29: +5V Positive Input
  - TP30: +5V Return Input
- +12V: Input Voltage for the Dynamic-load Generator
  - TP3: 12V Positive Input
  - TP2: 12V Return Input

### Test Set-up

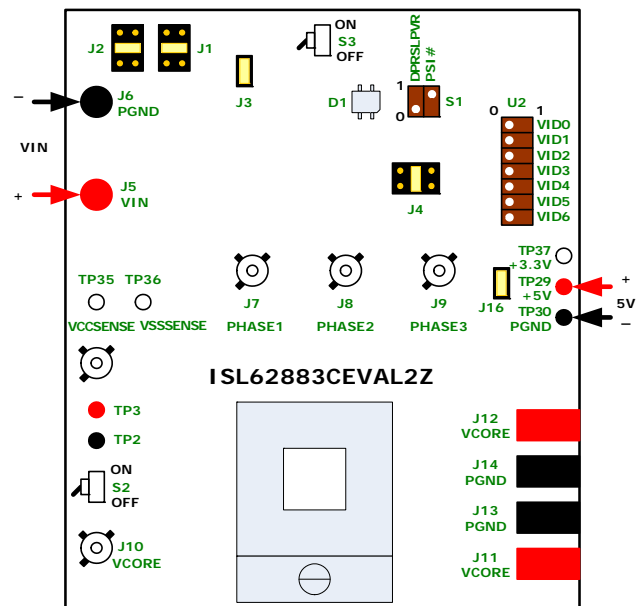

FIGURE 1. TEST SET-UP

### Switch Descriptions

- S3: Enable
  - OFF: Short the VR\_ON pin to GND (disable PWM)
  - ON: Allow the VR\_ON pin to pull-up to +5V (enable PWM)
- S5: Dynamic Load
  - OFF: On-board dynamic load disabled
  - ON: On-board dynamic load enabled

## DIP-Switch Descriptions

- S1: Set the control signals
  - S1.1: Set the DPRSLPVR signal
  - S1.2: Set the PSI# signal
- U2: Set the VID

## Jumper Descriptions

- J1: Set the ISEN2 pin configuration. ISEN2 can be connected to the power stage, tied to +5V, GND or left floating. Connect ISEN2 to the power stage when the ISL62883 is configured for 3-phase or 2-phase application. Tie ISEN2 to 5V when the ISL62883 is configured for 1-phase application.
- J2: Set the ISEN1 pin configuration. ISEN1 can be connected to the power stage, tied to +5V, GND or left floating. Connect ISEN1 to the power stage when the ISL62883 is configured for 3-phase, 2-phase application. Leave ISEN1 floating when the ISL62883 is configured for 1-phase application
- J3: If installed, the ISEN3/FB2 pin will be connected to the power stage. If uninstalled, the ISEN3/FB2 pin will be disconnected from the power stage. Install J3 when the ISL62883 is configured for 3-phase application. Uninstall J3 when the ISL62883 is configured for 2-phase or 1-phase application.
- J4: Set the PWM3 pin configuration. PWM3 can be connected to the ISL6208 driver, tied to +5V, GND or left floating. Connect PWM3 to the ISL6208 driver when the ISL62883 is configured for 3-phase application. Tie PWM3 to 5V when the ISL62883 is configured for 2-phase or 1-phase application.
- J16: If installed, the +5V rail supplies the +3.3V rail to the auxiliary circuit on the board. **DO NOT APPLY +3.3V TO TP37/TP30 WHILE J16 IS INSTALLED! IT'LL SHORT THE +5V AND THE +3.3V POWER SUPPLIES.** When measuring board efficiency, uninstall J16 and apply +3.3V to TP/37/TP30.

## Test-point Descriptions

- J7: Scope-probe socket for measuring PHASE1
- J8: Scope-probe socket for measuring PHASE2
- J9: Scope-probe socket for measuring PHASE3
- J10: Scope-probe socket for measuring  $V_O$
- J15: Scope-probe socket for measuring the current of the on-board transient-load emulator
- TP1: Monitor the on-board 1.2V power supply
- TP2: +12V power supply return input.
- TP3: +12V power supply positive input.
- TP4: Monitor the COMP pin
- TP5: Monitor the VW pin.
- TP6: Monitor the FB pin.

- TP7: Monitor the DPRSLPVR pin.
- TP8: Monitor the VR\_TT# pin.
- TP9: Monitor the PSI# pin.
- TP10: Monitor the ISEN3/FB2 pin.
- TP11: Monitor the ISEN2 pin.
- TP12: Input side of the compensator.
- TP13: Monitor the PGOOD pin.
- TP14: Monitor the VSEN pin.
- TP15: Monitor the ISEN1 pin.
- TP16: Monitor the CLK\_EN# pin.
- TP17: Monitor the VR\_ON pin
- TP18: Monitor the RTN pin.
- TP19: Monitor the positive side of C82.
- TP20: Monitor the negative side of C82.
- TP21: Monitor the VID6 pin.
- TP22: Monitor the VID5 pin.
- TP23: Monitor the VID4 pin.
- TP24: Monitor the VID3 pin.
- TP25: Monitor the VID2 pin.
- TP26: Monitor the VID1 pin.
- TP27: Monitor the VID0 pin.
- TP28: Monitor the IMON pin.
- TP29: +5V power supply positive input.
- TP30: +5V power supply return input.
- TP31:  $V_{IN}$  positive voltage sense
- TP32:  $V_{IN}$  return voltage sense
- TP33: Monitor MOSFET Q3 gate signal
- TP34: Monitor MOSFET Q9 gate signal.
- TP35: Monitor the VCCSENSE pin of the CPU socket U4.
- TP36: Monitor the VSSSENSE pin of the CPU socket U4.
- TP37: +3.3V power supply positive input.
- TP38: Monitor the VTT1 rail of the CPU socket U4.
- TP39: Monitor the VTT2 rail of the CPU socket U4.

## Bill of Materials

REFERENCE	QTY	VALUE	PART NUMBER	DESCRIPTION	PACKAGE	VENDOR
C1	1	0.01 $\mu$ F	H1045-00103-16V10	Multilayer Cap, 16V, 10%	SM0603	Generic
C11	1	390pF	H1045-00391-16V10	Multilayer Cap, 16V, 10%	SM0603	Generic
C12, C14	2	330pF	H1045-00331-16V10	Multilayer Cap, 16V, 10%	SM0603	Generic
C13	1	1000pF	H1045-00102-16V10	Multilayer Cap, 16V, 10%	SM0603	Generic
C15	DNP					
C16, C2, C22, C23, C26, C79	6	1 $\mu$ F	H1045-00105-16V20	Multilayer Cap, 16V, 20%	SM0603	Generic
C18	1	0.47 $\mu$ F	H1045-00474-16V10	Multilayer Cap, 16V, 10%	SM0603	Generic
C19		DNP				
C36, C37, C38, C8, C83	5	DNP				
C20, C45, C58	3	0.1 $\mu$ F	H1045-00104-16V10	Multilayer Cap, 16V, 10%	SM0603	Generic
C21	1	0.22 $\mu$ F	H1045-00224-16V10	Multilayer Cap, 16V, 10%	SM0603	Generic
C24, C25	2	56 $\mu$ F	25SP56M	Radial SP Series Cap, 25V, 20%	CASE-CC	Sanyo
C27, C28, C29, C33, C34, C35, C80	7	10 $\mu$ F	H1065-00106-25V20	Multilayer Cap, 25V, 20%	SM1206	Generic
C3	1	150pF	H1045-00151-16V10	Multilayer Cap, 16V, 10%	SM0603	Generic
C39, C44, C52, C57	4	270 $\mu$ F	EEFSX0D271E4	POSCAP, 2V, 4.5m $\Omega$		Panasonic
C4	1	1000pF	H1045-00102-16V10	Multilayer Cap, 16V, 10%	SM0603	Generic
C40 to C43, C47 to C50, C54 to C56, C59 to C61, C63 to C68, C71 to C74	24	10 $\mu$ F	GRM21BR61C106KE15L	Multilayer Cap, 6.3V, 20%	SM0805	Murata
C5, C53, C62, C69, C70, C75 to C78	9	DNP				
C6	1	39pF	H1045-00390-16V10	Multilayer Cap, 16V, 10%	SM0603	Generic
C7, C9, C10, C17, C30, C31, C32	7	0.22 $\mu$ F	H1045-00224-16V10	Multilayer Cap, 16V, 10%	SM0603	Generic
C81	1	820pF	H1045-00821-16V10	Multilayer Cap, 16V, 10%	SM0603	Generic
C82	1	0.039 $\mu$ F	H1045-00393-16V10	Multilayer Cap, 16V, 10%	SM0603	Generic
D1	1		SSL-LXA30251GC	3mmx2.5mm Surface Mount Red/Green LED	LED_3x2_5MM	Lumex
J1, J2, J4	3		67996-272	2x3 Header, 2.54mm(0.100) Pitch	CONN2x3	Berg/FCI
J10	1		131-4353-00	Scope Probe Test Point PCB Mount	TEK131-4353-00	Tektronix
J15, J7, J8, J9	0	DNP				
J11 to J14	4		KPA8CTP	Wire Connector Lug	KPA8CTP	Burndy
J3, J16	2		69190-202	2 Pin Header 2.54mm (0.100) Pitch	CONN2	Berg/FCI
J5	1		111-0702-001	Binding Post Red	111-07XX-001	Johnson-Comp
J6	1		111-0703-001	Binding Post Black	111-07XX-001	Johnson-Comp
L1, L2, L3	3	0.36 $\mu$ H	MPCH1040LR36	Inductor, Inductance 20%, DCR 7%		NEC-Tokin

**Bill of Materials** (Continued)

REFERENCE	QTY	VALUE	PART NUMBER	DESCRIPTION	PACKAGE	VENDOR
Q1, Q14	2		2N7002-7-F	N-Channel EMF Effect Transistor (Pb-Free)	SOT23	Fairchild
Q15	1		SUD50N03-07	N-Channel 30V (D-S) MOSFET	TO-252AA	Vishay
Q2, Q4, Q6, Q8, Q10, Q12	6		IRF7821	N-Channel Power MOSFET Power Switching	PWRPAK_SO8	IR
Q3, Q5, Q7, Q9, Q11, Q13	6		IRF7832	N-Channel Power MOSFET Power Switching	PWRPAK_SO8	IR
R1	1	49.9	H2511-049R9-1/16W1	Thick Film Chip Resistor, 1%	SM0603	Generic
R10	1	536	H2511-05360-1/16W1	Thick Film Chip Resistor, 1%	SM0603	Generic
R102	1	49.9k	H2511-04992-1/16W1	Thick Film Chip Resistor, 1%	SM0603	Generic
R104, R105	2	249	H2511-02490-1/16W1	Thick Film Chip Resistor, 1%	SM0603	Generic
R106, R107	2	0.05	H2515-00R05-1W1-T	Thick Film Chip Resistor, 1%	SM2512	Generic
R108	1	0	H2511-00R00-1/16W1	Thick Film Chip Resistor, 1%	SM0603	Generic
R109	1	100	H2511-01000-1/16W1	Thick Film Chip Resistor, 1%	SM0603	Generic
R11	1	2.37k	H2511-02371-1/16W1	Thick Film Chip Resistor, 1%	SM0603	Generic
R12, R13, R15, R103	4	499	H2511-04990-1/16W1	Thick Film Chip Resistor, 1%	SM0603	Generic
R16	1	147k	H2511-01473-1/16W1	Thick Film Chip Resistor, 1%	SM0603	Generic
R17, R18	2	10	H2511-00100-1/16W1	Thick Film Chip Resistor, 1%	SM0603	Generic
R19, R23	2	1.91k	H2511-01911-1/16W1	Thick Film Chip Resistor, 1%	SM0603	Generic
R21, R28, R31, R36, R39, R43, R45, R46, R49, R51, R71, R72, R73	13	10k	H2511-01002-1/16W1	Thick Film Chip Resistor, 1%	SM0603	Generic
R2, R8, R9, R26, R55, R74, R75, R76, R78, R81, R83, R84, R85, R86, R110	16	DNP				
R14, R112, R20, R22, R24, R25, R27, R29, R32, R33, R34, R40, R52, R53, R54, R56, R57, R58	18	0	H2511-00R00-1/16W1	Thick Film Chip Resistor, 1%	SM0603	Generic
R30	1	604	H2511-06040-1/16W1	Thick Film Chip Resistor, 1%	SM0603	Generic
R35	1	0	H2511-00R00-1/16W1	Thick Film Chip Resistor, 1%	SM0603	Generic
R37, R88, R90, R92	4	1	H2511-01R00-1/16W1	Thick Film Chip Resistor, 1%	SM0603	Generic
R38	1	11k	H2511-01102-1/16W1	Thick Film Chip Resistor, 1%	SM0603	Generic
R4	1	DNP				
R41	1	2.61k	H2511-02611-1/16W1	Thick Film Chip Resistor, 1%	SM0603	Generic
R42	1	10k NTC	ERT-J1VR103J	Thermistor, 10k NTC	SM0603	Panasonic
R44	1	DNP				
R47	1	0	H2511-00R00-1/16W1	Thick Film Chip Resistor, 1%	SM0603	Generic
R48	1	DNP				
R5, R80	2	100	H2511-01000-1/16W1	Thick Film Chip Resistor, 1%	SM0603	Generic
R50	1	8.25k	H2511-08251-1/16W1	Thick Film Chip Resistor, 1%	SM0603	Generic

**Bill of Materials** (Continued)

REFERENCE	QTY	VALUE	PART NUMBER	DESCRIPTION	PACKAGE	VENDOR
R59,R60,R61	3			Solder Joint (Heavy Duty)		
R6	1	8.66k	H2511-08661-1/16W1	Thick Film Chip Resistor, 1%	SM0603	Generic
R62, R64, R66, R87, R89, R91	6	0	H2511-00R00-1/16W1	Thick Film Chip Resistor, 1%	SM0603	Generic
R63, R65, R67	3	3.65k	H2512-03651-1/16W1	Thick Film Chip Resistor, 1%	SM0805	Generic
R68, R69, R70, R77, R79, R82	6	DNP				
R7	1	324k	H2511-03243-1/16W1	Thick Film Chip Resistor, 1%	SM0603	Generic
R93, R94, R95, R99, R100, R101, R111, R113	8	DNP				
R96, R97, R98	3			Solder Joint (Heavy Duty)		
S1	1		SD02H0SK	SD Series Low Profile Dip Switch	DIPSWMT-4	C&K
S2, S3	2		GT11MSCKE	SPDT On-None-On SMT Ultraminiature Toggle Switch	GT13MSCKE	C&K
S4	1		BAT54S	Schottky Barrier (Double) Diode	SOT23	Diodes
T2, T3, T29, T30	4		1514-2	Test Point Turret 0.15 Pad 0.1 Thole	TP-150C100P	Keystone
TP1, TP4 to TP28, TP31 to TP37	33		5002	Miniature White Test Point 0.100 Pad 0.040 Thole	MTP500X	Keystone
TP38, TP39	2	DNP				
U1	1		TLV431ASNT1	Low Volt Precision Adjustable Shunt Regulator	TSOP-5	On-Semi
U2	1		SD07H0SK	SD Series Low Profile Dip Switch	DIPSWMT-14	C&K
U3	1		ISL6208CBZ	Synchronous Rectified MOSFET Driver	SOIC8	Intersil
U4	1		rPGA989M	rPGA989 CPU Socket		Foxconn
U5	1		HIP2100IBZ	100V/2A Peak High Freq Half Bridge Driver (Pb-Free)	SOIC8	Intersil
U6	1		ISL62883HRZ	IMVP-6.5 PWM Controller	QFN-40	Intersil

# ISL62883CEVAL2Z Schematic

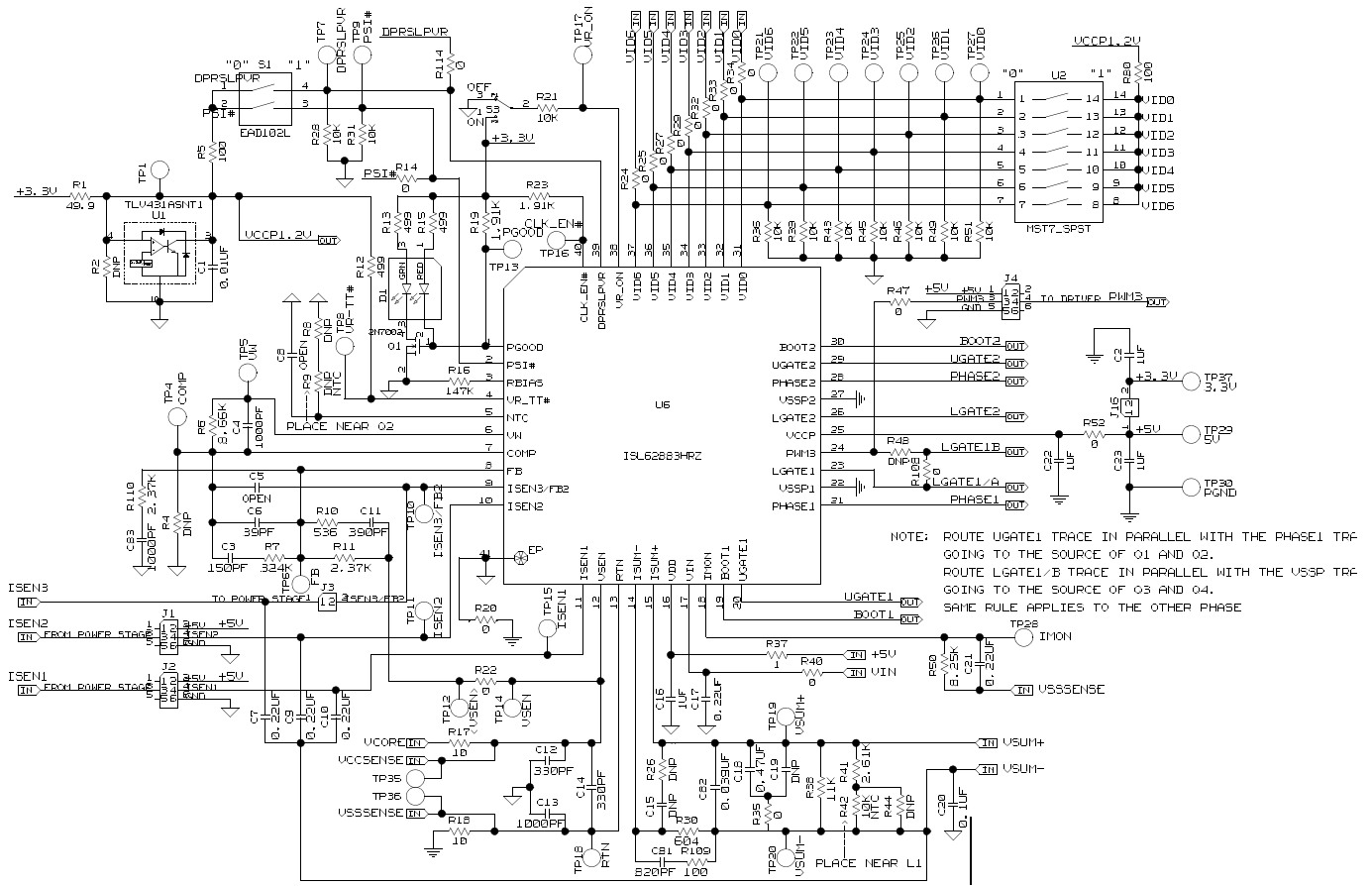

FIGURE 2. ISL62883CEVAL2Z SCHEMATICS, PAGE 1 OF 5

# ISL62883CEVAL2Z Schematic (Continued)

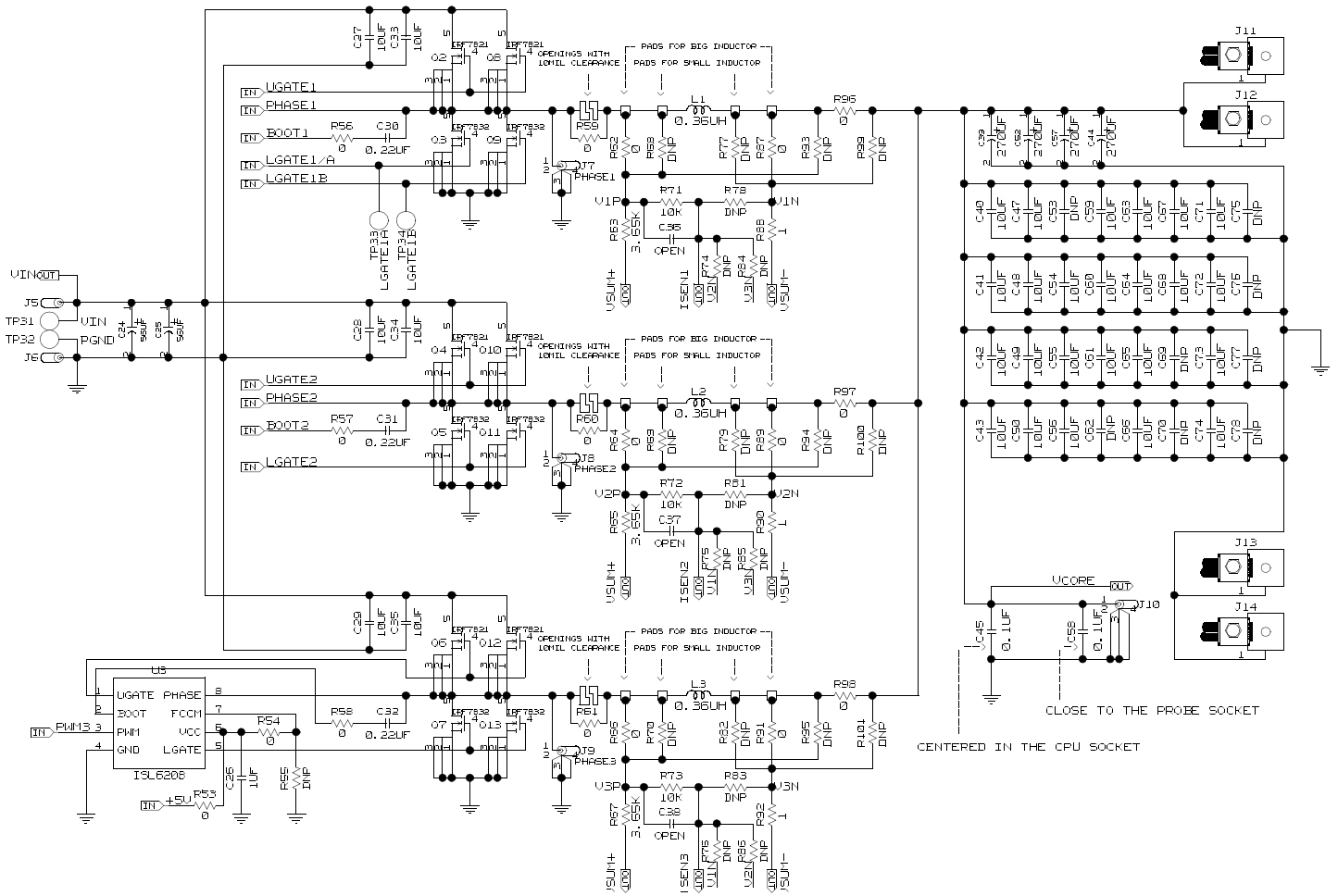

FIGURE 3. ISL62883CEVAL2Z SCHEMATICS, PAGE 2 OF 5





# ISL62883CEVAL2Z Schematic (Continued)

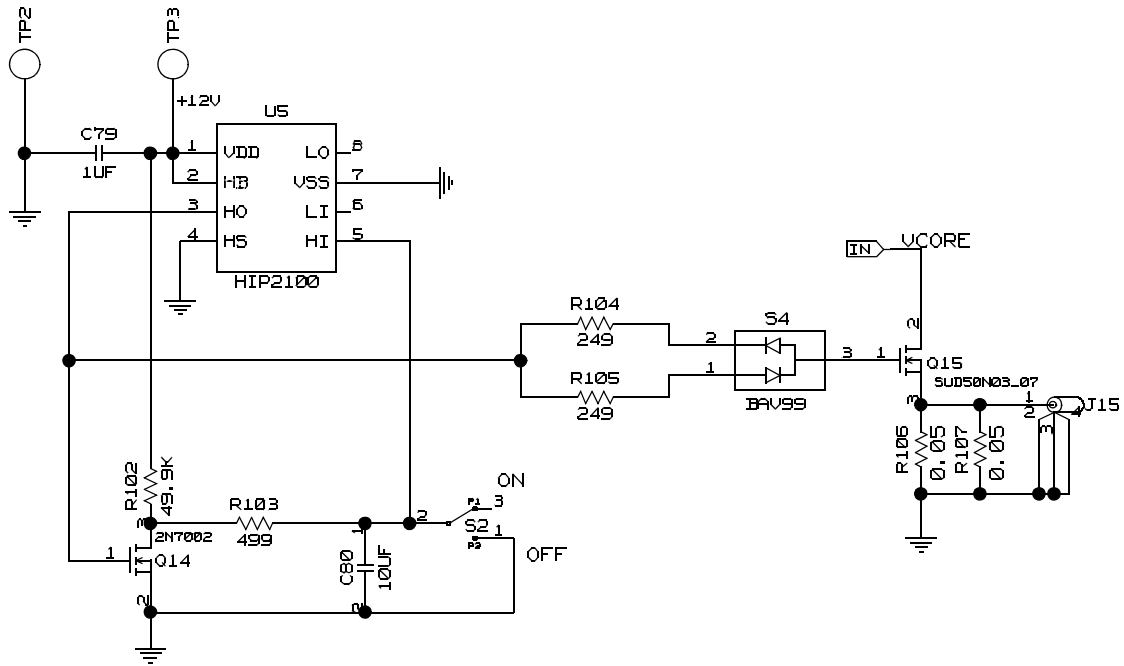

FIGURE 5. ISL62883CEVAL2Z SCHEMATICS, PAGE 4 OF 5

# ISL62883CEVAL2Z Schematic (Continued)

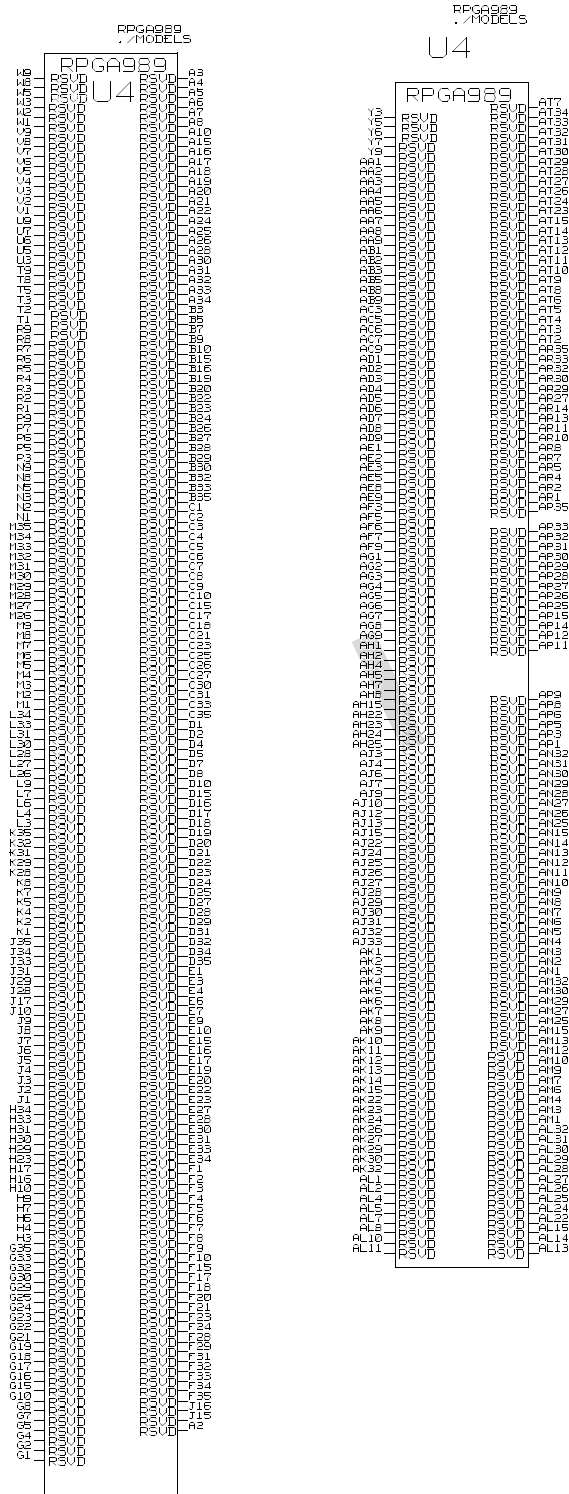

FIGURE 6. ISL62883CEVAL2Z SCHEMATICS, PAGE 5 OF 5

# ISL62883CEVAL2Z Evaluation Board Layout

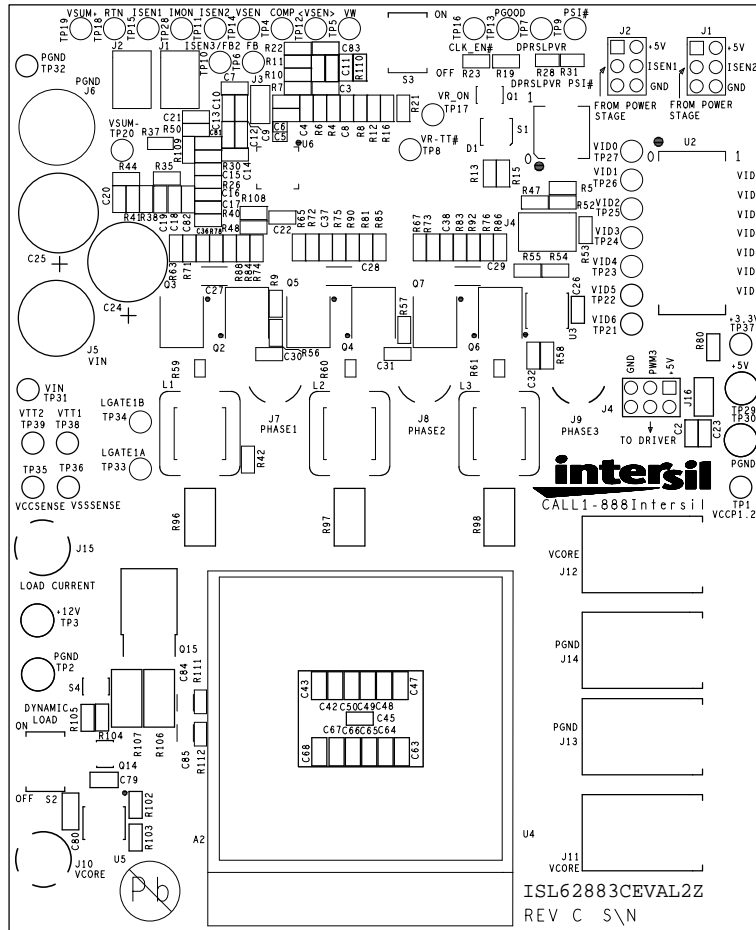

FIGURE 7. TOP SILKSCREEN

# ISL62883CEVAL2Z Evaluation Board Layout (Continued)

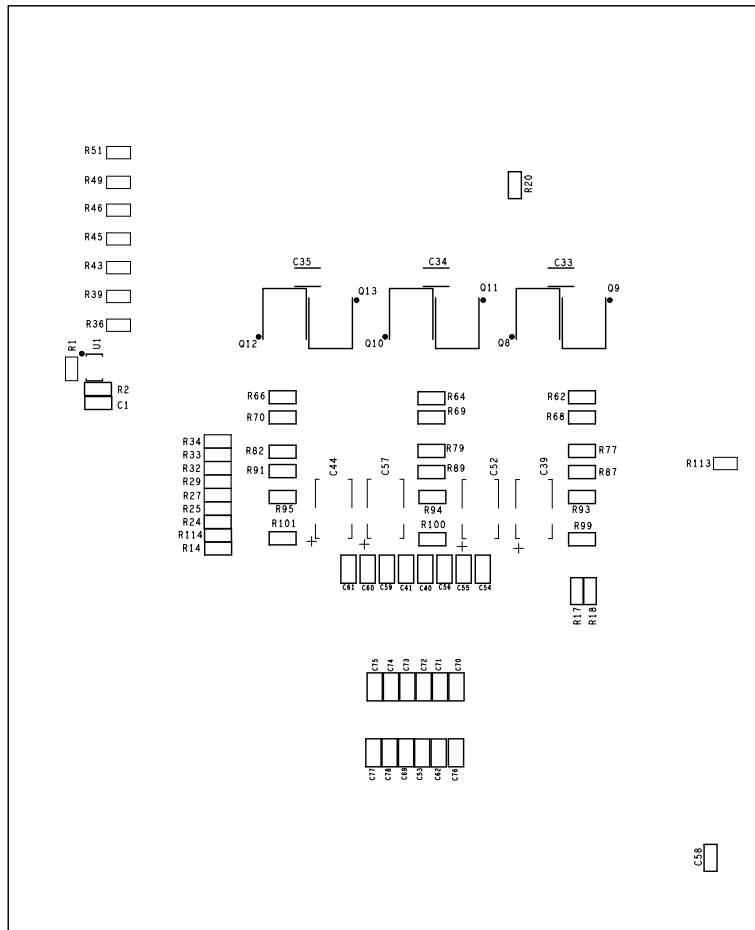

FIGURE 8. BOTTOM SILKSCREEN

# ISL62883CEVAL2Z Evaluation Board Layout (Continued)

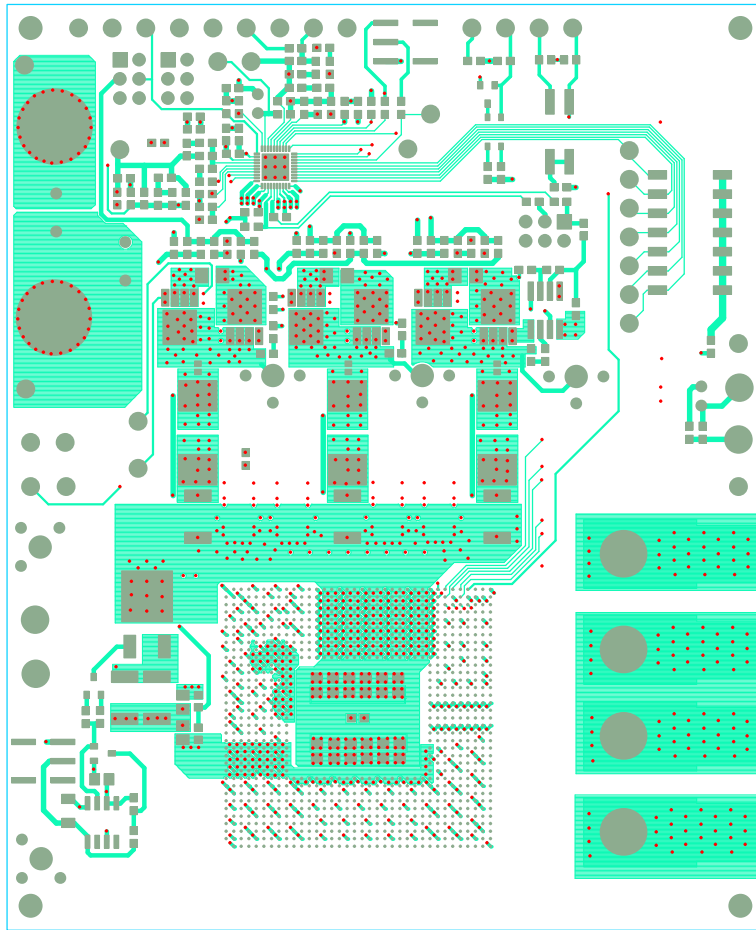

FIGURE 9. LAYER 1

# ISL62883CEVAL2Z Evaluation Board Layout (Continued)

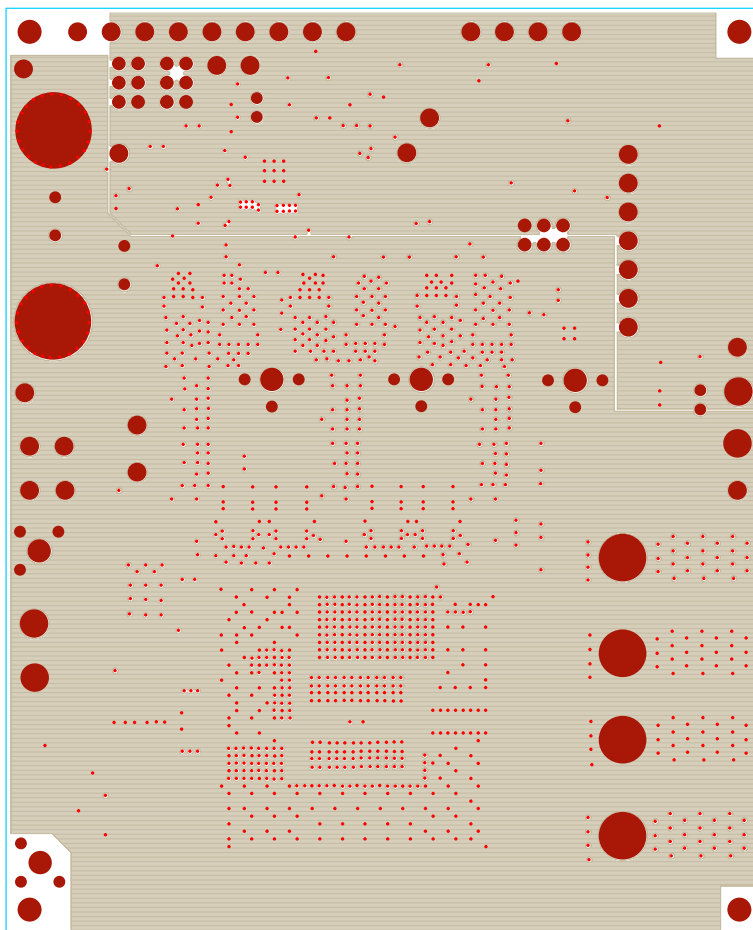

FIGURE 10. LAYER 2

# ISL62883CEVAL2Z Evaluation Board Layout (Continued)

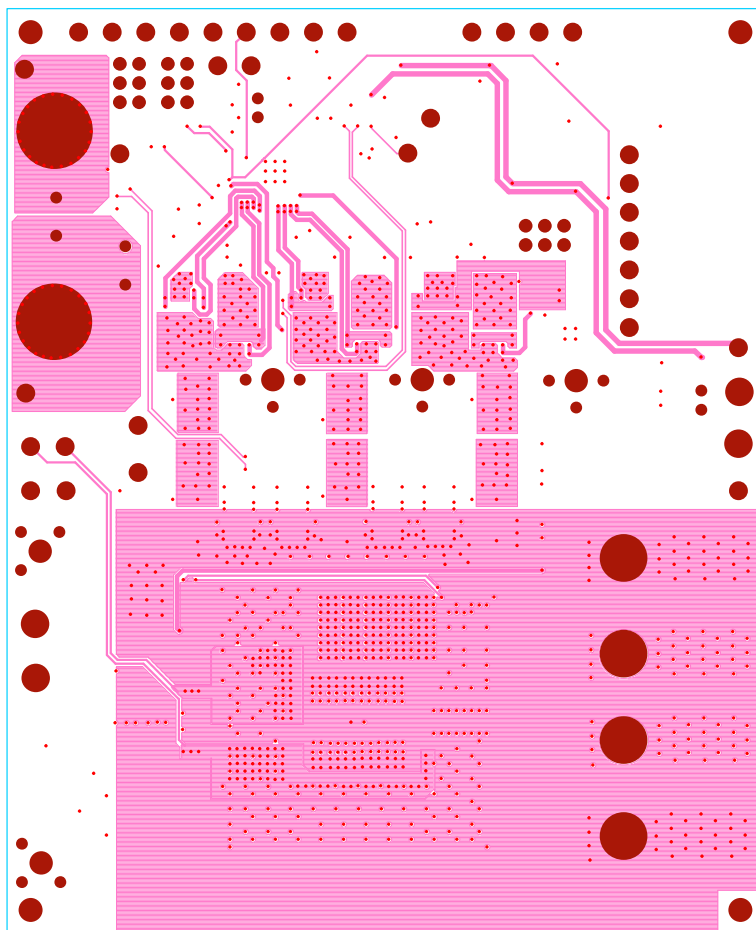

FIGURE 11. LAYER 3

# ISL62883CEVAL2Z Evaluation Board Layout (Continued)

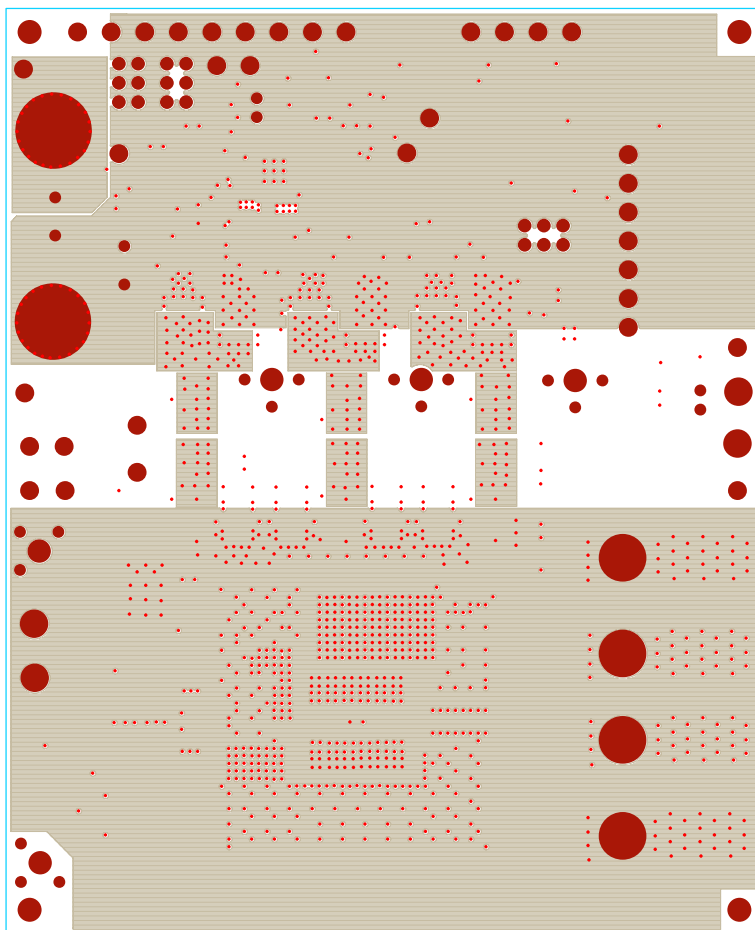

FIGURE 12. LAYER 4



# ISL62883CEVAL2Z Evaluation Board Layout (Continued)

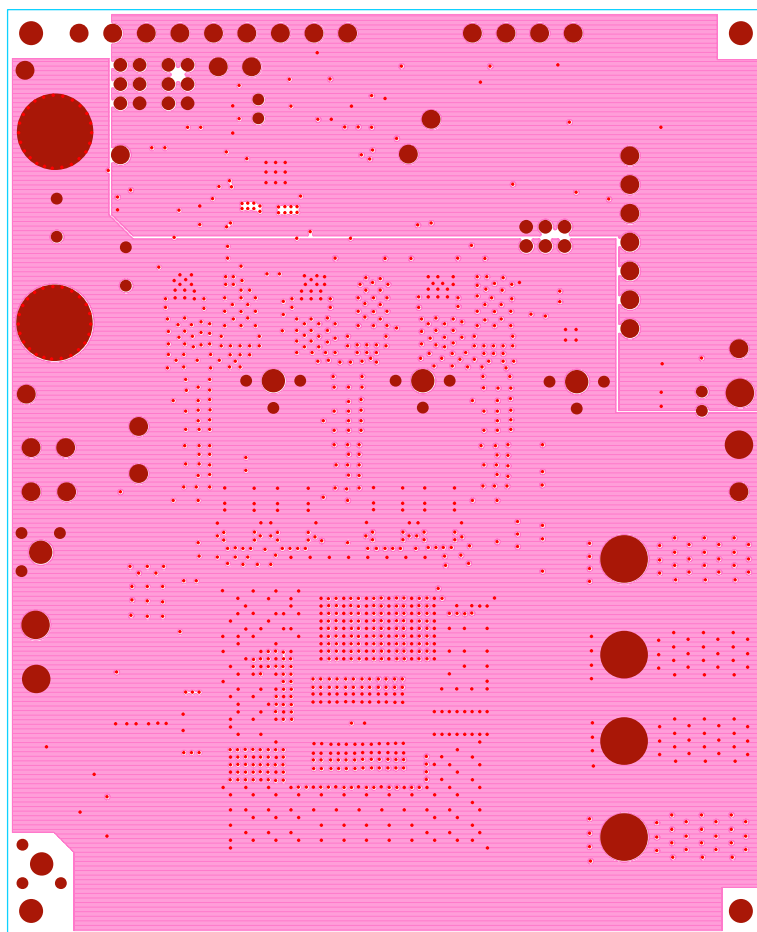

FIGURE 13. LAYER 5

# ISL62883CEVAL2Z Evaluation Board Layout (Continued)

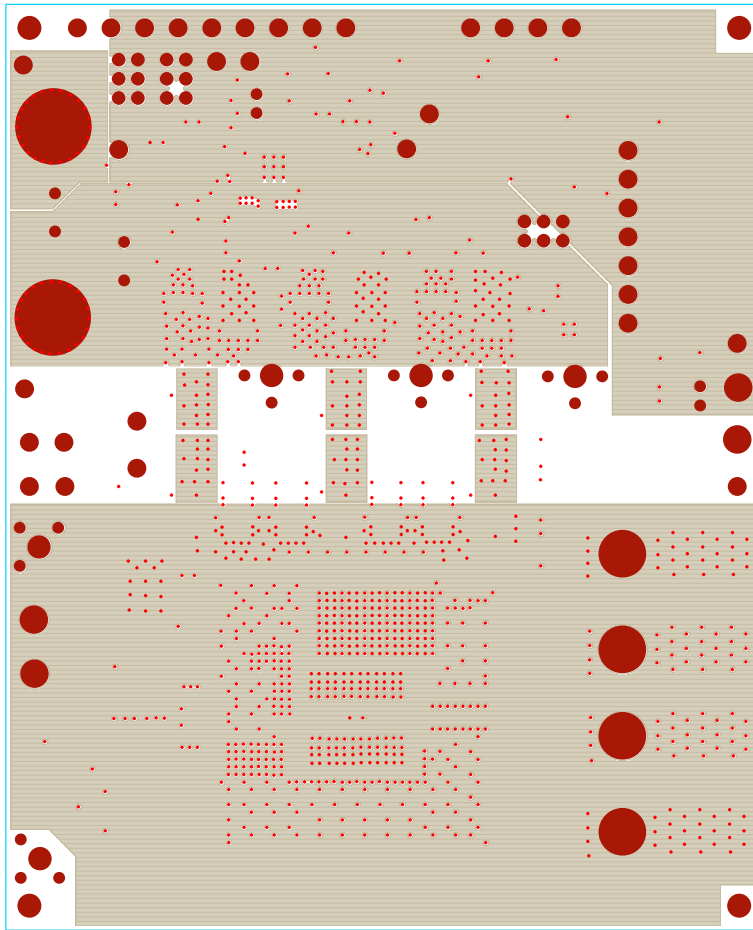

FIGURE 14. LAYER 6

# ISL62883CEVAL2Z Evaluation Board Layout (Continued)

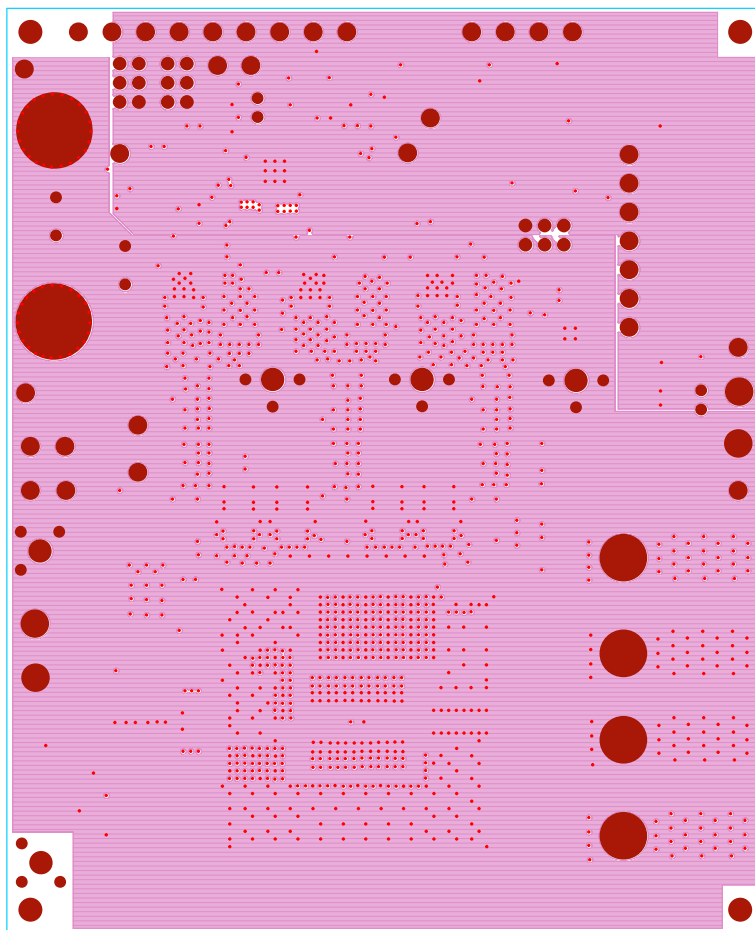

FIGURE 15. LAYER 7

# ISL62883CEVAL2Z Evaluation Board Layout (Continued)

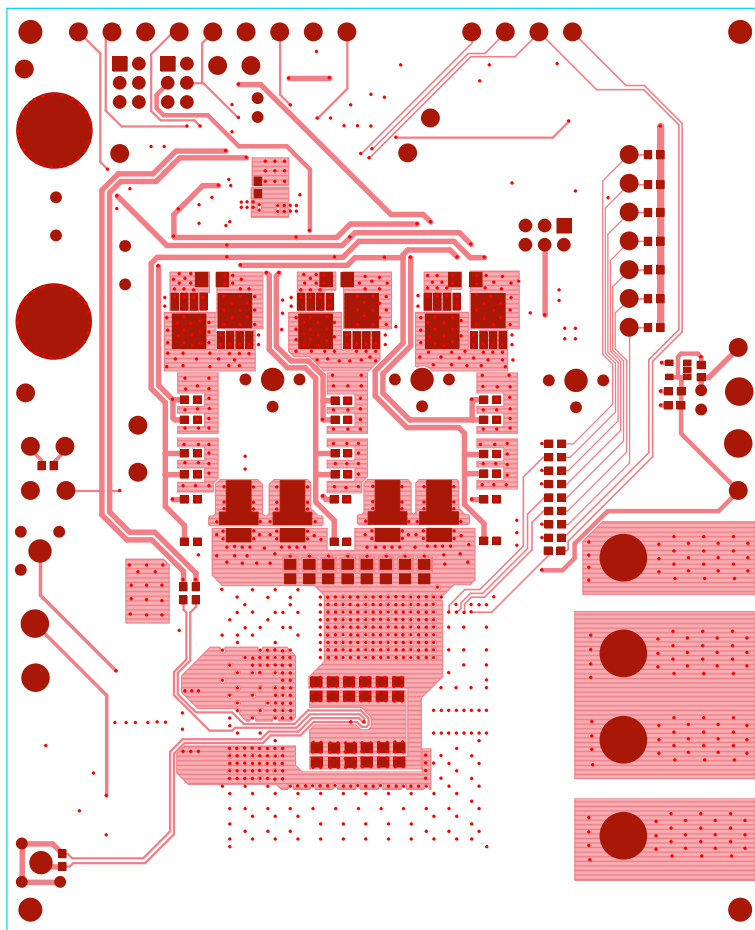

FIGURE 16. LAYER 8