

ISL6294EVAL1Z

Evaluation Board Application Manual

AN1169
Rev 1.00
Nov 28, 2006

Description

The ISL6294EVAL1Z is an evaluation tool for the ISL6294 single-cell Li-Ion battery charger. The evaluation tool provides a complete evaluation platform addressing all datasheet specifications and functionalities. The jumpers on the board facilitate the programming of the charge current, different charging conditions, and can be used to make other necessary connections, such as current measurement.

The ISL6294 is a fully integrated single-cell Li-Ion battery charger that accepts input voltages ranging from 4.5V up to 28V. Since the cradle input is rated for 28V maximum input voltage, the components associated with the input circuit on the evaluation board are good for a 28V supply.

The components assembled in the center square constitute a complete charger, indicating the space saving advantage of the typical ISL6294 installation in space-limited applications.

Ordering Information

PART #	DESCRIPTION
ISL6294EVAL1Z	Evaluation Board for ISL6294

Pinout

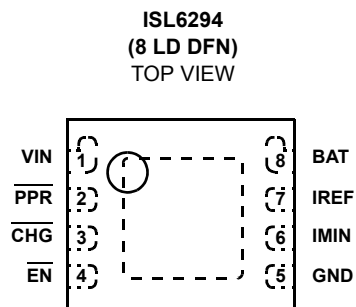

Features

- A Complete Evaluation Platform for the ISL6294 Charger
- The Center Square Suggesting the Space Saving Advantage of the Typical Components Assembly
- Accepts Input Voltage up to 28V
- Flexible Power Connectors Each with a Hook and a Solder Pad Providing Variety to Users
- Convenient Jumpers for Programming the Charge Current, Charge Mode, and for Current Measurement
- 3.5x2.5 Square Inches Board Size Handy for Evaluation
- Six Thermal Vias in the Thermal Pad Similar To Customers' Thermally Enhanced Environment
- On-Board LEDs for Input $\overline{\text{PPR}}$ and $\overline{\text{CHG}}$ State Indication

What is Needed

The following instruments will be needed to perform testing:

- Power supplies:
 - 1) PS1: DC 30V/5A
 - 2) PS2: DC 20V/5A
- DC Electronic load: 20V/5A
- Multimeters
- Function generator
- Oscilloscope
- Cables and wires

Quick Setup Guide (Refer to Figure 1)

DO NOT APPLY POWER UNTIL STEP 5

- Step 1: Connect a 5V supply PS1 to VIN with the current limit set at 1.2A
- Step 2: Connect a 3.7V supply PS2 to VBAT with the current limit set at 1.2A
- Step 3: Connect the DC electronic load of 1.0A to BAT

- Step 4: Verify that jumper shunts JP5 and JP7 are not inserted
- Step 5: Turn on Power Supplies and DC electronic load
- Step 6: The green LED should be on, indicating normal charging operation
- Step 7: The current meter I2 in series with PS2 should read about 0.25A as the charging current
- Step 8: Insert a jumper shunt on JP5 and the current meter I2 should read about 0.5A
- Step 9: Insert a jumper shunt on both JP5 and JP7 and the current meter I2 should read

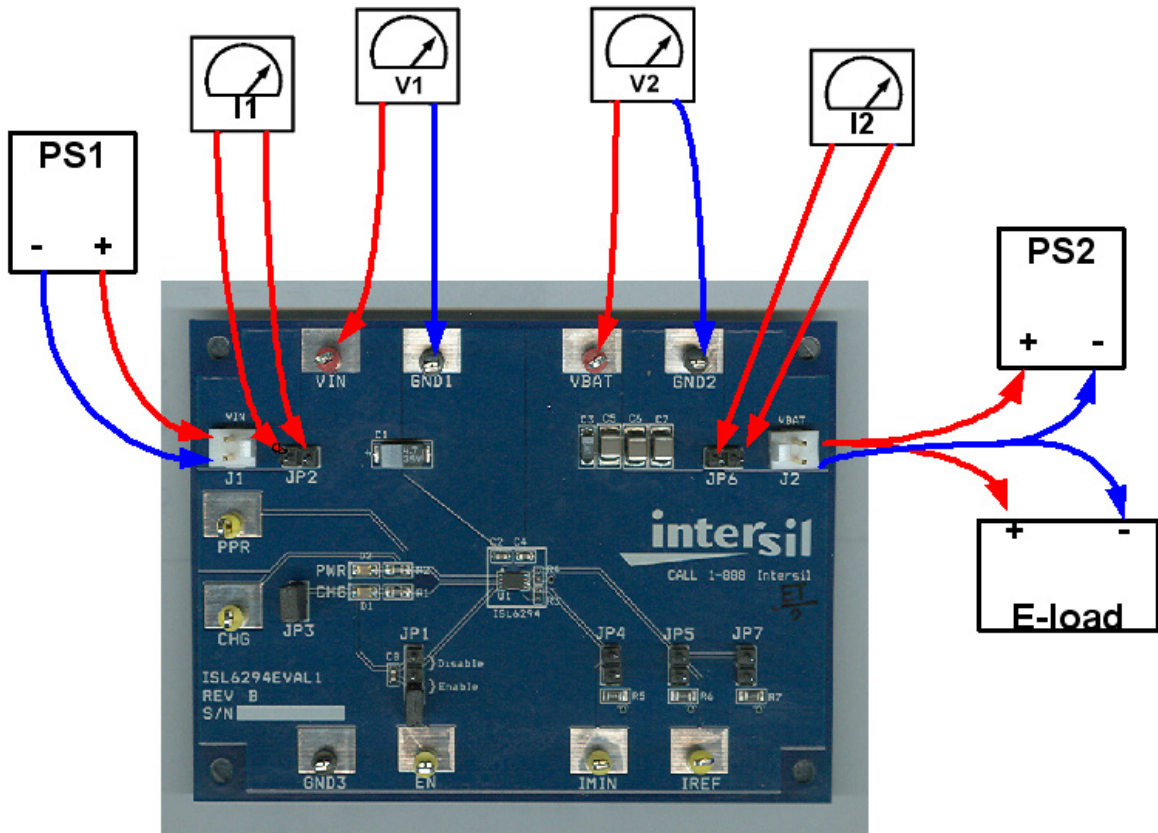

FIGURE 1. CONNECTION OF INSTRUMENTS

Detailed Description

The ISL6294EVAL1Z is a complete evaluation platform addressing all datasheet specifications and functionalities.

The jumpers on the board facilitate the programming of the charge current, different charging conditions, and can be used to make other necessary connections, such as current measurement.

Jumpers

JP1 - Connects the $\overline{\text{EN}}$ pin to a pull-up voltage or GND. The pull-up voltage is either the BAT voltage (When a shunt is installed on JP3) an external 3.3V power source (when the shunt on JP3 is removed and a +3.3V supply is connected to the upper pin of JP3). If there is no shunt installed on JP1, the $\overline{\text{EN}}$ pin is internally pulled down to logic LOW, which enables the charger. If a shunt is installed across the two jumper pins labeled as "Enable", the $\overline{\text{EN}}$ pin is driven to logic LOW, the charger is enabled, same as floating. If the shunt is installed across the two jumper pins labeled as "Disable" and the pull-up voltage is above 2V, the $\overline{\text{EN}}$ pin is driven to logic HIGH, which disables the charger.

JP2 - A shunt installed on JP2 connects the input source from connector J1 to the circuit if input current measurement is not needed. The shunt can be replaced by a current meter if input current measurement is needed.

JP3 - Selects the power source for logic pull-up and the LEDs supply. If a shunt is installed, the BAT voltage is selected as the power source. If the shunt is removed, an external power supply of +3.3V can be connected from the upper pin to GND to provide the pull-up and LEDs supply. This purpose is to exclude the extra current through the charger when characterizing small currents such as EOC and quiescent currents.

JP4 - Parallels an additional 487k resistor to the IMIN pin, such that the End-of-Charge Current will be increased to 43mA (R_{IMIN} is 487k and the EOC current is 20mA without the shunt).

JP5 - Parallels an additional 48.7k resistor to the IREF pin, such that the Cradle charge current will be increased by 0.25A (R_{IREF} is 48.7k and the charge current is 250mA if the shunts on both JP5 and JP7 are removed).

JP6 - A shunt installed on JP6 connects the BAT pin to the output connector J2 if output current measurement is not needed. The shunt can be replaced by a current meter if output current measurement is needed.

JP7 - Parallels an additional 48.7k resistor to the IREF pin, such that the Cradle charge current will be increased by another 0.25A.

TABLE 1. JUMPER SETTINGS

JUMPER	POSITION	FUNCTION
JP1	$\overline{\text{EN}}$ = HIGH	Charger disabled
	$\overline{\text{EN}}$ = GND	Charger enabled
	Shunt not installed	Charger enabled
JP2	Shunt installed	Connect input source to VIN
JP3	Shunt installed	Select BAT as the pull-up source
JP4	Shunt installed	Set EOC current to 43mA
JP5	Shunt installed	Add 0.25A to charging current
JP6	Shunt installed	Connects BAT to J2
JP7	Shunt installed	Add 0.25A to charging current

Board Layout Information

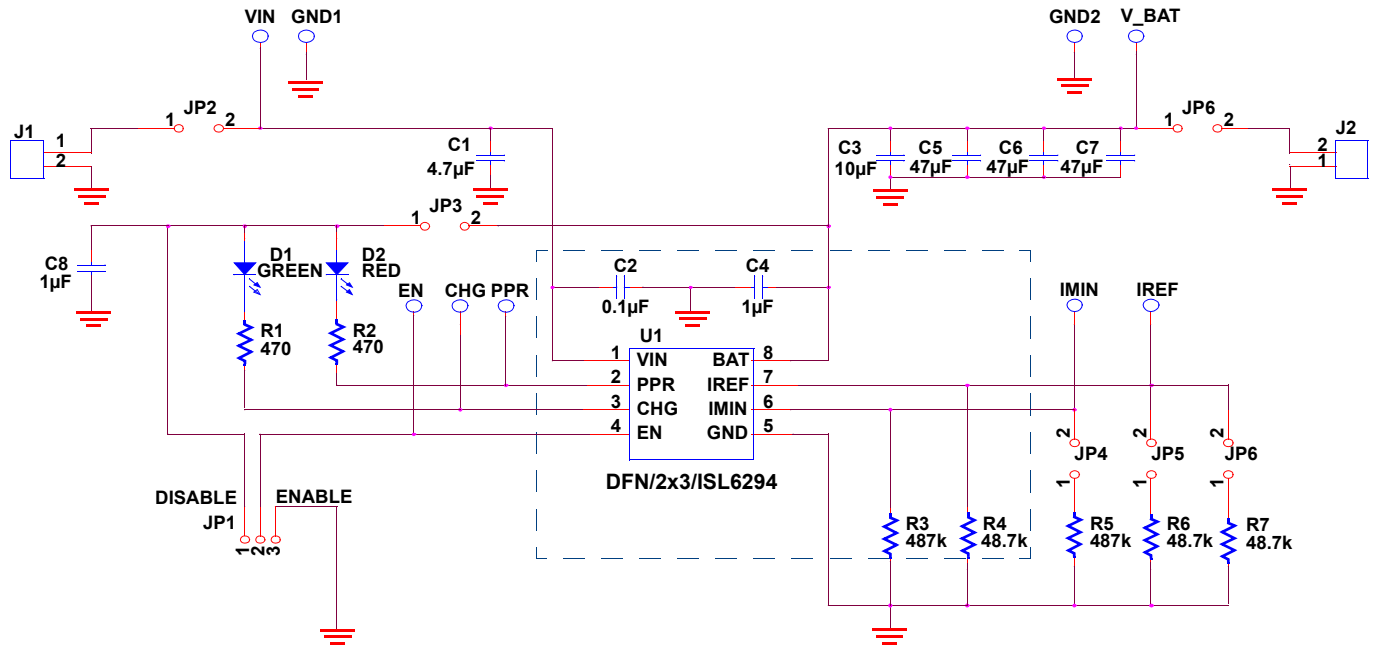
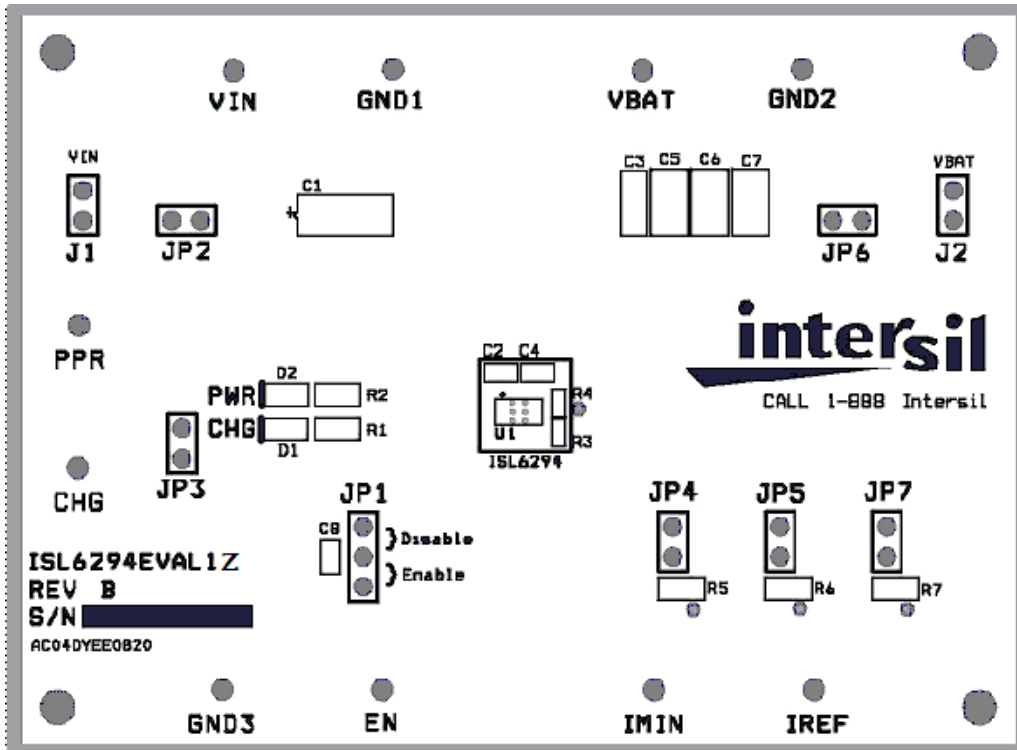

FIGURE 2. SCHEMATIC OF PCB BOARD

TABLE 2. ISL6294EVAL1Z BILL OF MATERIALS (BOM)

ITEM	QTY	REFERENCE	PART DESCRIPTION	PCB FOOTPRINT	PART NUMBER	VENDOR
1	1	U1	ISL6294 Charger	2x3 DFN	ISL6294	Intersil
2	2	R1, R2	470 Ω , 5%, 1/8 Ω Resistor	0805	ERJ-6GEYJ471V	Panasonic
3	1	R3	487k, 1%, 1/16 Ω Resistor	0402	ERJ-2RKF4873X	Panasonic
4	1	R4	48.7k, 1%, 1/16 Ω Resistor	0402	ERJ-2RKF4872X	Panasonic
5	1	R5	487k, 1%, 1/8 Ω Resistor	0805	ERJ-6ENF4873V	Panasonic
6	1	R6	48.7k, 1% 1/8 Ω Resistor	0805	ERJ-6ENF4872V	Panasonic
8	1	C1	4.7 μ F, 35V, Tantalum		ECS-T1VC475R	Panasonic
9	1	C2	0.1 μ F, 50V, X7R Ceramic	0603	C1608X7R1H104K	TDK
10	1	C3	10 μ F, 6.3V, Tantalum	0603	ECS-T0JY106R	Panasonic
11	2	C4, C8	1.0 μ F, 6.3V, X5R Ceramic	0603	ECJ-1VB0J105K	Panasonic
12	3	C5, C6, C7	47 μ F, 6.3V, X5R Ceramic	1210	ECJ-4YB0J476M	Panasonic
13	2	J1, J2	2.54mm Center Header, 2 CKT		22-11-2022	Molex
14	3	VIN, VBAT	Test point, Red		5010	Keystone
15	5	EN, CHG, PPR, IREF, IMIN	Test point, Yellow		5014	Keystone
16	3	GND1, GND2, GND3	Test point, Black		5011	Keystone
17	5	JP2, JP3, JP4, JP5, JP6	2.54mm header, 2 CKT		22-28-4020	Molex
18	2	JP1	2.54mm header, 3 CKT		22-28-4030	Molex
19	1	D1	Green LED	0805	SML-LXT0805GW-TR	Lumex Opto
20	1	D2	Red LED	0805	SML-LXT0805IW-TR	Lumer Opto

PCB Layout



SILK LAYER

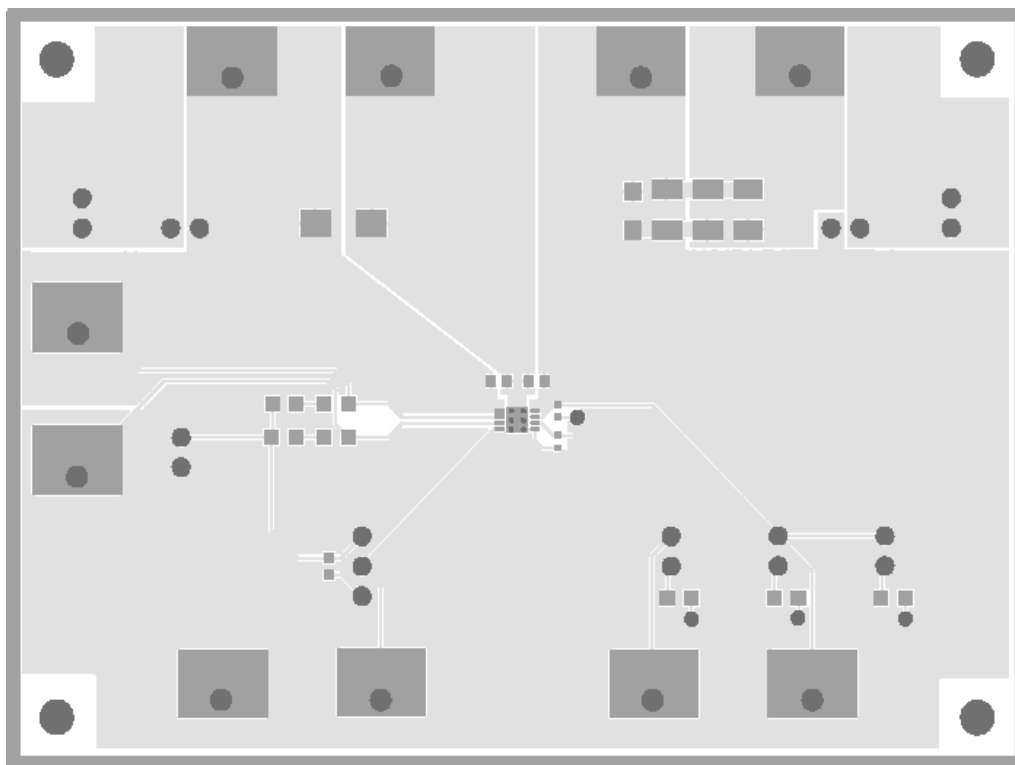

TOP LAYER

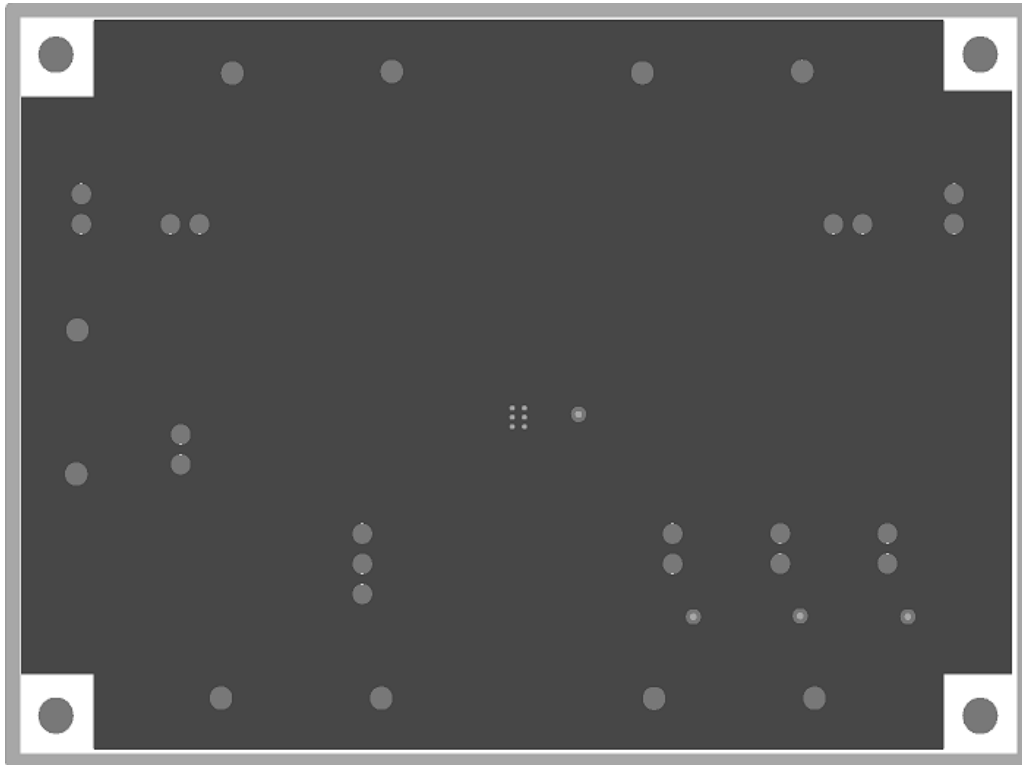

BOTTOM LAYER