

ISL78236CRSHEVAL1Z

Current Share Evaluation Board

AN1928
Rev 0.00
June 17, 2014

Description

The ISL78236CRSHEVAL1Z kit is intended for use by individuals with requirements for Point-of-Load (POL) applications sourcing from 2.85V to 6V. The ISL78236CRSHEVAL1Z evaluation board is used to demonstrate the performance of the ISL78236 low quiescent current mode converter in current sharing configuration. The evaluation board is configured to deliver up to 6A output current with both outputs paralleled together. The ISL78236 can also be used in dual output 3A/3A configuration. For this application, reference ISL78236DUALEVAL1Z [AN1927](#).

The ISL78236 is offered in a 4mmx4mm 24 Ld QFN package with 1mm maximum height. The complete converter occupies less than 5.46cm² area.

Key Features

- Current sharing 6A high efficiency synchronous buck regulator with up to 95% Efficiency
- 180° out-of-phase channel switching
- 2% output accuracy over-temperature/load/line
- Externally adjustable soft-start time
- Soft-stop output discharge during disabled
- External synchronization up to 6MHz
- Typical 8µA shutdown current
- 100% maximum duty cycle for lowest dropout
- External current mode compensation
- Peak current limiting, hiccup mode short circuit protection and over-temperature protection
- Negative current detection and protection

Recommended Equipment

The following materials are recommended to perform testing:

- 5V or higher power supply with at least 6A source current capability or 5V battery
- Electronic loads capable of sinking current up to 7A
- Digital Multimeters (DMMs)
- 100MHz quad-trace oscilloscope
- 10MHz signal generator

Ordering Information

PART NUMBER	DESCRIPTION
ISL78236CRSHEVAL1Z	Current Sharing 6A Synchronous Buck Evaluation Board

Quick Setup Guide

1. Ensure that the evaluation board is correctly connected to the supply and loads prior to applying any power.
2. Connect the bias supply to VIN: The positive terminal to VIN1 and the negative return to PGND1.
3. Verify that switch position is on PWM for S1. Verify that switch position is ON for S2 and S3.
4. Turn on the power supply.
5. Verify the output voltage is 1.8V for V_{OUT1}, V_{OUT2}.

Evaluating Other Output Voltages

The ISL78236CRSHEVAL1Z kit output is preset to 1.8V (V_{OUT1} = V_{OUT2}); however, output voltage can be adjusted from 1.2V to 3.3V. The output voltage programming resistor, RF22, will depend on the desired output voltage of the regulator. The value for the feedback resistor is typically between 50kΩ and 750kΩ, as shown in [Equation 1](#).

Setting RF21 = 100kΩ, then RF22 will be:

$$RF22 = RF21 \left(\frac{V_{OUT}}{0.8} - 1 \right) \quad (EQ. 1)$$

Mode Control

The ISL78236 has a SYNC pin, which connects to logic high or input voltage VIN for internal 2.5MHz switching frequency. Connect the test point by the switch S1 to an external function generator for external synchronization on the negative edge trigger. A 100kΩ pull-up resistor to VIN normally pulls the SYNC pin high. Each channel's switching frequency will be 1/2 of the synchronization frequency at 180° out-of-phase. Synchronization frequency range is 6MHz to 8MHz. Do not leave this pin floating. Do not tie this pin low (or to GND)

Enable Control

EN1 and EN2 pins should be tied together for current sharing operation.

TABLE 1. SWITCH SETTINGS

SWITCH	POSITION	MODE
S1	PFM	DO NOT LEAVE IN THIS POSITION
	PWM	2.5MHz switching frequency if floating. External synchronization switching 6MHz to 8MHz range with generator.
S2/S3	ON	Enable V _{OUT} . Both must be in ON state.
	OFF	Disable V _{OUT} .

ISL78236CRSHEVAL1Z Schematic

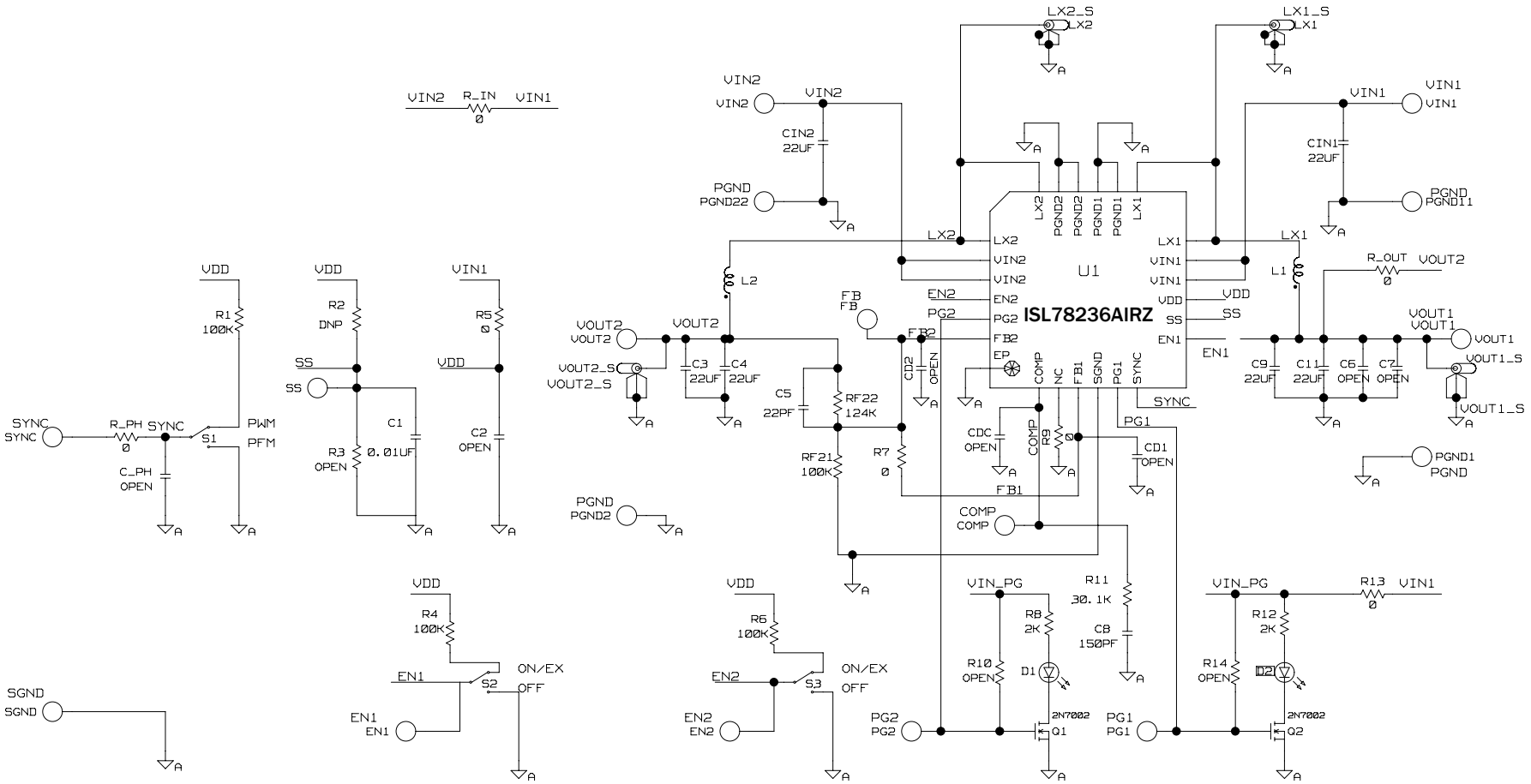

BILL OF MATERIALS

PART NUMBER	QTY	UNITS	REFERENCE DESIGNATOR	DESCRIPTION	MANUFACTURER	MANUFACTURER PART
ISL8033_36EVAL1ZREVAPCB	1	ea.	SEE LABEL-RENAME BOARD	PWB-PCB, ISL8033_36EVAL1Z, REVA, ROHS	TBD	ISL8033_36EVAL1ZREVAPCB
C2012X5R0J226M-T	6	ea.	C3, C4, C9, C11, CIN1, CIN2	CAP, SMD, 0805, 22µF, 6.3V, 20%, X5R, ROHS	TDK	C2012X5R0J226M
H1045-00103-50V5-T	1	ea.	C1	CAP, SMD, 0603, 0.01µF, 50V, 5%, X7R, ROHS	VENKEL	C0603X7R500-103JNE
					KEMET	C0603C103J5RACTU
					AVX	06035C103JAT2A
					TDK	C1608X7R1H103J
H1045-00151-50V5-T	1	ea.	C8	CAP, SMD, 0603, 150pF, 50V, 5%, NPO, ROHS	PANASONIC VENKEL	ECJ-1VC1H151J C0603C0G500-151JNE
H1045-00220-50V5-T	1	ea.	C5	CAP, SMD, 0603, 22pF, 50V, 5%, COG, ROHS	VENKEL	C0603C0G500-220JNE
					KEMET	C0603C220J5GACTU
					TDK	C1608C0G1H220J
					MURATA	GRM1885C1H220JA01D
					ROHM	MCH185A220JK
H1045-DNP	0	ea.	C2, C10, CD1, CD2, CDC, C_PH	CAP, SMD, 0603, DNP-PLACE HOLDER, ROHS		
H1046-DNP	0	ea.	C6, C7	CAP, SMD, 0805, DNP-PLACE HOLDER, ROHS		
FDV0630-R60M	2	ea.	L1, L2	COIL-PWR INDUCTOR, SMD, 7.4X6.7, 0.6µH, 20%, ROHS	TOKO	FDV0630-R60M
131-4353-00	4	ea.	LX1, LX2, VOUT1_S, VOUT2_S	CONN-SCOPE PROBE TEST PT, COMPACT, PCB MNT, ROHS	TEKTRONIX	131-4353-00
1514-2	8	ea.	a) PGND1, PGND2, PGND11, PGND22, VIN1, VIN2	CONN-TURRET, TERMINAL POST, TH, ROHS	KEYSTONE	1514-2
1514-2	0	ea.	b) VOUT1, VOUT2	CONN-TURRET, TERMINAL POST, TH, ROHS	KEYSTONE	1514-2
5000	6	ea.	a) EN1, EN2, PG1, PG2, SS, SYNC	CONN-MINI TEST PT, VERTICAL, RED, ROHS	KEYSTONE	5000
5000	0	ea.	b) SYNC located left of C_PH	CONN-MINI TEST PT, VERTICAL, RED, ROHS	KEYSTONE	5000
5001	1	ea.	SGND	CONN-MINI TEST PT, VERTICAL, BLK, ROHS	KEYSTONE	5001
5002	2	ea.	COMP, FB	CONN-MINI TEST POINT, VERTICAL, WHITE, ROHS	KEYSTONE	5002
LTST-C170CKT	2	ea.	D1, D2	LED-GaAs RED, SMD, 2mmX1.25mm, 100mW, 40mA, 10mcd, ROHS	LITEON/VISHAY	LTST-C170CKT
					ROHM	SML-210LTT86
					STANLEY ELECTRIC	BR112H-TR
ISL78236IRZ	1	ea.	U1	IC-DUAL 3A CONTROLLER, 2.5MHz, 24P, QFN,4X4, ROHS	INTERSIL	ISL78236IRZ
2N7002-7-F-T	2	ea.	Q1, Q2	TRANSISTOR,N-CHANNEL, 3 LD, SOT-23, 60V, 115mA, ROHS	DIODES, INC.	2N7002-7-F
					ON SEMICONDUCTOR	2N7002LT1G

BILL OF MATERIALS (Continued)

PART NUMBER	QTY	UNITS	REFERENCE DESIGNATOR	DESCRIPTION	MANUFACTURER	MANUFACTURER PART
H2509-00R00-1/20W-T	1	ea.	R9	RESISTOR, SMD, 0201, 0Ω, 1/20W, 0%, TF	PANASONIC	H2509-00R00-1/20W-T
H2511-00R00-1/10W-T	4	ea.	R7, R5, R13, R_PH	RES, SMD, 0603, 0Ω, 1/10W, TF, ROHS	VENKEL	CR0603-10W-000T
					ROHM	MCR03EZPJ000
					PANASONIC	ERJ-3GEY0R00V
					YAGEO	RC0603JR-070RL
					VISHAY/DALE	CRCW06030000Z0EA
H2511-01003-1/10W1-T	3	ea.	R1, R4, R6	RES, SMD, 0603, 100k, 1/10W, 1%, TF, ROHS	VENKEL	CR0603-10W-1003FT
					PANASONIC	ERJ-3EKF1003V
					ROHM	MCR03EZPFX1003
					YAGEO	RC0603FR-07100KL
					STACKPOLE	RMCF 1/16 100K 1% R
H2511-01003-1/10W1-T	1	ea.	RF21	RES, SMD, 0603, 100k, 1/10W, 1%, TF, ROHS	VENKEL	CR0603-10W-1003FT
					PANASONIC	ERJ-3EKF1003V
					ROHM	MCR03EZPFX1003
					YAGEO	RC0603FR-07100KL
					STACKPOLE	RMCF 1/16 100K 1% R
H2511-01243-1/10W1-T	1	ea.	RF22	RES, SMD, 0603, 124k, 1/10W, 1%, TF, ROHS	YAGEO	9C06031A1243FKHFT
					PANASONIC	ERJ-3EK1243V
H2511-02001-1/10W1-T	2	ea.	R8, R12	RES, SMD, 0603, 2k, 1/10W, 1%, TF, ROHS	KOA VENKEL	RK73H1JTTD2001F CR0603-10W-2001FT
H2511-03012-1/10W1-T	1	ea.	R11	RESISTOR, SMD, 0603, 30.1k, 1/10W, 1%, TF, ROHS	VENKEL	CR0603-10W-3012FT
					YAGEO	RC0603FR-0730K1L
H2511-DNP	0	ea.	R2, R3, R10, R14, RF11, RF12	RES, SMD, 0603, DNP-PLACE HOLDER, ROHS		
H2514-00R00-1/4W-T	2	ea.	R_IN, R_OUT	RES, SMD, 1210, 0Ω, 1/4W, TF, ROHS	VENKEL	CR1210-4W-000
GT11MSCBE-T	3	ea.	S1-S3	SWITCH-TOGGLE, SMD, 6 PIN, SPDT, 2POS, ON-ON, ROHS	ITT INDUSTRIES/ C&K DIVISION	GT11MSCBE
SJ-5003-BLACK	4	ea.	Bottom four corners	BUMPONS, 0.44"Wx0.20"H, DOMETOP, BLACK	3M	SJ-5003SPBL
5X8-STATIC-BAG	1	ea.	Place assy in bag	BAG, STATIC, 5x8, ZIPLOC, ROHS	INTERSIL	212403-013
LABEL-RENAME BOARD	1	ea.	RENAME PCB TO: ISL78236CRSHEVAL1Z	LABEL, TO RENAME BOARD	INTERSIL	LABEL-RENAME BOARD
LABEL-SERIAL NUMBER	1	ea.		LABEL-FOR SERIAL NUMBER AND BOM REV #	INTERSIL	LABEL-SERIAL NUMBER

ISL78236CRSHEVAL1Z Board Layout

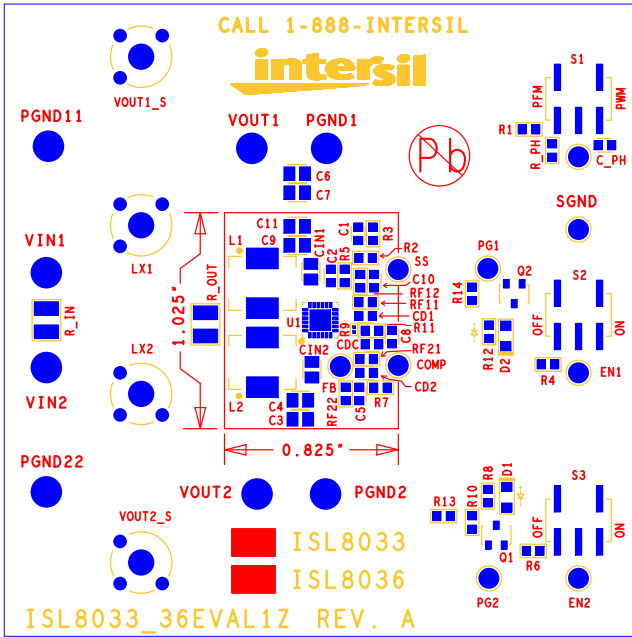

FIGURE 1. TOP COMPONENTS

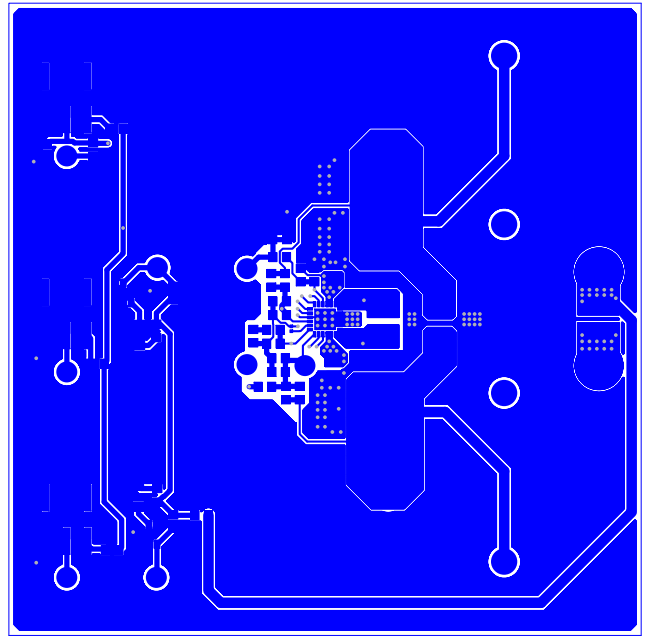

FIGURE 2. TOP LAYER ETCH

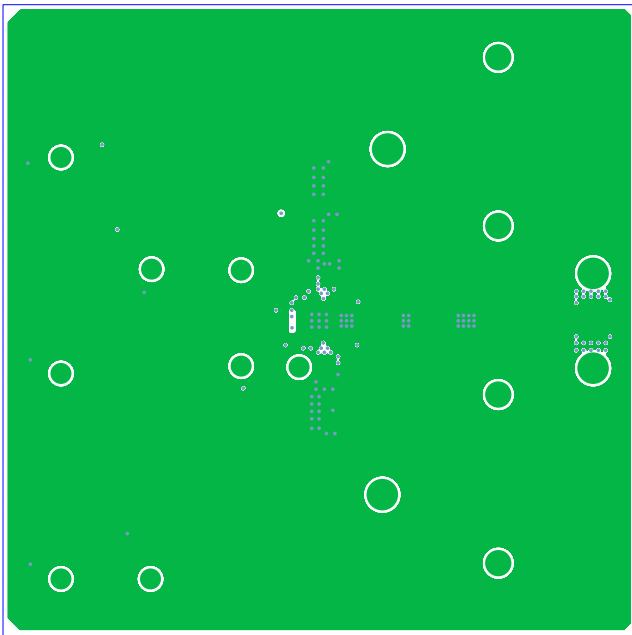

FIGURE 3. 2ND LAYER ETCH

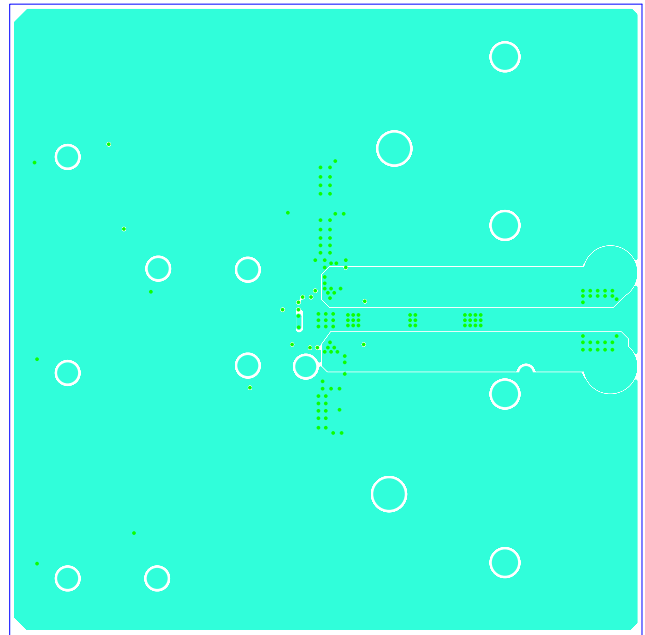

FIGURE 4. 3RD LAYER ETCH

ISL78236CRSHEVAL1Z Board Layout (Continued)

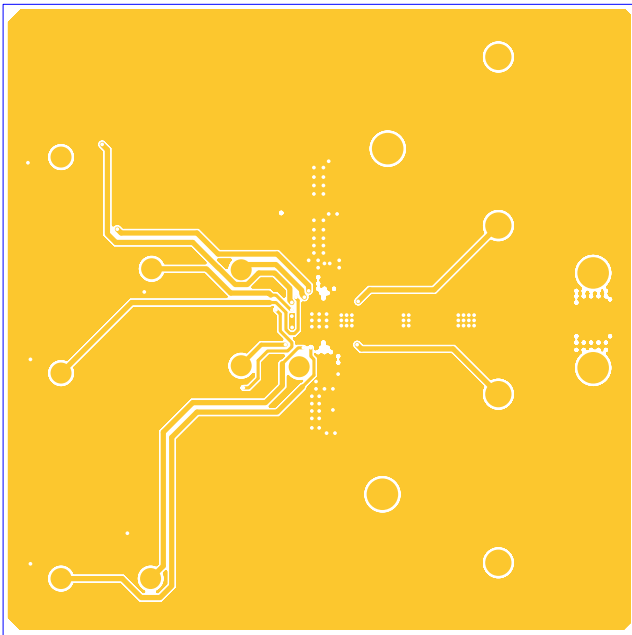

FIGURE 5. BOTTOM LAYER ETCH

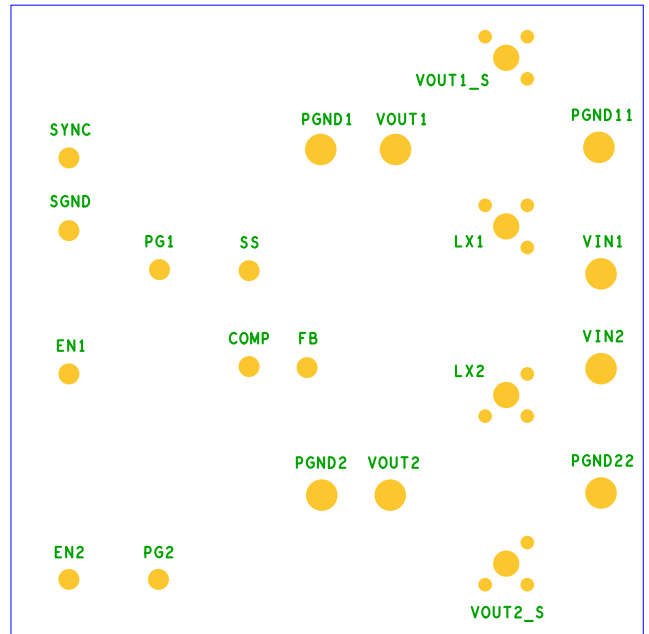

FIGURE 6. BOTTOM COMPONENTS (MIRROR)