

## ISL78236DUALEVAL1Z

Dual Output Evaluation Board

AN1927  
Rev 0.00  
June 17, 2014

### Description

The ISL78236DUALEVAL1Z kit is intended for use by individuals with requirements for Point-of-Load (POL) applications sourcing from 2.85V to 6V. The ISL78236DUALEVAL1Z evaluation board is used to demonstrate the performance of the ISL78236 low quiescent current mode converter. The evaluation board is configured to deliver up to 3A output current on each of the two output channels. The ISL78236 can be configured in a current share mode for a single 6A output current. For this application, reference ISL78236CRSHEVAL1Z [AN1928](#).

The ISL78236 is offered in a 4mmx4mm 24 Ld QFN package with 1mm maximum height. The complete converter occupies less than 5.46cm<sup>2</sup> area.

### Key Features

- Dual 3A high efficiency synchronous buck regulator with up to 95% efficiency
- 180° out-of-phase channel switching
- 2% output accuracy over-temperature/load/line
- Internal digital soft-start - 1.5ms
- Soft-stop output discharge during disable
- Typical 8µA shutdown current
- 100% maximum duty cycle for lowest dropout
- Internal current mode compensation
- Peak current limiting, hiccup mode short circuit protection and over-temperature protection
- Negative current detection and protection

### Recommended Equipment

The following equipment is recommended to perform evaluation of this board:

- 5V or higher power supply with at least 6A source current capability or 5V battery
- Electronic loads capable of sinking current up to 3A
- Digital Multimeters (DMMs)
- 100MHz quad-trace oscilloscope
- 10MHz signal generator

### Ordering Information

PART NUMBER	DESCRIPTION
ISL78236DUALEVAL1Z	Dual Output 3A/3A Synchronous Buck Evaluation Board

### Quick Setup Guide

1. Ensure that the evaluation board is correctly connected to the supply and loads prior to applying any power.
2. Connect the bias supply to VIN: The positive terminal to VIN1 and the negative return to PGND1.
3. Verify that switch position is on PWM for S1. Verify that switch position is ON for S2 and S3.
4. Turn on the power supply.
5. Verify the output voltage is 1.8V for both channels.

### Evaluating Other Output Voltages

The ISL78236DUALEVAL1Z kit outputs are preset to 1.8V for V<sub>OUT1</sub> and 1.8V for V<sub>OUT2</sub>; however, output voltages can be adjusted from 1.2V to 3.3V. The output voltage programming resistor, RF12 (or RF22 in Channel 2), will depend on the desired output voltage of the regulator. The value for the feedback resistor (RF12 and RF22) is typically between 50kΩ and 750kΩ, as shown in [Equations 1](#) and [2](#).

Setting RF11 and RF21 = 100kΩ, then RF12 and RF22 will be:

$$RF12 = RF11 \left( \frac{V_{OUT1}}{0.8} - 1 \right) \quad (EQ. 1)$$

$$RF22 = RF21 \left( \frac{V_{OUT2}}{0.8} - 1 \right) \quad (EQ. 2)$$

### SYNC Mode Control

The ISL78236 has a SYNC pin, which connects to logic high or input voltage VIN for internal 2.5MHz switching frequency. Connect the test point by the switch S1 to an external function generator for external synchronization on the negative edge trigger. A 100kΩ pull-up resistor to VIN normally pulls the SYNC pin high. Each channel's switching frequency will be 1/2 of the synchronization frequency at 180° out-of-phase. Synchronization frequency range is 6MHz to 8MHz. Do not leave this pin floating. Do not tie this pin low (or to GND).

TABLE 1. SWITCH SETTINGS

SWITCH	POSITION	MODE
S1	PFM	DO NOT LEAVE IN THIS POSITION
	PWM	2.5MHz switching frequency if floating. External synchronization switching 6MHz to 8MHz range with generator.
S2	ON	Enable VOUT1
	OFF	Disable VOUT1
S3	ON	Enable VOUT2
	OFF	Disable VOUT2

# ISL78236DUALEVAL1Z Schematic

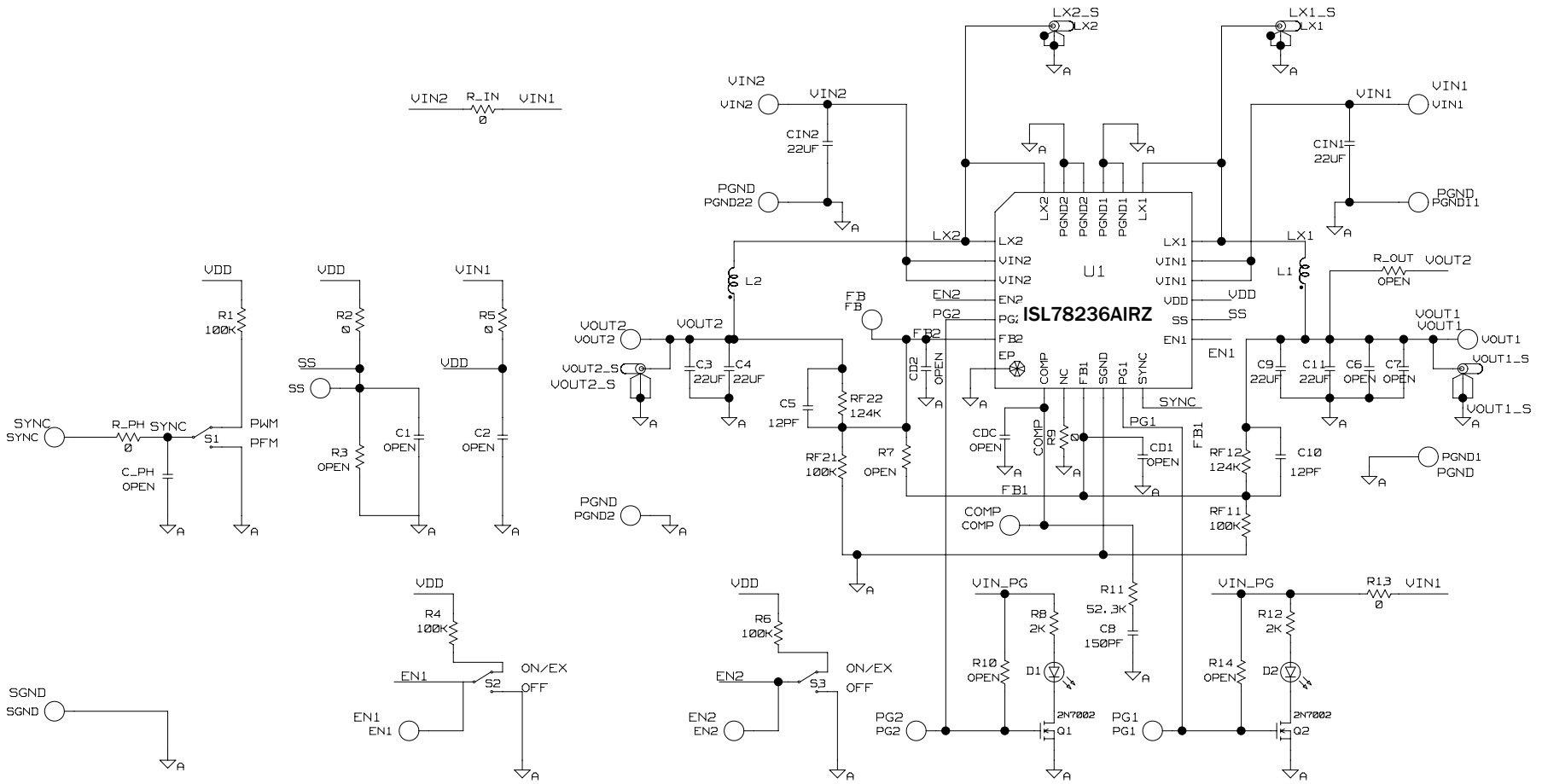

# Bill of Materials

PART NUMBER	QTY	UNITS	REFERENCE DESIGNATOR	DESCRIPTION	MANUFACTURER	MANUFACTURER PART
ISL8033_36EVAL1ZREVAPCB	1	ea.	a) PUT "X" IN ISL8036 BOX ON PCB	PWB-PCB, ISL8033_36EVAL1Z, REVA, ROHS	IMAGINEERING INC.	ISL8033_36EVAL1ZREVAPCB
ISL8033_36EVAL1ZREVAPCB	0	ea.	b) SEE LABEL-RENAME BOARD	PWB-PCB, ISL8033_36EVAL1Z, REVA, ROHS	IMAGINEERING INC.	ISL8033_36EVAL1ZREVAPCB
C2012X5R0J226M-T	6	ea.	C3, C4, C9, C11, CIN1, CIN2	CAP, SMD, 0805, 22µF, 6.3V, 20%, X5R, ROHS	TDK	C2012X5R0J226M
H1045-00120-50V5-T	2	ea.	C5, C10	CAP, SMD, 0603, 12pF, 50V, 5%, COG, ROHS	AVX	06035A120JAT2A
H1045-00151-50V5-T	1		C8	CAP, SMD, 0603, 150pF, 50V, 5%, NPO, ROHS	PANASONIC	ECJ-1VC1H151J
H1045-DNP	0	ea.	C1, C2, C8, CD1, CD2, CDC, C_PH	CAP, SMD, 0603, DNP-PLACE HOLDER, ROHS		
H1046-DNP	0	ea.	C6, C7	CAP, SMD, 0805, DNP-PLACE HOLDER, ROHS		
FDV0630-R60M	2	ea.	L1, L2	COIL-PWR INDUCTOR, SMD, 7.4X6.7, 0.6µH, 20%, ROHS	TOKO	FDV0630-R60M
131-4353-00	4	ea.	LX1, LX2, VOUT1_S, VOUT2_S	CONN-SCOPE PROBE TEST PT, COMPACT, PCB MNT, ROHS	TEKTRONIX	131-4353-00
1514-2	8	ea.	a) PGND1, PGND2, PGND11, PGND22, VIN1, VIN2	CONN-TURRET, TERMINAL POST, TH, ROHS	KEYSTONE	1514-2
1514-2	0	ea.	b) VOUT1, VOUT2	CONN-TURRET, TERMINAL POST, TH, ROHS	KEYSTONE	1514-2
5000	6	ea.	a) EN1, EN2, PG1, PG2, SS, SYNC	CONN-MINI TEST PT, VERTICAL, RED, ROHS	KEYSTONE	5000
5000	0	ea.	b) SYNC located left of C_PH	CONN-MINI TEST PT, VERTICAL, RED, ROHS	KEYSTONE	5000
5001	1	ea.	SGND	CONN-MINI TEST PT, VERTICAL, BLK, ROHS	KEYSTONE	5001
5002	2	ea.	COMP, FB	CONN-MINI TEST PT, VERTICAL, WHITE, ROHS	KEYSTONE	5002
LTST-C170CKT	2	ea.	D1, D2	LED-GaAs RED, SMD, 2mmX1.25mm, 100mW, 40mA, 10mcd, ROHS	LITEON/VISHAY	LTST-C170CKT
ISL78236IRZ	1	ea.	U1	IC-DUAL 3A BUCK REGULATOR, 2.5MHz, 24P, QFN, 4X4, ROHS	INTERSIL	ISL78236IRZ
2N7002-7-F-T	2	ea.	Q1, Q2	TRANSISTOR, N-CHANNEL, 3 LD, SOT-23, 60V, 115mA, ROHS	DIODES, INC.	2N7002-7-F
H2509-DNP	1	ea.	R9	RES, SMD, 0201, 0Ω, 1/20W, 0%, TF	PANASONIC	H2509-00R00-1/20W-T
H2511-00R00-1/10W-T	4	ea.	R2, R5, R13, R_PH	RES, SMD, 0603, 0Ω, 1/10W, TF, ROHS	VENKEL	CR0603-10W-000T

**Bill of Materials (Continued)**

PART NUMBER	QTY	UNITS	REFERENCE DESIGNATOR	DESCRIPTION	MANUFACTURER	MANUFACTURER PART
H2511-01003-1/10W1-T	5	ea.	R1, R4, R6, RF11, RF21	RES, SMD, 0603, 100k, 1/10W, 1%, TF, ROHS		
H2511-01243-1/10W1-T	2	ea.	RF12, RF22	RES, SMD, 0603, 124k, 1/10W, 1%, TF, ROHS	YAGEO	9C06031A1243FKHFT
H2511-02001-1/10W1-T	2	ea.	R8, R12	RES, SMD, 0603, 2k, 1/10W, 1%, TF, ROHS	KOA	RK73H1JTTD2001F
H2511-05232-1/10W1-T	1	ea.	R11	RES, SMD, 0603, 52.3k, 1/10W, 1%, TF, ROHS	VENKEL	CR0603-10W-5232FT
H2511-DNP	0	ea.	R3, R7, R10, R14	RES, SMD, 0603, DNP-PLACE HOLDER, ROHS		
H2514-00R00-1/4W-T	1	ea.	R_IN	RES, SMD, 1210, 0Ω, 1/4W, TF, ROHS	VENKEL	CR1210-4W-000
H2514-DNP	0	ea.	R_OUT	RES, SMD, 1210, DNP, DNP, DNP, TF, ROHS		
GT11MSCBE-T	3	ea.	S1-S3	SWITCH-TOGGLE, SMD, 6 PIN, SPDT, 2POS, ON-ON, ROHS	ITT INDUSTRIES/C&K DIVISION	GT11MSCBE
SJ-5003-BLACK	4	ea.	Bottom four corners	BUMPONS, 0.44"Wx0.20"H, DOMETOP, BLACK	3M	SJ-5003SPBL
5X8-STATIC-BAG	1	ea.	Place assy in bag	BAG, STATIC, 5X8, ZIP LOC	INTERSIL	212403-013
LABEL-RENAME BOARD	1	ea.	RENAME PCB TO: ISL78236DUALEVAL1Z	LABEL, TO RENAME BOARD	INTERSIL	LABEL-RENAME BOARD
LABEL-SERIAL NUMBER	1	ea.		LABEL, FOR SERIAL NUMBER AND BOM REV #		

# ISL78236DUALEVAL1Z Board Layout

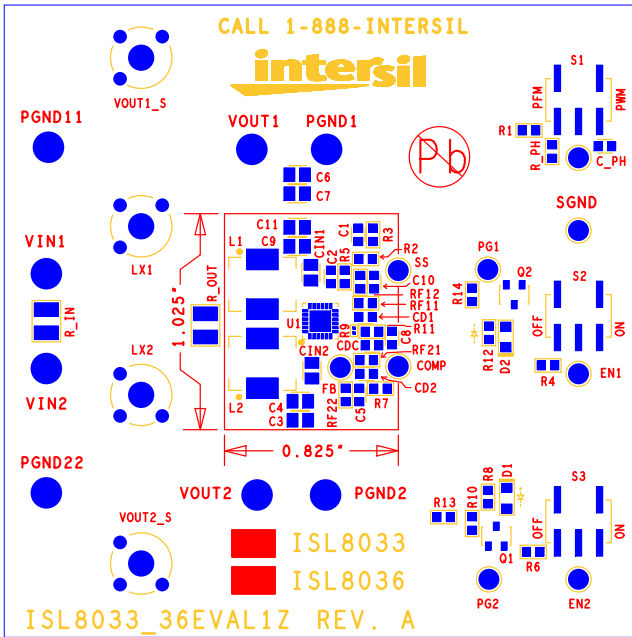

FIGURE 1. TOP COMPONENTS

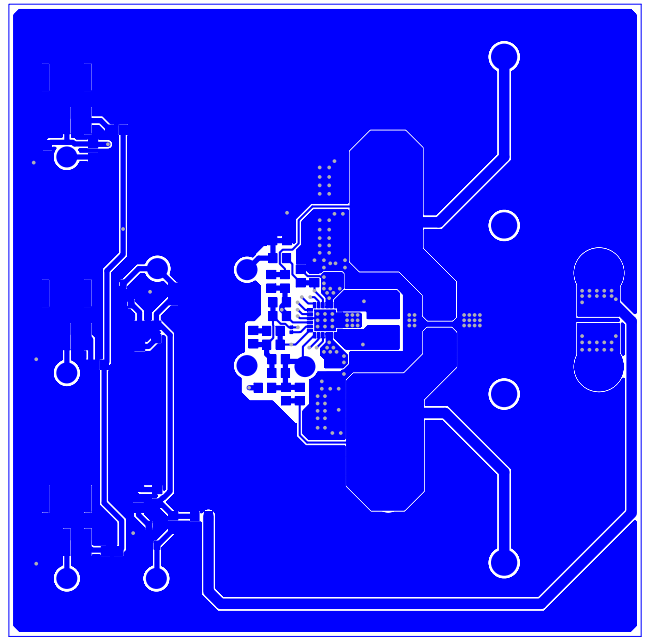

FIGURE 2. TOP LAYER ETCH

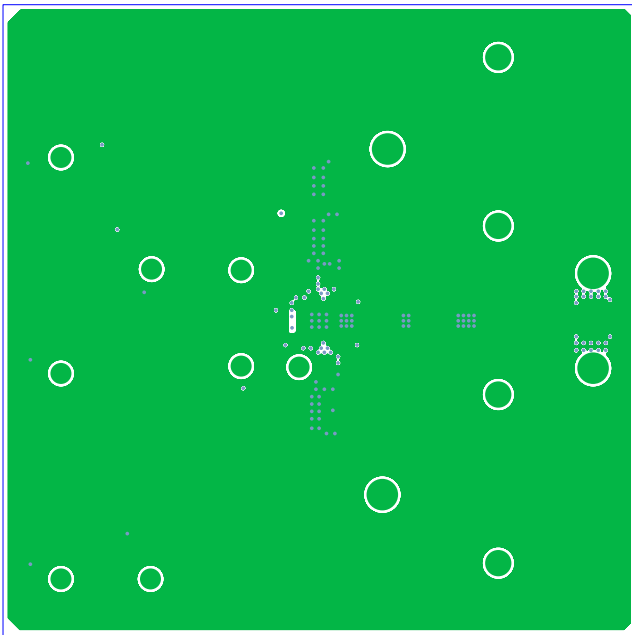

FIGURE 3. 2ND LAYER ETCH

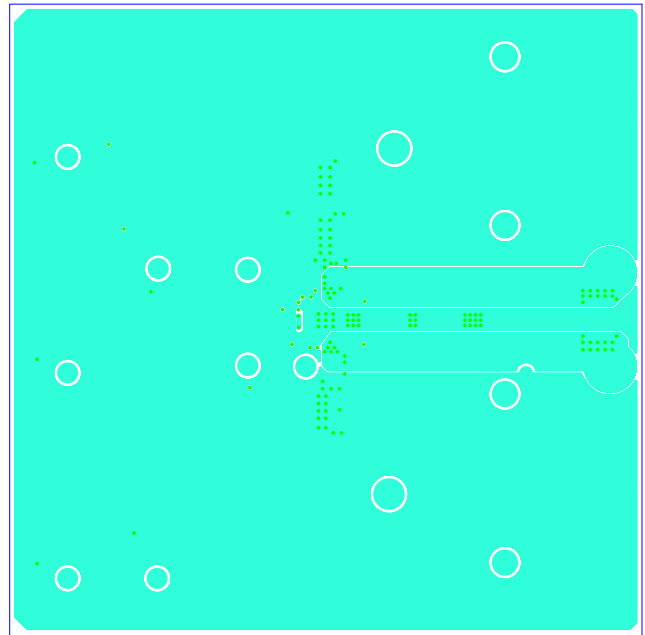

FIGURE 4. 3RD LAYER ETCH

# ISL78236DUALEVAL1Z Board Layout (Continued)

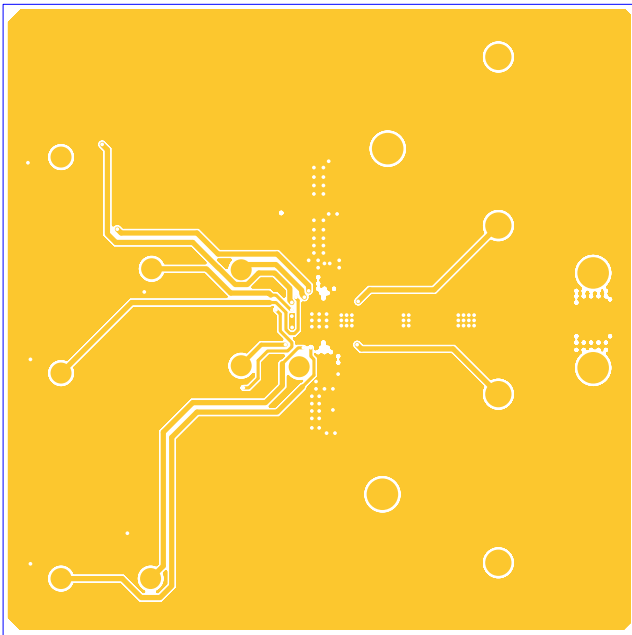

FIGURE 5. BOTTOM LAYER ETCH

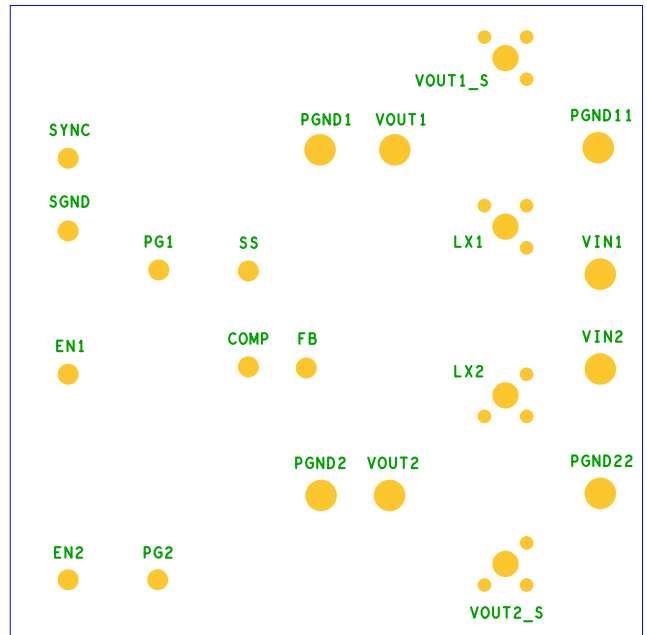

FIGURE 6. BOTTOM COMPONENTS (MIRROR)