

ISL78263EVAL1Z

User's Manual: Evaluation Board

Automotive

All information contained in these materials, including products and product specifications, represents information on the product at the time of publication and is subject to change by Renesas Electronics Corp. without notice. Please review the latest information published by Renesas Electronics Corp. through various means, including the Renesas Electronics Corp. website (<http://www.renesas.com>).

ISL78263EVAL1Z

Evaluation Board

The ISL78263EVAL1Z board evaluates the dual-converter, synchronous buck-and-boost operation of the ISL78263. The board evaluates Converter 1, a synchronous buck operation that provides a system rail voltage, and Channel 2, a boost converter that is activated to support automotive cold crank applications. In addition, the ISL78263EVAL1Z helps you work with ISL78263 features such as overcurrent protection, overvoltage and undervoltage protection, and power-good indicators for each channel.

Key Features

- V_{IN} operating range: 2.1V to 42V
- Selectable Continuous Conduction Mode (CCM) or Energy Conservation Mode (ECM) allowed
- Low quiescent current in ECM Mode: 6 μ A typical, buck channel
- Switching frequency: 200kHz to 2.2MHz
- Boost frequency at 1x or 0.2x the buck frequency
- Dropout mode (buck) for high duty-cycle operation
- 25ns on-times for low duty-cycle operation
- External synchronization
- Programmable spread spectrum clocking
- 2A Sourcing / 3A sinking MOSFET drivers
- Boot UVLO and programmable boot refresh time
- Extensive protection mechanisms for OV/UV/OC/OT
- Monitoring test points for key signals

Specifications

This board is configured and optimized for the following operating conditions:

- V_{IN_TYP} = 12 to 14V
- V_{IN_MIN} = 2.1V (typical)
- V_{IN_MAX} = 42V (typical)
- V_{OUT1} = 5V (up to 10A)
- V_{BOOST} = 10V when activated
- f_{SW} = 2.2MHz

See ["Operating Range" on page 4](#) for detailed descriptions

Ordering Information

Part Number	Description
ISL78263EVAL1Z	ISL78263 Evaluation Board

Related Literature

For a full list of related documents, visit our website:

- [ISL78263](#) device page

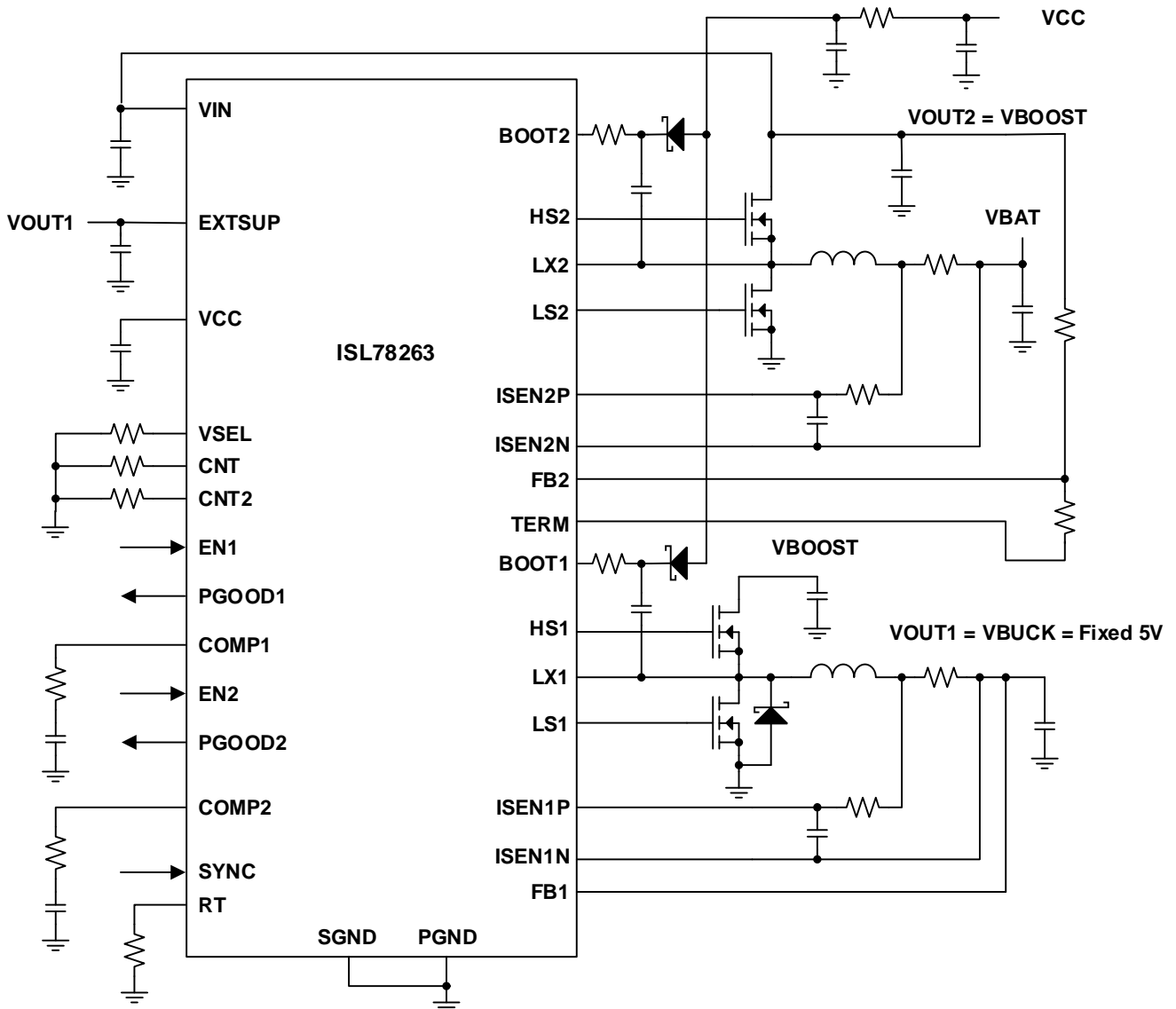

Figure 1. Typical Cold Crank Applications Schematic (Channel 1 Fixed at 5V)

1. Functional Description

The ISL78263EVAL1Z evaluation board pictures are shown in [Figures 1](#) and [2](#). The board supports a quick evaluation of the ISL78263 features and the power solution that provides a system rail voltage capable of withstanding automotive cold crank applications. The ISL78263EVAL1Z evaluates the features of the ISL78263 supporting automotive applications powered from a car battery.

1.1 Recommended Equipment

- VBAT (V_{IN} supply): 50V power supply with a 30A source current capability
- Output Loads: One load capable of > 10A
- Digital Multimeters (DMM) and/or oscilloscope to monitor various voltages

1.2 Operating Range

- Enable operation:
 - S1 controls EN for Converter1, and S2 controls EN2 for Converter 2.
 - EN1 has a 100k Ω resistor to V_{IN} to allow the auto-start of channel 1 when V_{IN} is applied.
 - EN2 has a 10k Ω pull-up resistor to VCC, requiring V_{CC} to be present for channel 2 to be enabled.
 - The converters can start when the input voltage, V_{IN} , rises above 5.65V (typical)
- V_{IN_MIN} = 2.1V (typical) with boost converter enabled.
- V_{IN_TYP} = 12V
- V_{IN_MAX} = 42V (typical)
- I_{OUT_MAX} = 10A
- f_{SW} = 2.2 MHz as selected with R16 = 6.81k Ω
- The board is set in ECM mode by default with J10 (FCCM) open:
 - Allows for R46 (100k Ω) to pull SYNC pin low.
- The board is set to connect a 5V output from channel 1 to EXTSUP (U1-20), with a jumper shorting the J15 pins 2 and 3, providing an efficient 5V source for control and gate drive power.
- Switches S3 and S4 allow setting operating configurations (as detailed in the datasheet):
 - S3 should have position 8 as **ON** to connect VSEL (U1-3) to R31 (54.9k Ω) to ground, allowing for the selection of channel 1 with a 5V fixed voltage and cold crank support.
 - S3 should have position 4 as **ON** to connect VSEL (U1-1) to R27 (75k Ω) to ground, allowing for the selection of a Boot refresh time of 300ns and $f_{SW}(\text{boost}) = f_{SW}(\text{buck})$.
 - S4 should have position 3 as **ON** to connect VSEL (U1-3) to R34 (14.7k Ω) to ground, allowing for the selection of a minimum dead time and Spread Spectrum **OFF**.

1.3 External Connections and Setup Before Start-Up

- Connect the V_{IN} power supply between VBAT (J1) and GND (J2). Before typical start-up, set the V_{IN} power supply voltage to 12V. The power supply output should be off before start-up
- For initial startup, set S1 and S2 to the **OFF** position
- Connect the electronic load between VBUCK (J6) and GND (J5). Set the electronic load to 0A for the initial start-up. The load should be off before start-up.
- Appropriately place the DMMs or oscilloscope where the signals are measured.
- Switch S1 to the **ON** position to enable VBUCK.
- Switch S2 to the **ON** position to enable the boost converter.

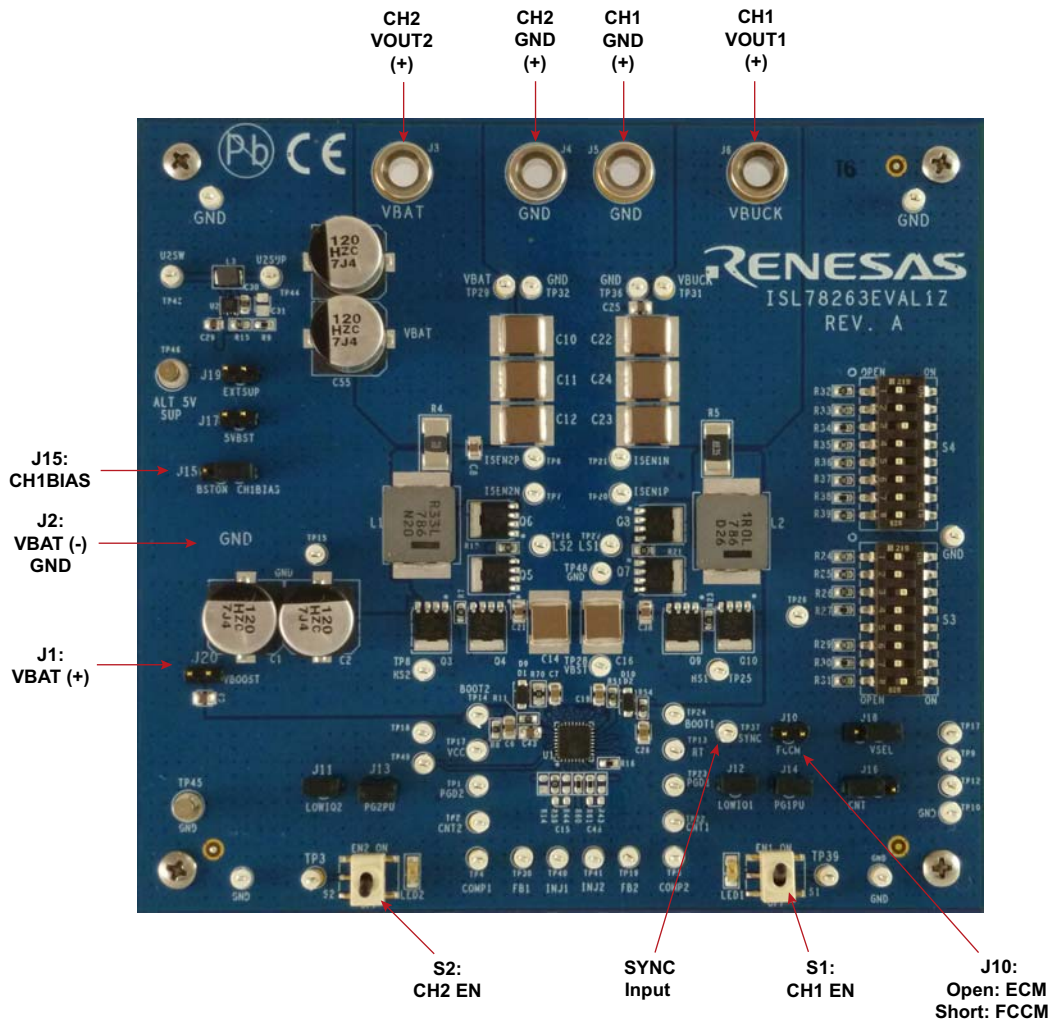

Figure 2. Board Connection Guideline

2. PCB Layout Guidelines

2.1 ISL78263EVAL1Z Evaluation Board

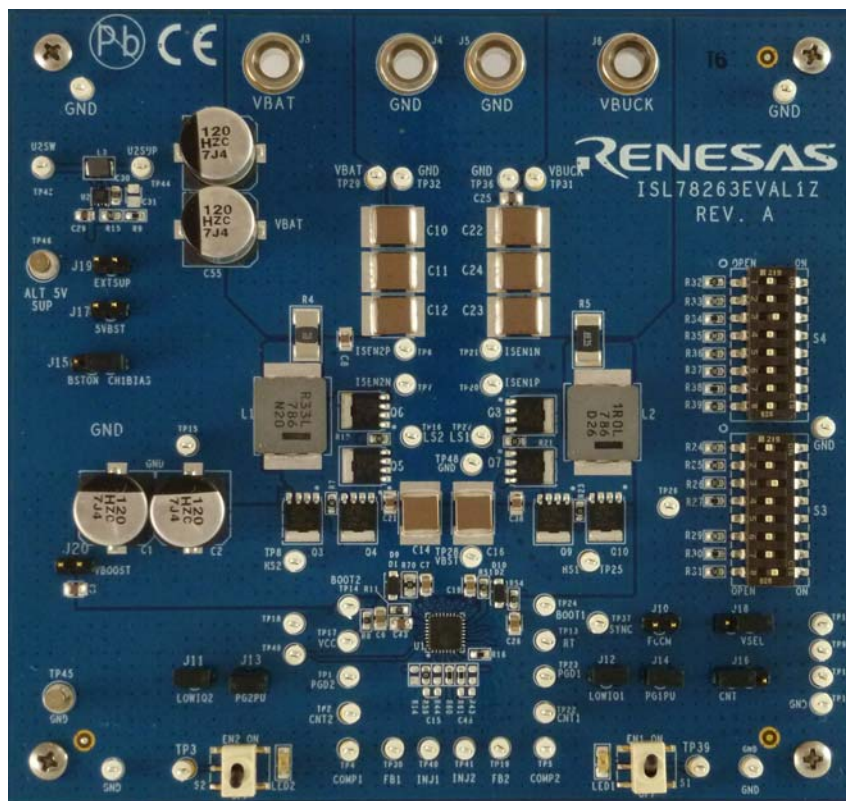

Figure 3. ISL78263EVAL1Z Evaluation Board (Top)

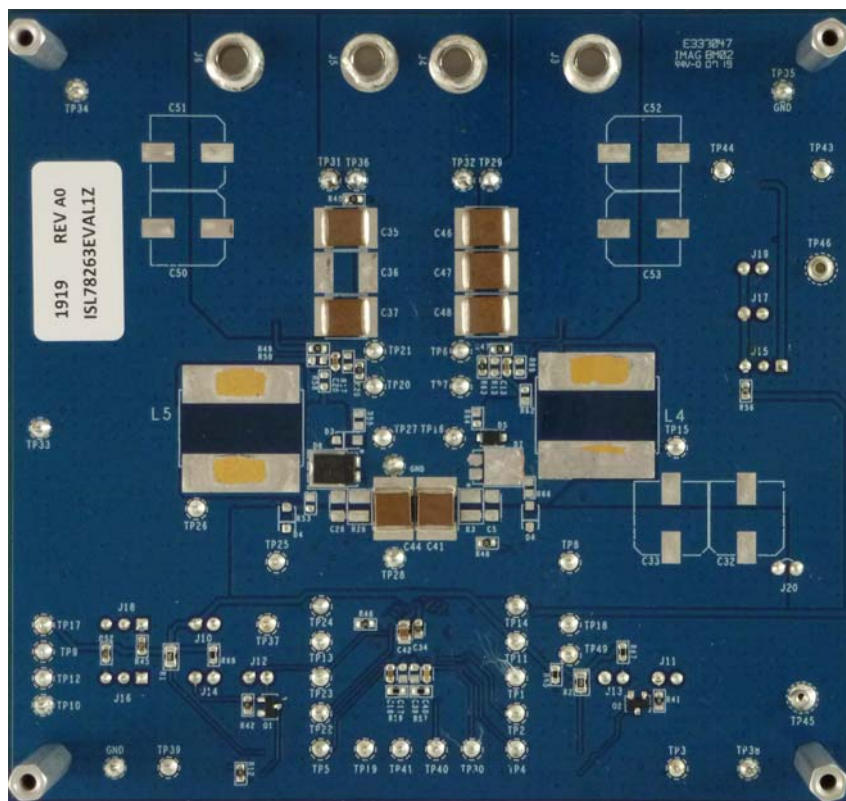

Figure 4. ISL78263EVAL1Z Evaluation Board (Bottom)

Table 1. Connector/Monitor Pin Descriptions

Connector/ Test Point	Signal Name	Description
J1	VBAT	V_{IN} supply connection for positive input.
J2	GND	V_{IN} supply GND connection.
J3	VOUT2	VOUT2 connection to load.
J4	GND	VOUT2 GND connection to load.
J5	GND	VOUT1 GND connection to load.
J6	VOUT1	VOUT1 connection to load.
J10	FCCM	Jumper open to allow ECM operation; install to force FCCM.
J11	LOWIQ2	Jumper typically installed for PGOOD2; open to measure low I_Q .
J12	LOWIQ1	Jumper typically installed for PGOOD1; open to measure low I_Q .
J13	PG2PU	Jumper typically installed for PGOOD2; open to measure low I_Q .
J14	PG1PU	Jumper typically installed for PGOOD1; open to measure low I_Q .
J15	BST_ON/CH1_BIAS	Jumper typically connects VOUT1 to EXTSUP1.
J16	CNT	Jumper installed to connect S4 and the CNT configuration resistor.
J17	5VBST	Jumper typically open and can be used to connect U2-2 to EXTSUP1.
J18	VSEL	Jumper installed to connect S3 and the VSEL configuration resistor.
J19	ALT_5V_SUP	Jumper typically open and can be installed to use alternate bias supply.
TP1	PGD2	Test point to monitor PGOOD2 on pin U1-32.
TP2	CNT2	Test point to monitor CNT2 on pin U1-14.
TP3	EN2	Test point to monitor EN2 on pin U1-4.
TP4	COMP1	Test point to monitor COMP1 on pin U1-6.
TP5	COMP2	Test point to monitor COMP2 on pin U1-7.
TP6	ISEN2P	Test point to monitor ISEN2P on pin U1-28.
TP7	ISEN2N	Test point to monitor ISEN2N on pin U1-27.
TP8	HS2	Test point to monitor HS2 on pin U1-24.
TP10	GND	
TP11	VCC	Test point to monitor V_{CC} .
TP13	RT	Test point to monitor RT on pin U1-8.
TP14	BOOT2	Test point to monitor BOOT2 on pin U1-25.
TP15	LX2	Test point to monitor BOOT2 on pin U1-23.
TP16	LS2	Test point to monitor LS2 on pin U1-22.
TP17	VCC	Test point to monitor V_{CC} on pin U1-19.
TP18	EXTSUP	Test point to monitor EXTSUP on pin U1-20.
TP19	FB2	Test point to monitor FB2 on pin U1-5.
TP20	ISEN1P	Test point to monitor ISEN1P on pin U1-10.
TP21	ISEN1N	Test point to monitor ISEN1N on pin U1-9.
TP22	CNT	Test point to monitor CNT on pin U1-14.
TP23	PGD1	Test point to monitor PGOOD1 on pin U1-12.
TP24	BOOT1	Test point to monitor BOOT1 on pin U1-15.
TP25	HS1	Test point to monitor HS1 on pin U1-16.
TP26	LX1	Test point to monitor LX1 on pin U1-19.

Table 1. Connector/Monitor Pin Descriptions (Continued)

TP27	LS1	Test point to monitor LS1 on pin U1-18
TP28	VBAT	Test point to monitor VBAT supply voltage.
TP29	VOUT2	Test point to monitor VOUT2 voltage.
TP30	FB1	Test point to monitor FB1 on pin U1-2.
TP32	VOUT1	Test point to monitor VOUT1 voltage.
TP10, TP33, TP34, TP35, TP36, TP38, TP42, TP45, TP48	GND	Test point to connect to GND.
TP37	SYNC	Test point to monitor SYNC pin U1-13.
TP39	EN1	Test point to monitor EN1 pin U1-29.
TP40	INJ1	Test point to inject a signal for a channel 1 control loop evaluation.
TP41	INJ2	Test point to inject a signal for a channel 2 control loop evaluation.
TP43	U2_SW	Test point to monitor voltage on pin U2-8.
TP44	U2_SUP	Test point to monitor voltage on pin U2-7.
TP46	ALT_5V_SUP	Test point to monitor voltage on J19-2.

2.2 ISL78263EVAL1Z Circuit Schematic

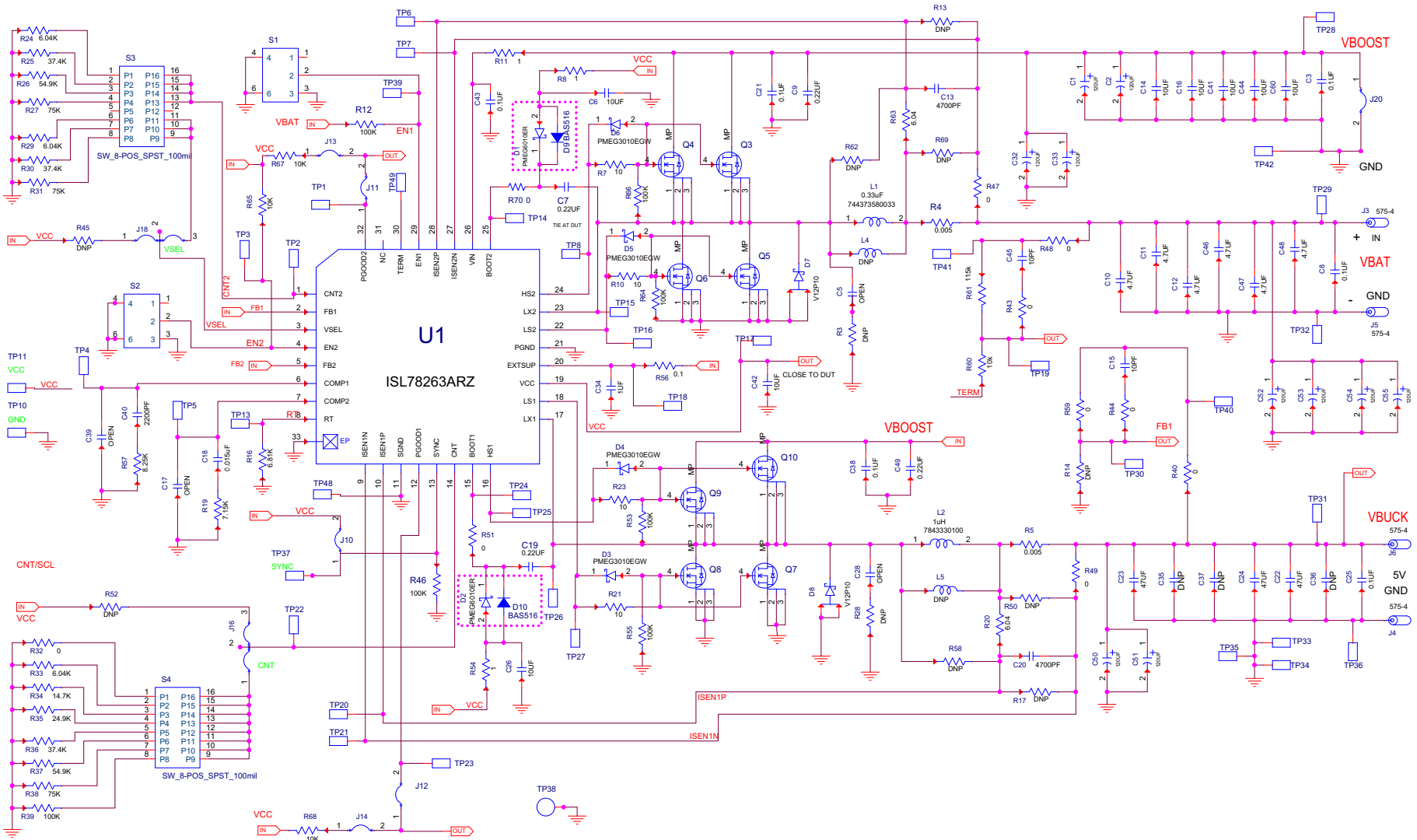

Figure 5. Schematic (1 of 2)

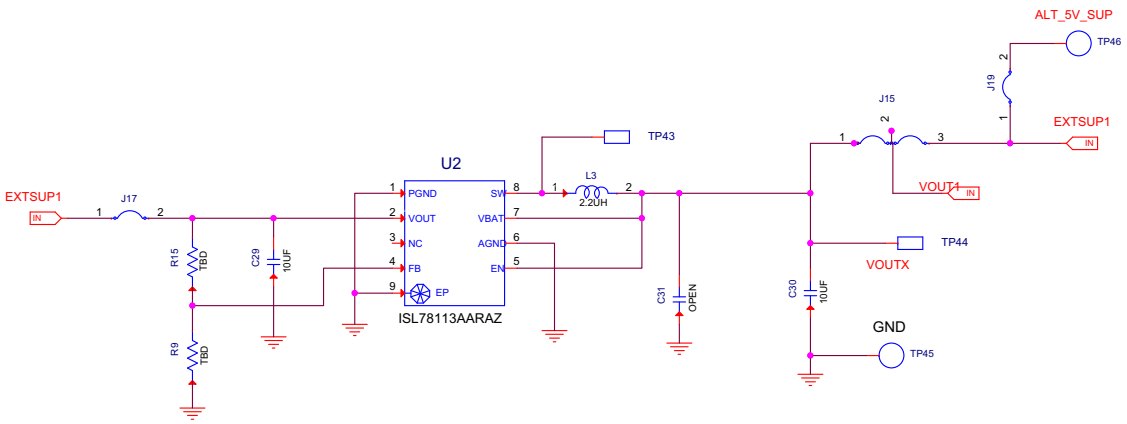
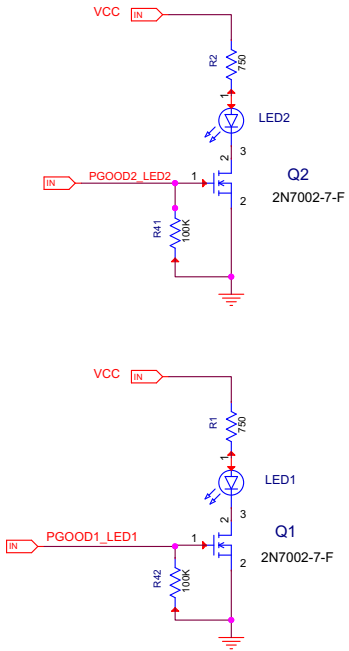

Figure 6. Schematic (2 of 2)

2.3 Bill of Materials

Reference Designator	Description	Mfr	Manufacturer Part Number
B1	PWB-PCB, ISL78263EVAL1Z, REVA, ROHS	Imagineering	ISL78263EVAL1ZREVAPCB
C1, C2, C54, C55	CAP-AEC-Q200, SMD, 10.3mm, 120 μ F, 50V, 20%, 28m Ω , ROHS	Panasonic	EEH-ZC1H121P
C32, C33, C52, C53	CAP-AEC-Q200, SMD, 10.3mm, DNP-PLACE HOLDER, ROHS	Panasonic	EEH-ZC1H121P
C3, C8, C21, C25, C38, C43	CAP-AEC-Q200, SMD, 0805, 0.1 μ F, 100V, 10%, X7R, ROHS	TDK	CGA4J2X7R2A104K125AA
C10, C11, C12, C14, C16, C41, C44, C46, C47, C48	CAP-AEC-Q200, SMD, 2220, 10 μ F, 50V, 10%, X7R, ROHS	TDK	C5750X5R1H106K230KA
C6, C26, C42	CAP-AEC-Q200, SMD, 0805, 10 μ F, 10V, 10%, X7R, ROHS	Murata	GCJ21BR71A106KE01L
C22, C23, C24, C35, C37	CAP-AEC-Q200, SMD, 2220, 47 μ F, 16V, 20%, X7R, ROHS	TDK	CGA9N3X7R1C476M230KB
C36	CAP-AEC-Q200, SMD, 2220, DNP-Placeholder, ROHS	TDK	CGA9N3X7R1C476M230KB
C13, C20	CAP-AEC-Q200, SMD, 0603, 4700pF, 100V, 10%, X7R, ROHS	Murata	GCM188R72A472KA37D
C29, C30	CAP, SMD, 0603, 10 μ F, 16V, 10%, X5R, ROHS	Murata	GRM188R61C106KAALD
C18	CAP, SMD, 0603, 0.1 μ F, 25V, 10%, X7R, ROHS	TDK	CGA3E2X7R1E104K080AA
C40	CAP, SMD, 0603, 2200pF, 100V, 10%, X7R, ROHS	Venkel	C0603X7R101-222KNE
C7, C19	CAP, SMD, 0805, 0.22 μ F, 100V, 10%, X7R, ROHS	Kemet	C0805C224K1RACAUTO
C34	CAP, SMD, 0603, 1.0 μ F, 16V, 10%, X7R, ROHS	TDK	C1608X7R1C105K
L1	COIL-PWR Inductor, SMD, 10.9x10, 0, 0.33 μ H, 39A, 20%, 1.21m Ω , ROHS	Panasonic	ETQ-P5MR33YLC
L2	COIL-PWR Inductor, SMD, 10.9x10, 0, 1 μ H, 27A, 20%, 2.53m Ω , ROHS	Panasonic	ETQ-P5M1R0YLC
L3	COIL-Inductor, SMD, 1210, 2.2 μ H, 30%, 1.85A, 76.8m Ω , WW, ROHS	Murata	LQH32PN2R2NNCL
TP45, TP46	CONN-Turret, Terminal Post, TH, ROHS	Keystone	1514-2
TP1-TP8, TP10, TP11, TP13-TP44, TP48, TP49	CONN-Mini Test Point, Vertical, White, ROHS	Keystone	5002
J3, J4, J5, J6	CONN-Jack, MINI Banana, 0.175 Plug	Keystone	575-4
J10, J11, J12, J13, J14, J17, J19, J20	CONN-Header, 1x2, Breakaway 1x36, 2.54mm, ROHS	Berg/FCI	68000-236HLF
J15, J16, J18	CONN-Header, 1x3, Breakaway 1x36, 2.54mm, ROHS	Berg/FCI	68000-236HLF
J11, J12, J13, J14, J15-Pins 2-3, J16-Pins 1-2, J18-Pins 2-3.	CONN-Jumper, Shorting, 2PIN, Black, Gold, ROHS	Sullins	SPC02SYAN
D1, D2, D5	Diode-Schottky, SMD, 2P, SOD123W, 60V, 1A, ROHS	Nexperia	PMEG6010ER,115
D7, D8	Diode-Schottky, SMD, TO-277A(SMPC), 100V, 12A, ROHS	Vishay	V12P10-M3/86A
LED1, LED2	LED, SMD, 1206, Green, 30mA, 60mW, ROHS	Dialight	5973311407NF

Reference Designator	Description	Mfr	Manufacturer Part Number
U1	IC-Dual Buck Controller, 32P, WFQFN, 5x5, ROHS	Renesas Electronics America	ISL78263ARZ
U2	IC-Synchronous Boost Converter, 8P, DFN, ROHS	Renesas Electronics America	ISL78113AARAZ
Q1, Q2	Transistor, N-Channel, 3LD, SOT-23, 60V, 115mA, ROHS	Diodes, Inc.	2N7002-7-F
Q3-Q10	Transistor-MOS, N-Channel, SMD, 4P, LFPK, 40V, 33A, 18.mΩ, ROHS	NXP	BUK9Y21-40E,115
R20, R63	RES-AEC-Q200, SMD, 0603, 6.04Ω, 1/10W, 1%, TF, ROHS	Vishay/Dale	CRCW06036R04FKEA
R56	RES-AEC-Q200, SMD, 0603, 0.1Ω, 1/4W, 1%, ROHS	Panasonic	ERJ-3BSFR10V
R8, R11, R54	RES, SMD, 0603, 1Ω, 1/10W, 1%, TF, ROHS	Panasonic	ERJ-3RQF1R0V
R7, R21, R23, R32, R40, R47, R48, R49, R59, R70	RES, SMD, 0603, 0Ω, 1/10W, TF, ROHS	Venkel	CR0603-10W-000T
R43, R44	RES, SMD, 0603, DNP-Placeholder, ROHS	Venkel	CR0603-10W-000T
R60, R65, R67, R68	RES, SMD, 0603, 10k, 1/10W, 1%, TF, ROHS	Venkel	CR0603-10W-1002FT
R19	RES, SMD, 0603, 3.32k, 1/10W, 1%, TF, ROHS	Panasonic	ERJ-3EKF3321V
R12, R39, R41, R42, R46	RES, SMD, 0603, 100k, 1/10W, 1%, TF, ROHS	Venkel	CR0603-10W-1003FT
R53, R55, R64, R66	RES, SMD, 0603, DNP-Placeholder, ROHS	Venkel	CR0603-10W-1003FT
R30, R34	RES, SMD, 0603, 14.7k, 1/10W, 1%, TF, ROHS	Venkel	CR0603-10W-1472FT
R9	RES, SMD, 0603, 150k, 1/10W, 1%, TF, ROHS	Yageo	RC0603FR-07150KL
R61	RES, SMD, 0603, 117k, 1/10W, 1%, TF, ROHS	Panasonic	ERJ-3EKF1173V
R25, R35	RES, SMD, 0603, 24.9k, 1/10W, 1%, TF, ROHS	Panasonic	ERJ-3EKF2492V
R36	RES, SMD, 0603, 37.4k, 1/10W, 1%, TF, ROHS	Yageo	RC0603FR-0737K4L
R26, R31, R37	RES, SMD, 0603, 54.9k, 1/10W, 1%, TF, ROHS	Panasonic	ERJ-3EKF5492V
R24, R29, R33	RES, SMD, 0603, 6.04k, 1/10W, 1%, TF, ROHS	Venkel	CR0603-10W-6041FT
R16	RES, SMD, 0603, 6.81k, 1/10W, 1%, TF, ROHS	Yageo	RC0603FR-076K81L
R27, R38	RES, SMD, 0603, 75k, 1/10W, 1%, TF, ROHS	Venkel	CR0603-10W-7502FT
R15	RES, SMD, 0603, 787k, 1/10W, 1%, TF, ROHS	Yageo	RC0603FR-07787KL
R57	RES, SMD, 0603, 8.25kΩ, 1/10W, 1%, TF, ROHS	Panasonic	ERJ-3EKF8251V
R1, R2	RES, SMD, 0805, 750Ω, 1/8W, 1%, TF, ROHS	Panasonic	ERJ-6ENF7500V
R4	RES-AEC-Q200, SMD, 2512, 0.003Ω, 2W, 1%, MF, ROHS	Vishay/Dale	WSL25123L000FEA
R5	RES-AEC-Q200, SMD, 2512, 0.005Ω, 2W, 1%, MF, ROHS	Vishay/Dale	WSL25125L000FEA18
R10, R51	RES, SMD, 0603, 4.7Ω, 1/10W, 5%, TF, ROHS	Panasonic	ERJ-PA3J4R7V
S3, S4	Switch-Slide DIP, SMD, 8POS, SPST, 100mA, 12V, ROHS	CTS Elect. Components	219-8MSTR
S1, S2	Switch-Toggle, SMD, 6PIN, SPDT, 2POS, ROHS	ITT Industries/C&K Division	GT11MSCBE

2.4 Board Layout

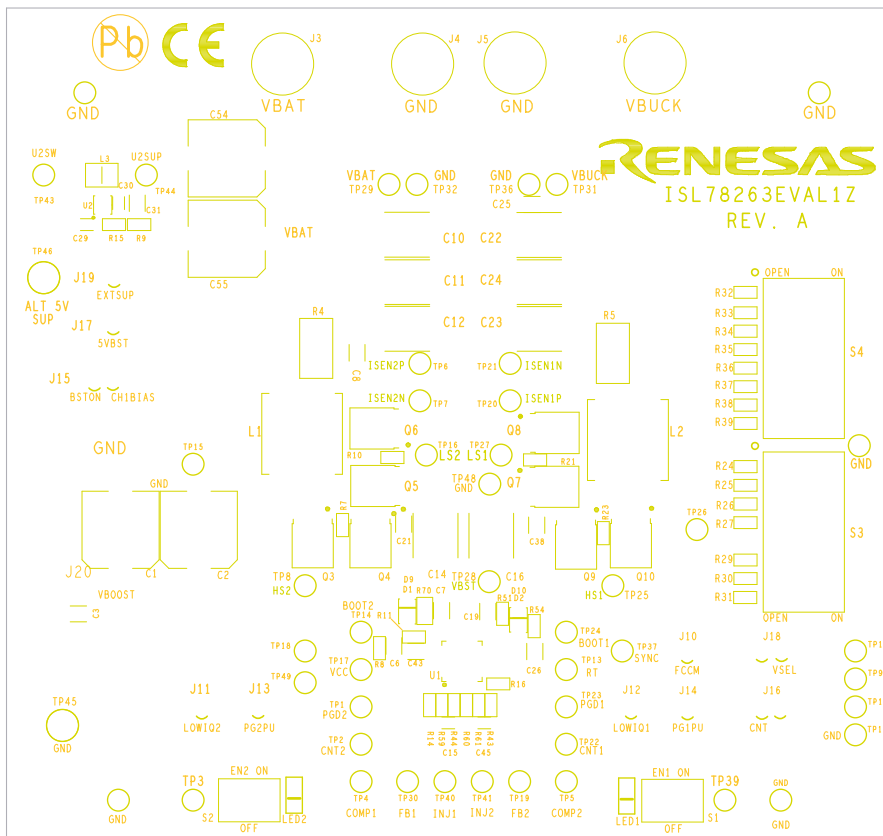

Figure 7. Silkscreen Top

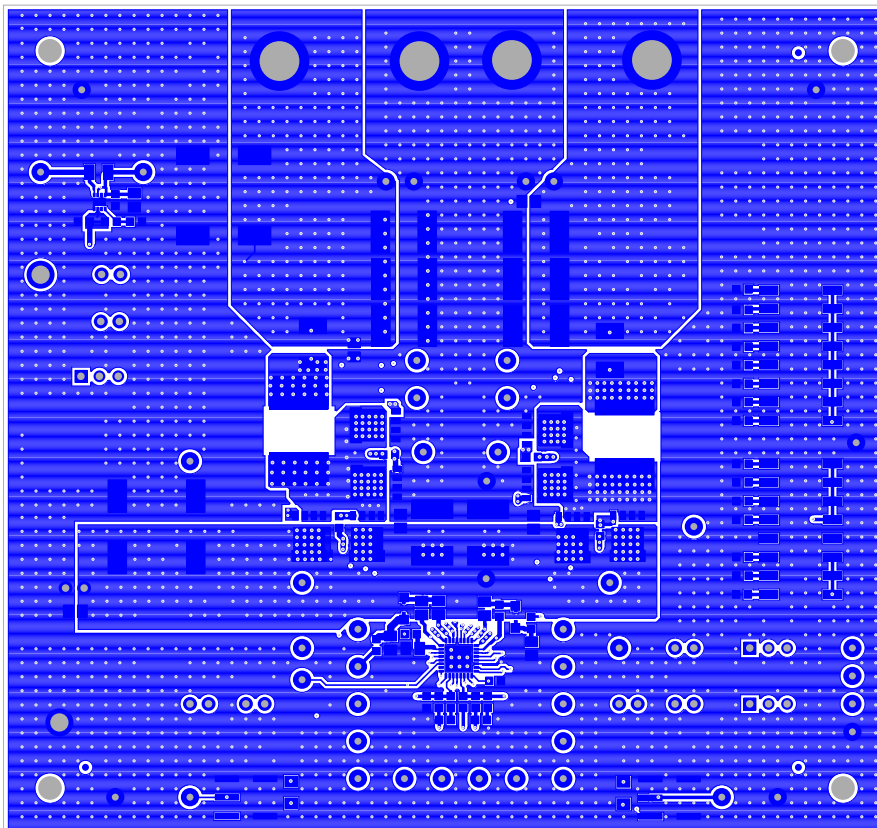

Figure 8. Layer 1

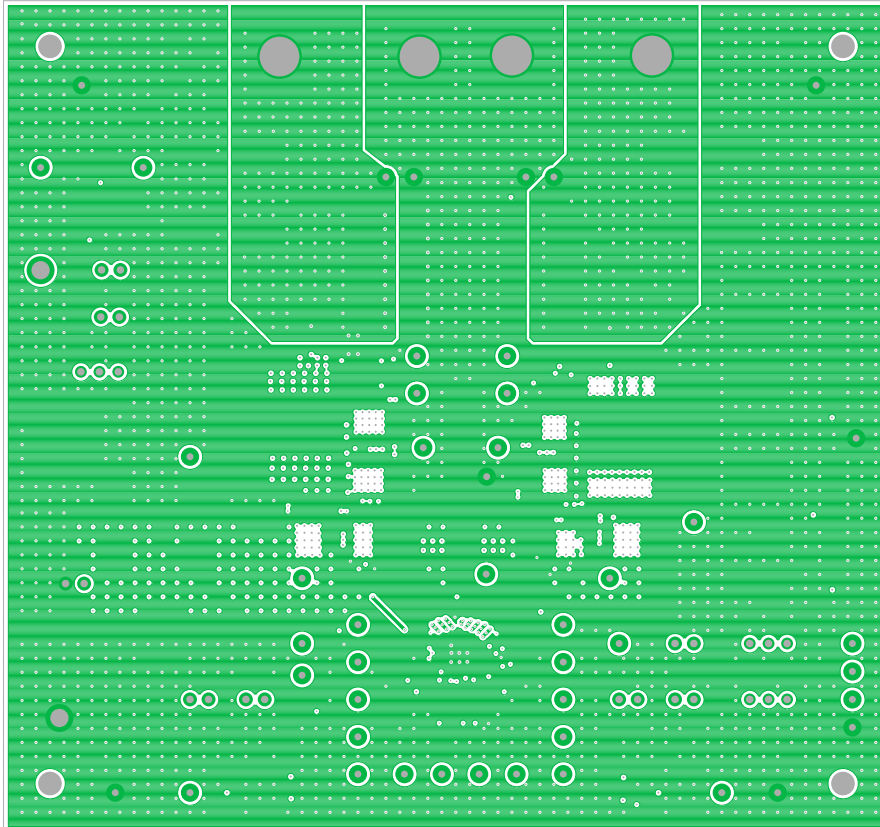

Figure 9. Layer 2

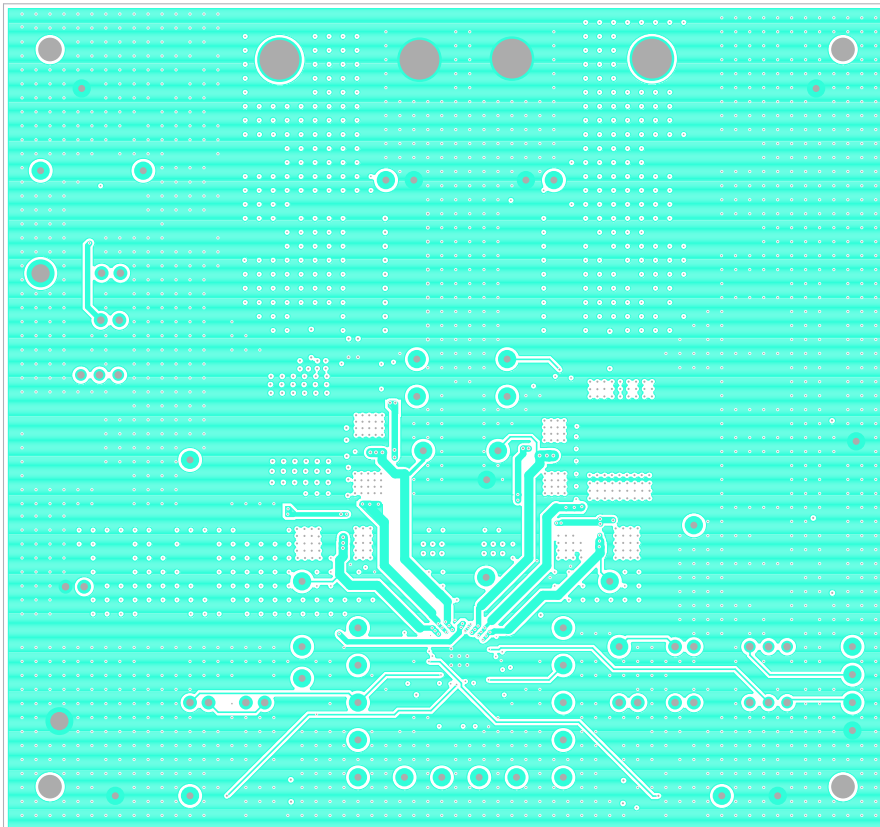

Figure 10. Layer 3

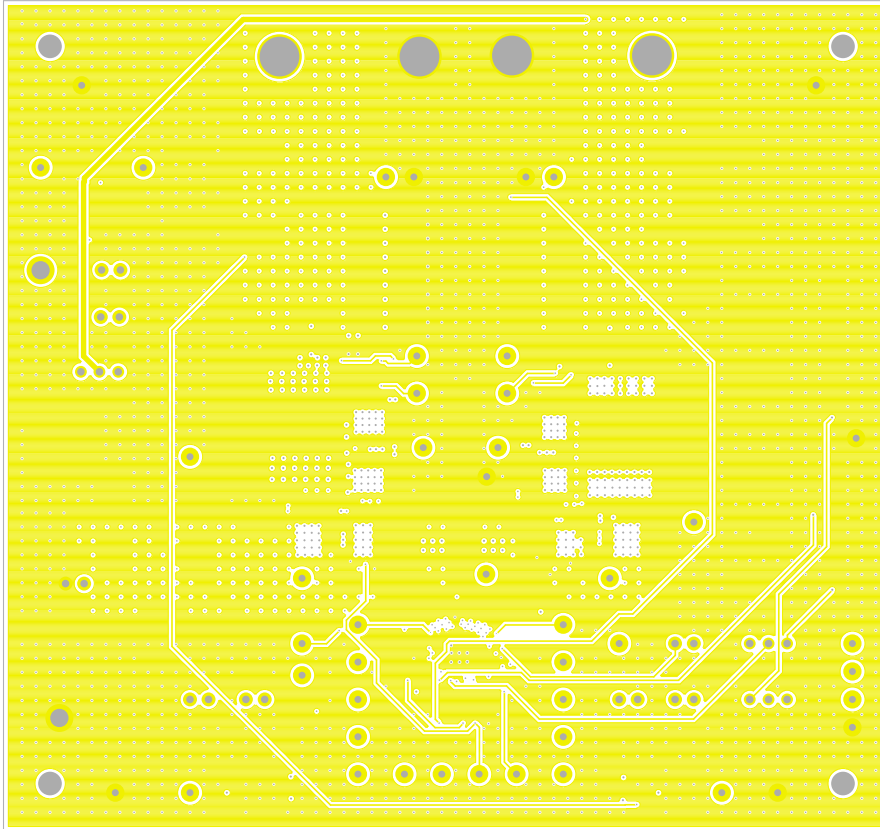

Figure 11. Layer 4

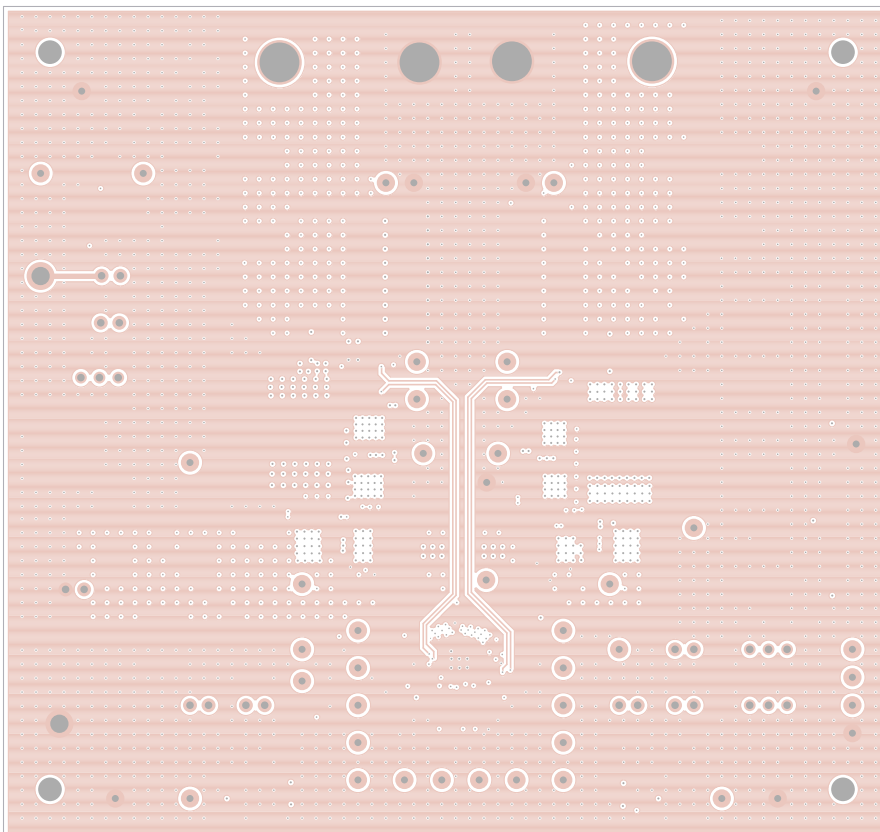

Figure 12. Layer 5

3. Typical Performance Curves

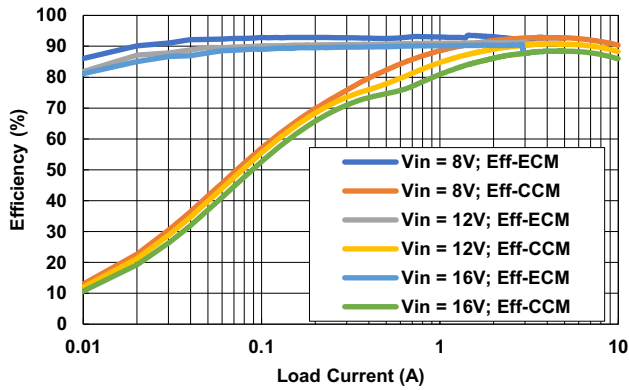

Figure 15. Buck Efficiency (VOUT1 = 5V, f_{SW} = 2.2MHz)

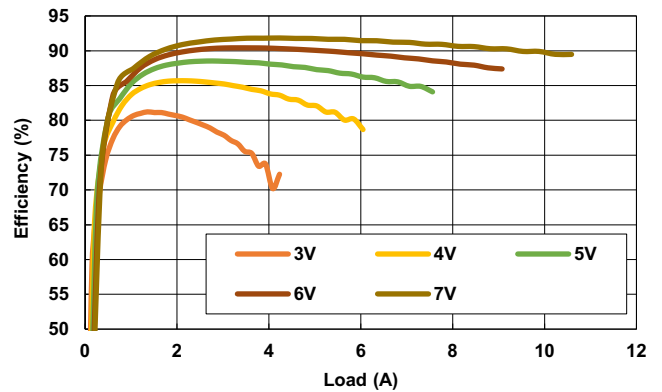

Figure 16. Boost Efficiency (VOUT2 = 10V, f_{SW} = 2.2MHz)

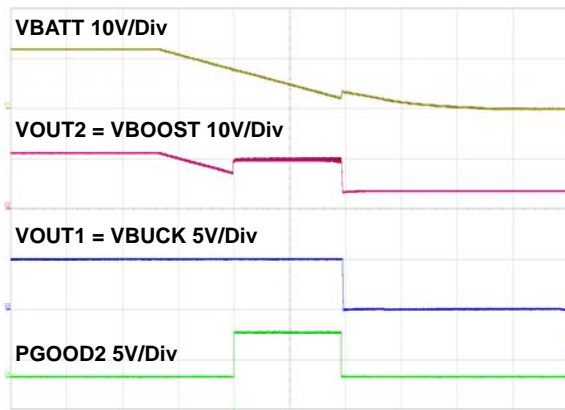

Figure 17. V_{IN} Fall with BOOST Turn ON/OFF

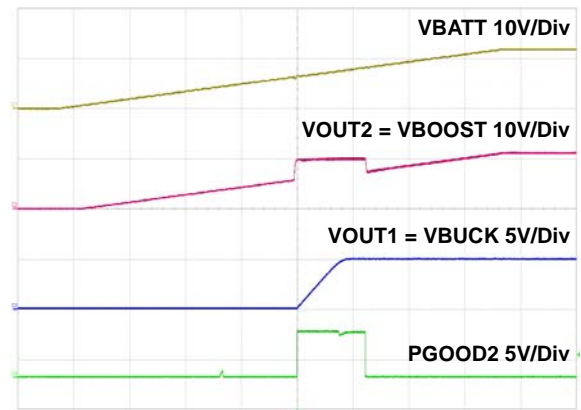

Figure 18. V_{IN} Rise with BOOST Turn ON/OFF

4. Revision History

Rev.	Date	Description
1.01	Jul.31.20	Corrected third feature bullet. Updated schematic
1.00	Jul.24.20	Initial release

ISL78263EVAL1Z