

## ISL8012EVAL1Z: 2A Synchronous Buck Regulator with Integrated MOSFETs

### 2A Low Quiescent Current 1MHz High Efficiency Synchronous Buck Regulator

ISL8012 is an integrated power controller rate for the 2A, 1MHz step-down regulator, which is ideal for any low power, low-voltage application. It is optimized for generating low output voltages down to 0.8V. The supply voltage range is from 2.7V to 5.5V, allowing for the use of a single Li+ cell, three NiMH cells or a regulated 5V input. It has a guaranteed minimum output current of 2A. 1MHz pulse-width modulation (PWM) switching frequency allows using small external components. It has flexible operation mode selection of forced PWM mode and PFM mode with as low as 35µA quiescent current for highest light load efficiency to maximize battery life.

The ISL8012 includes a pair of low ON-resistance P-Channel and N-Channel internal MOSFETs to maximize efficiency and minimize external component count. 100% duty-cycle operation allows less than 400mV dropout voltage at 2A.

The ISL8012 offers a 1ms Power-On-Reset (PG) timer at power-up. The timer output can be reset by RSI. When shutdown, ISL8012 discharges the output capacitor. Other features include internal digital soft-start, enable for power sequence, overcurrent protection and thermal shutdown.

The ISL8012 is offered in a 3mmx3mm 10 Ld DFN package with 1mm maximum height. The complete converter occupies less than 1cm<sup>2</sup> area.

### Ordering Information

PART NUMBER (Notes 1, 2, 3)	PART MARKING	TEMP. RANGE (°C)	PACKAGE (Pb-Free)	PKG. DWG. #
ISL8012IRZ	012Z	-40 to +85	10 Ld 3x3 DFN	L10.3x3C

#### NOTES:

1. Add "-T" or suffix for tape and reel. Please refer to [TB347](#) for details on reel specifications.
2. These Intersil Pb-free plastic packaged products employ special Pb-free material sets, molding compounds/die attach materials, and 100% matte tin plate plus anneal (e3 termination finish, which is RoHS compliant and compatible with both SnPb and Pb-free soldering operations). Intersil Pb-free products are MSL classified at Pb-free peak reflow temperatures that meet or exceed the Pb-free requirements of IPC/JEDEC J STD-020.
3. For Moisture Sensitivity Level (MSL), please see device information page for [ISL8012](#). For more information on MSL please see techbrief [TB363](#).

### Features

- High Efficiency Synchronous Buck Regulator with up to 95% Efficiency
- 1ms Reset Timer
- Soft Discharge Output Cap During Enable
- 2.7V to 5.5V Supply Voltage
- 3% Output Accuracy Over-Temperature/Load/Line
- 2A Guaranteed Output Current
- 25µA Quiescent Supply Current in PFM Mode
- Selectable Forced PWM Mode and PFM Mode
- Less Than 1µA Logic Controlled Shutdown Current
- 100% Maximum Duty Cycle for Lowest Dropout
- Internal Current Mode Compensation
- Internal Digital Soft-Start
- Peak Current Limiting, Short Circuit Protection
- Over-Temperature Protection
- Enable
- Small 10 Ld 3mmx3mm DFN
- Pb-Free (RoHS Compliant)

### Applications

- DC/DC POL Modules
- µC/µP, FPGA and DSP Power
- Plug-in DC/DC Modules for Routers and Switchers
- PGtable Instruments
- Test and Measurement Systems

### Pinout

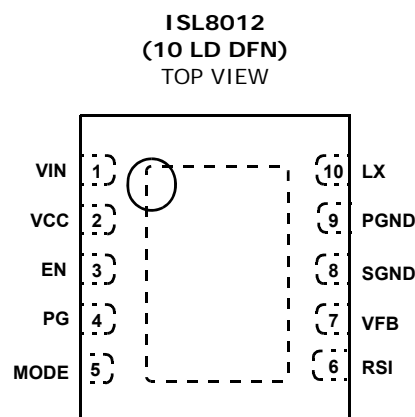

## What's Inside

The Evaluation Board Kit contains the following materials:

- The ISL8012EVAL1Z REVC Board
- The ISL8012 Data Sheet
- This EVAL KIT Application Note

## Recommended Equipment

The following materials are recommended to perform testing:

- 0V to 10V power supply with at least 3A source current capability, battery and notebook AC adapter
- Two electronic loads capable of sinking current up to 5A
- Digital multimeters (DMMs)
- 100MHz quad-trace oscilloscope
- Signal generator

## Quick Setup Guide

1. Ensure that the circuit is correctly connected to the supply and loads prior to applying any power.
2. Connect the bias supply to VIN, the plus terminal to P4 (VIN) and the negative return to P5 (GND).
3. Verify that SW1 is in the ON position.
4. Turn on the power supply.
5. Verify the output voltage is 1.8V for V<sub>OUT</sub>

## Evaluating the Other Output Voltage

The ISL8012EVAL1Z kit output is preset to 1.8V; however, output voltages can be adjusted from 0.8V to 3.3V using Equations 1 and 2:

$$V_{OUT} = 0.8 \left( 1 + \frac{R_1}{R_2} \right) \quad (\text{EQ. 1})$$

Let's set  $R_2 = 100\text{k}\Omega$

$$R_1 = R_2 \left( \frac{V_{OUT}}{0.8} - 1 \right) \quad (\text{EQ. 2})$$

If the desired output is 0.8V, short  $R_1$  and open  $R_2$ .

## Mode Control

The ISL8012 has a MODE pin that controls the operation mode. When the MODE pin is driven to low or shorted to ground, the regulator operates in a forced PWM mode. The forced PWM mode remains the fixed PWM frequency at light load instead of entering the skip mode.

TABLE 1. SWITCH SETTINGS

SW2	SKIP	FUNCTION
	PWM	Fixed PWM Frequency at Light Load
	PFM	Force Continuous Mode
SW1	ENABLE	ON/OFF CONTROL
	OFF	Disable V <sub>OUT</sub>
	ON	Enable V <sub>OUT</sub>

# ISL8012EVAL1Z Schematic

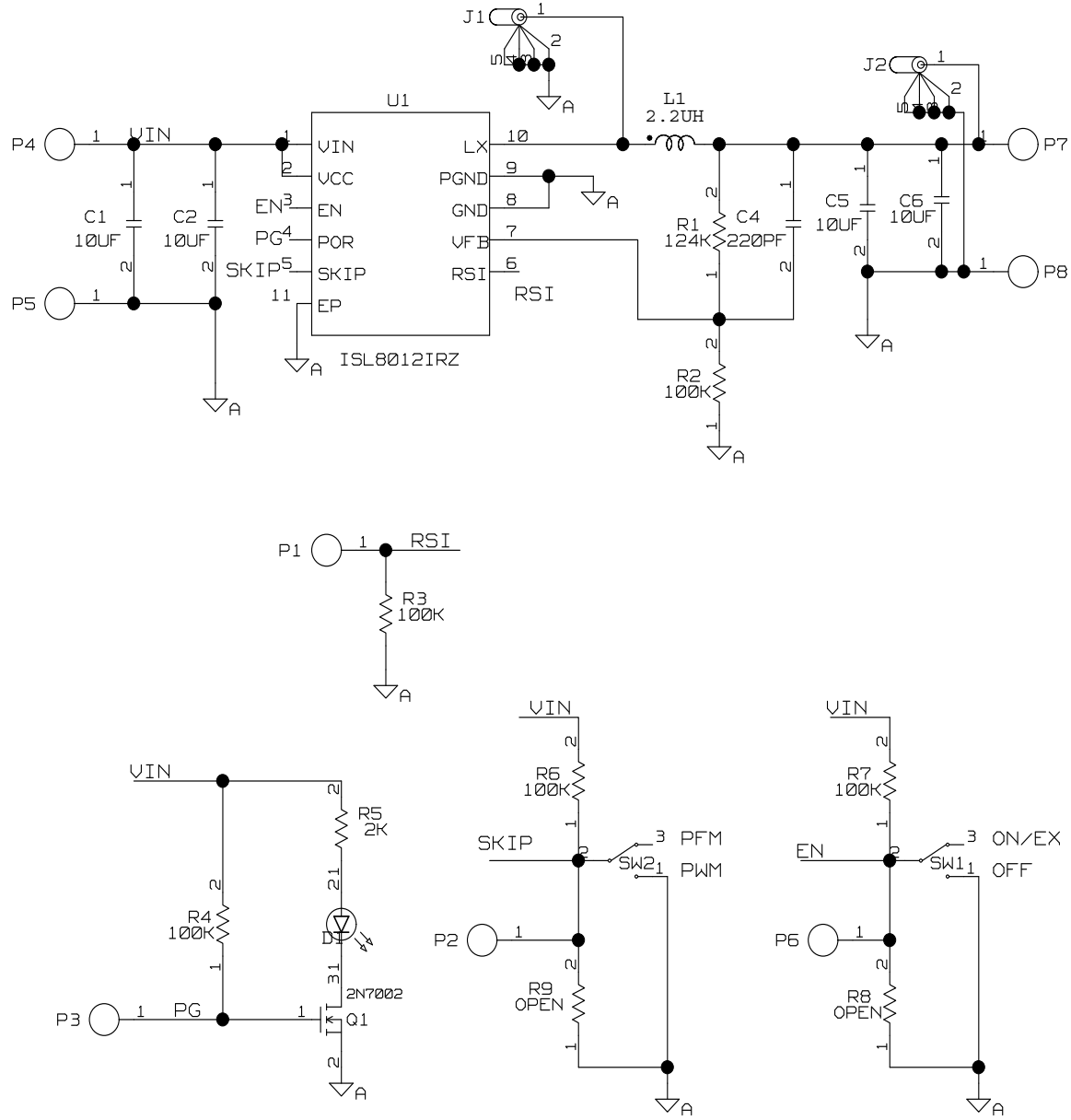

TABLE 2. BILL OF MATERIALS

PART NUMBER	QTY	UNITS	REFERENCE DESIGNATOR	DESCRIPTION	MANUFACTURER	MANUFACTURER PART
ISL8012EVAL1ZREVCPCB	1	ea		PWB-PCB, ISL8012EVAL1Z, REVC, ROHS	IMAGINEERING INC	ISL8012EVAL1ZREVCPCB
GRM31CR71A106KA01L-T	4	ea	C1, C2, C5, C6	CAP, SMD, 1206, 10µF, 10V, 10%, X7R, ROHS, MONOLITHIC	MURATA	GRM31CR71A106KA01L
H1045-00221-50V5-T	1	ea	C4	CAP, SMD, 0603, 220pF, 50V, 5%, COG, ROHS	VENKEL	C0603COG500-221JNE
DR73-2R2-R	1	ea	L1	COIL-PWR INDUCTOR, SMD, 7.6X6, 2.2uH, 20%, 4.15A, ROHS	COOPER ELECTRONIC TECH.	DR73-2R2-R
131-5031-00	2	ea	J1, J2	CONN-SCOPE PROBE TEST PT, COMPACT, PCB MNT, ROHS	TEKTRONIX	131-5031-00
1514-2	4	ea	P4, P5, P7, P8	CONN-TURRET, TERMINAL POST, TH, ROHS	KEYSTONE	1514-2
5002	4	ea	P1-P3, P6	CONN-MINI TEST POINT, VERTICAL, WHITE, ROHS	KEYSTONE	5002
LTST-C170CKT	1	ea	D1	LED-GaAs RED, SMD, 2mmX1.25mm, 100mW, 40mA, 10mcd, ROHS	LITEON/VISHAY	LTST-C170CKT
ISL8012IRZ	1	ea	U1	IC-2A SYNCH. BUCK REGULATOR, 10P, DFN, 2X3, ROHS	INTERSIL	ISL8012IRZ
2N7002-7-F-T	1	ea	Q1	TRANSISTOR, N-CHANNEL, 3LD, SOT-23, 60V, 115mA, ROHS	DIODES, INC.	2N7002-7-F
H2511-01003-1/10W1-T	5	ea	R2-R4, R6, R7	RES, SMD, 0603, 100k, 1/10W, 1%, TF, ROHS		
H2511-01243-1/10W1-T	1	ea	R1	RES, SMD, 0603, 124k, 1/10W, 1%, TF, ROHS	YAGEO	9C06031A1243FKHFT
H2511-02001-1/10W1-T	1	ea	R5	RES,SMD,0603, 2k, 1/10W, 1%, TF, ROHS	KOA	RK73H1JTTD2001F
H2511-DNP	0	ea	R8, R9	RES, SMD, 0603, DNP-PLACE HOLDER, ROHS		
GT11MSCBE-T	2	ea	SW1, SW2	SWITCH-TOGGLE, SMD, 6PIN, SPDT, 2POS, ON-ON, ROHS	ITT INDUSTRIES/ C&K DIVISION	GT11MSCBE
4-40X1/2-SCREW	4	ea	Four corners.	SCREW, 4-40X1/2in, PAN, NYLON, PHILLIPS, ROHS		
4-40X3/4-STANDOFF	4	ea	Four corners.	STANDOFF, 4-40X3/4in, F/F, HEX, NYLON	KEYSTONE	1902D
5X8-STATIC-BAG	1	ea	Place assy in bag.	BAG, STATIC, 5X8, ZIP LOC	INTERSIL	212403-013
LABEL-SERIAL NUMBER	1	ea		LABEL, FOR SERIAL NUMBER AND BOM REV #		

## ISL8012EVAL1Z Board Layout

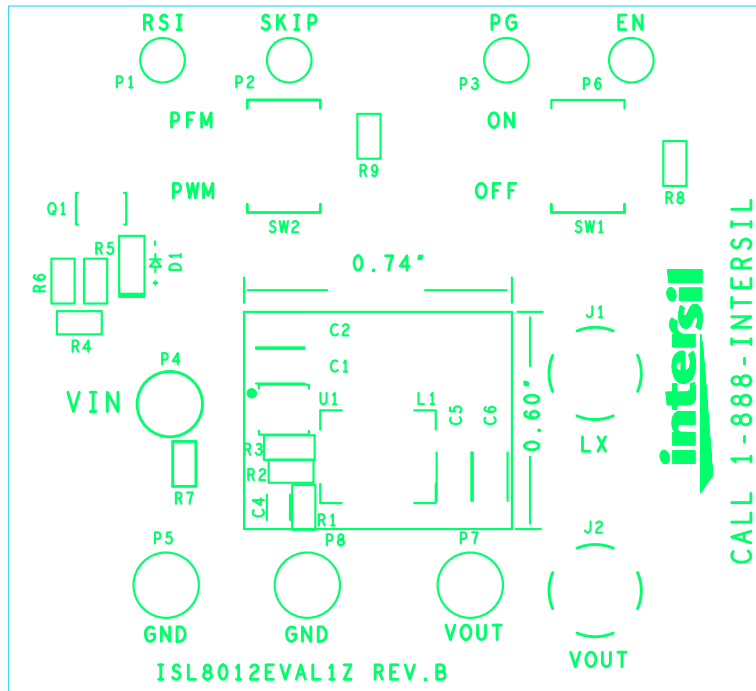

FIGURE 1. TOP COMPONENTS

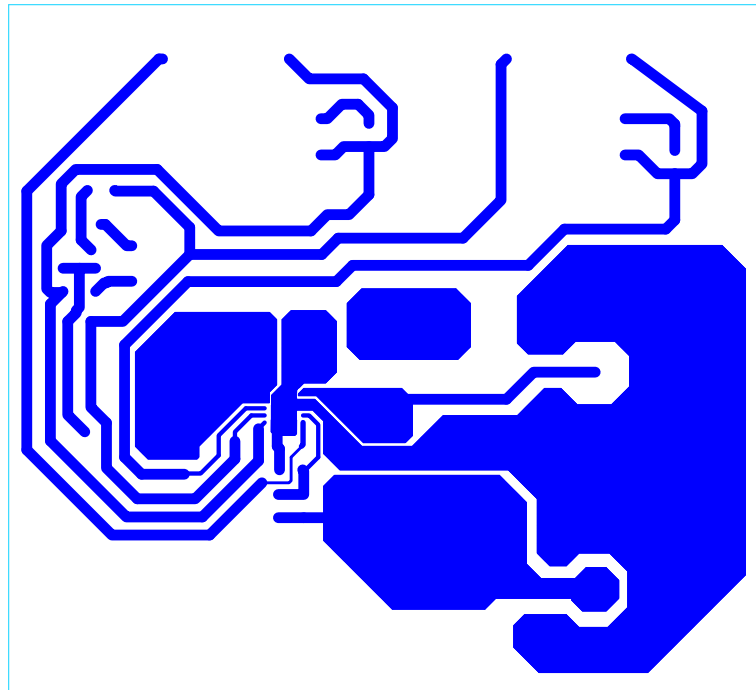

FIGURE 2. TOP LAYER ETCH

## ISL8012EVAL1Z Board Layout (Continued)

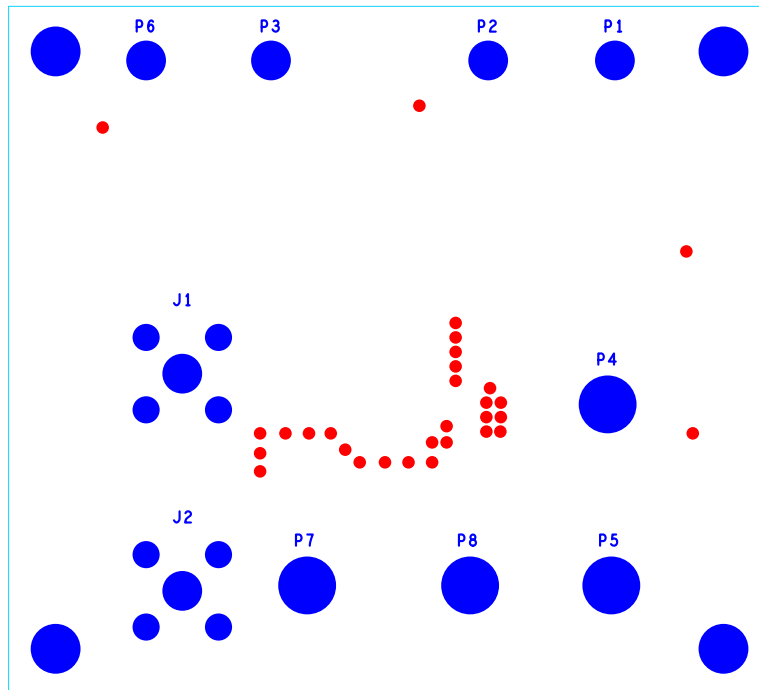

FIGURE 3. BOTTOM LAYER COMPONENTS (MIRRORED)

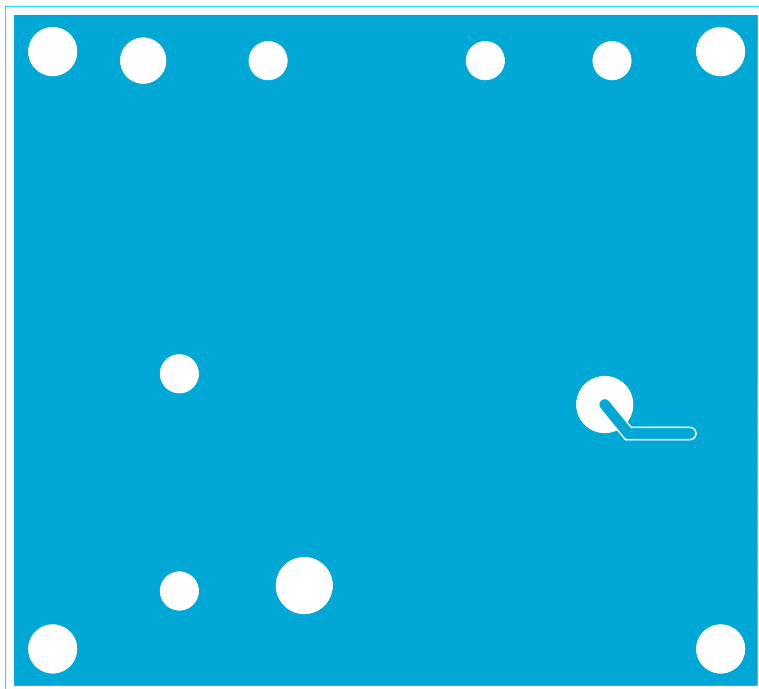

FIGURE 4. BOTTOM LAYER ETCH (MIRRORED)