

ISL8025xEVAL3Z Evaluation Board User Guide

Description

The ISL8025 and ISL8025A evaluation board kits are intended for use by customers with requirements for Point-of-Load applications sourcing from 2.7V to 5.5V. The ISL8025 and ISL8025A evaluation boards are used to demonstrate the performance of the ISL8025 and ISL8025A, low quiescent high efficiency synchronous buck regulator.

The ISL8025 and ISL8025A are offered in a 3mmx3mm 16 Ld TQFN package with 1mm maximum height. The complete area that the converter occupies can be as small as 0.22in².

Specifications

| PART NUMBER | I _{OUT} (MAX) (A) | F _{SW} RANGE (MHz) | V _{IN} RANGE (V) | V _{OUT} RANGE (V) | PART SIZE (2mm) |
|-------------|----------------------------|-----------------------------|---------------------------|----------------------------|-----------------|
| ISL8025 | 5 | Programmable 0.5 to 4MHz | 2.7V to 5.5V | 0.6V to 5.5V | 3x3 |
| ISL8025A | | Programmable 1 to 4MHz | | | |

NOTES:

- The Evaluation Kits default configuration are V_{OUT} = 1.8V for ISL8025EVAL3Z (f_{SW} = 1MHz) and ISL8025AEVAL3Z (f_{SW} = 2MHz).
- V_{REF} is 0.6V.

Key Features

- High efficiency synchronous buck regulator with up to 95% efficiency
- 0.8% reference accuracy over temperature load line
- Start-up with pre biased output
- Internal soft-start - 1ms or adjustable
- Soft-stop output discharge during disabled
- Adjustable frequency from 500kHz to 4MHz - default at 1MHz (2MHz for ISL8025A)
- External synchronization up to 4MHz
- Negative OC protection

References

[ISL8025 Datasheet](#)

Ordering Information

| PART NUMBER | DESCRIPTION |
|----------------|-------------------------------|
| ISL8025EVAL3Z | Evaluation Board For ISL8025 |
| ISL8025AEVAL3Z | Evaluation Board For ISL8025A |



FIGURE 1. ISL8025EVAL3Z



FIGURE 2. ISL8025AEVAL3Z

Recommended Equipment

The following materials are recommended to perform testing:

- 0V to 10V power supply with at least 10A source current capability or 5V battery
- Electronic loads capable of sinking current up to 7A
- Digital Multimeters (DMMs)
- 100MHz quad-trace oscilloscope
- Signal generator

Quick Setup Guide

1. Ensure that the circuit is correctly connected to the supply and loads prior to applying any power.
2. Connect the bias supply to V_{IN} , the plus terminal to V_{IN} , P4 and the negative return to PGND, P5.
3. Connect the output load to V_{OUT} , the plus terminal to VO, P3 and the negative return to PGND, P7.
4. Verify that the position is PWM for SW2.
5. Verify that the position is ON for SW1.
6. Turn on the power supply.
7. Verify the output voltage is 1.8V for V_{OUT} .

Evaluating the Other Output Voltage

The ISL8025 and ISL8025A evaluation board kits output are preset to 1.8V for V_{OUT} , however, output voltages can be adjusted from 0.6V to 5V. The output voltage programming resistor, R_1 , will depend on the desired output voltage of the regulator. The value for the feedback resistor is typically between 0 Ω and 200k Ω , as shown in [Equation 1](#).

$$R_2 = R_1 \left(\frac{V_{FB}}{V_O - V_{FB}} \right) \quad (\text{EQ. 1})$$

If the output voltage desired is 0.6V, then R_2 is left unpopulated and R_1 is shorted. For faster response performance, add 10pF to 47pF in parallel to R_1 . Check bode plot to insure optimum performance.

Frequency Control

The ISL8025 and ISL8025A have an FS pin that controls the frequency of operation. Programmable frequency allows for optimization between efficiency and external component size. Default switching frequency is 1MHz for ISL8025EVAL3Z and 2MHz for ISL8025AEVAL3Z when FS is tied to V_{IN} ($R_{11} = 0$ and R_{12} is open). By changing the value of R_{12} , the switching frequency can be changed from 500kHz to 4MHz according to [Equation 2](#):

$$R_T [\text{k}\Omega] = \frac{220 \cdot 10^3}{f_{\text{OSC}} [\text{kHz}] - 14} \quad (\text{EQ. 2})$$

When using R_{12} to adjust the operational frequency, this also sets external compensation mode. Please refer to the [ISL8025](#), [ISL8025A](#) datasheet for more details.

Soft-start Control

Short CSS to SGND for internal soft-start (approximately 1ms). Populate CSS to adjust the soft-start time. This capacitor, along with an internal 1.6 μ A current source, sets the soft-start interval of the converter, t_{SS} .

$$CSS [\mu\text{F}] = 3.33 \cdot t_{SS} [\text{s}] \quad (\text{EQ. 3})$$

CSS must be less than 33nF to insure proper soft-start reset after fault condition.

Switches Control

The ISL8025, ISL8025A evaluation boards contain SW1 and SW2 for various controls of the ISL8025, ISL8025A circuitries. [Table 1](#) details this function.

TABLE 1. SWITCH SETTINGS

| SW1 | ENABLE | FUNCTION |
|-----|--------|-----------------------------------|
| 1 | OFF | DISABLE VO |
| 3 | ON | ENABLE VO |
| | | |
| SW2 | MODE | FUNCTION |
| 1 | PWM | Fixed PWM frequency at light load |
| 3 | PFM | Force continuous mode |

PCB Layout Recommendation

The PCB layout is a very important converter design step to make sure the designed converter works well. For ISL8025, ISL8025A, the power loop is composed of the output inductor L's, the output capacitor (COUT), the PHASE pins, and the PGND pin. It is necessary to make the power loop as small as possible and the connecting traces among them should be direct, short and wide. The switching node of the converter, the PHASE pins, and the traces connected to the node are very noisy, so keep the voltage feedback trace away from these noisy traces. The input capacitor should be placed as close as possible to the VIN pin. The ground of input and output capacitors should be connected as close as possible. The heat of the IC is mainly dissipated through the thermal pad. Maximizing the copper area connected to the thermal pad is preferable. In addition, a solid ground plane is helpful for better EMI performance. It is recommended to add at least 5 vias ground connection within the pad for the best thermal relief.

ISL8025xEVAL3Z Schematic

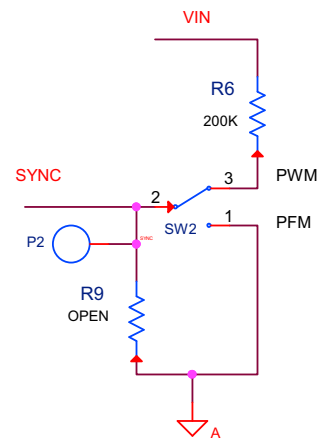
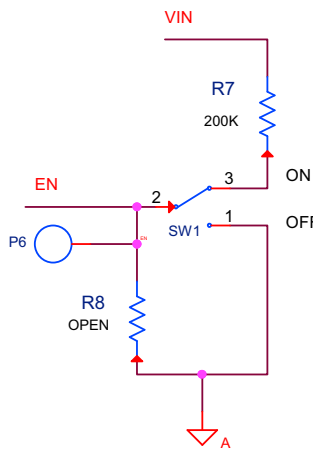
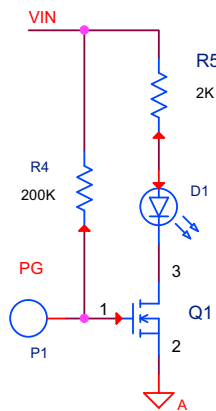
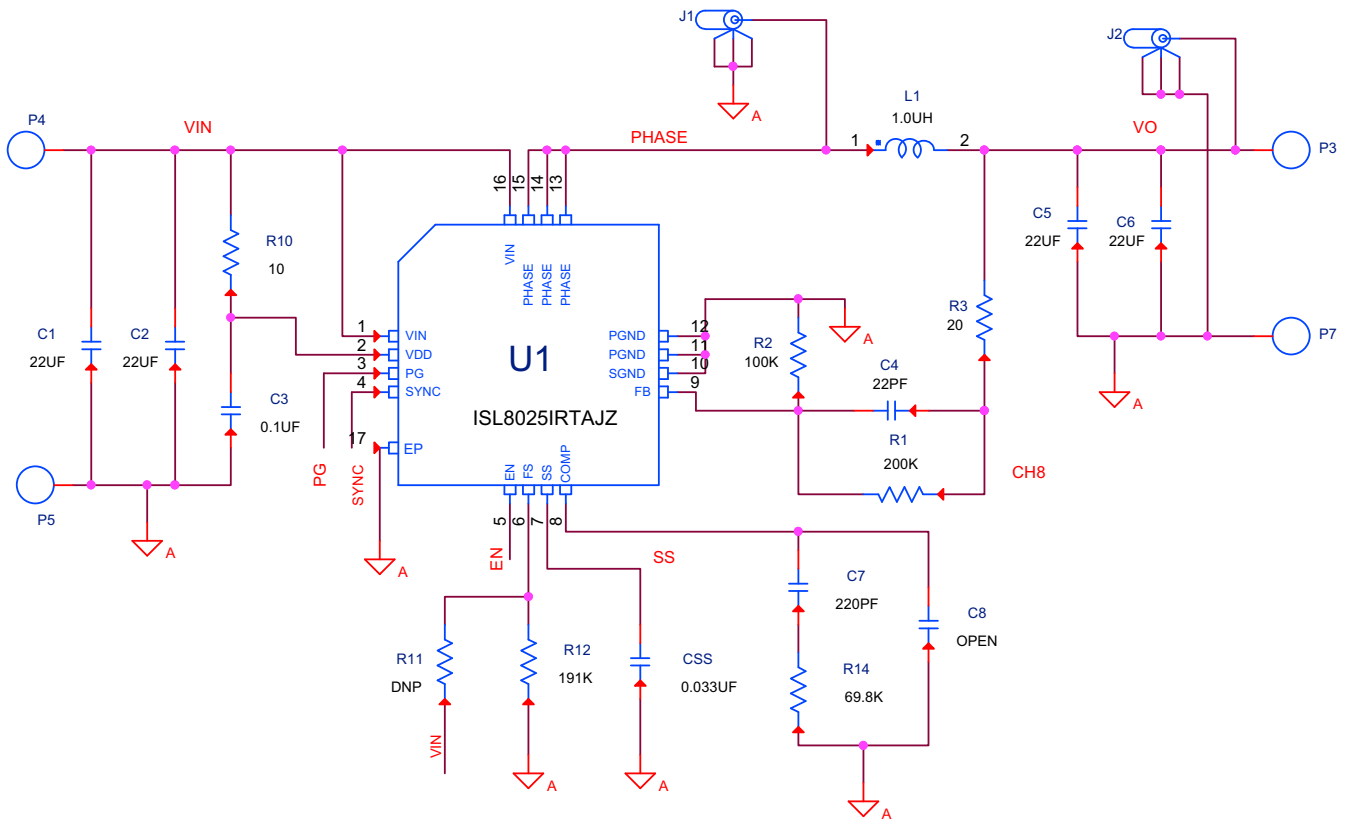

Application Note 1806

Bill Of Materials

| PART NUMBER | QTY | UNITS | REFERENCE DESIGNATOR | DESCRIPTION | MANUFACTURER | MANUFACTURER PART |
|----------------------|-----|-------|----------------------|---|-----------------------------|---------------------|
| ISL8025REVAPCB | 1 | ea. | | PWB-PCB, ISL8025, REVA, ROHS | IMAGINEERING INC | ISL8025REVAPCB |
| H1045-00220-50V5-T | 1 | ea. | C4 | CAP, SMD, 0603, 22pF, 50V, 5%, COG, ROHS | VENKEL | C0603C0G500-220JNE |
| H1045-00221-50V10-T | 1 | ea. | C7 | CAP, SMD, 0603, 220pF, 50V, 10%, X7R, ROHS | MURATA | GRM188R71H221KA01D |
| H1045-00333-16V10-T | 1 | ea. | CSS | CAP, SMD, 0603, 33000pF, 16V, 10%, X7R, ROHS | VENKEL | C0603X7R160-333KNE |
| H1045-00104-16V10-T | 1 | ea. | C3 | CAP, SMD, 0603, 0.1μF, 16V, 10%, X7R, ROHS | VENKEL | C0603X7R160-104KNE |
| H1045-DNP | 0 | ea. | C8 | CAP, SMD, 0603, DNP-PLACE HOLDER, ROHS | | |
| H1065-00226-6R3V10-T | 4 | ea. | C1, C2, C5, C6 | CAP, SMD, 1206, 22μF, 6.3V, 10%, X5R, ROHS | MURATA | GRM31CR60J226KE19L |
| MPLCG0530L1R0 | 1 | ea. | L1 (ISL8025) | 1μH, 14.6mΩ, 5.6A, ROHS, SHIELDED | TOKIN | MPLCG0530L1R0 |
| S13100004 | 1 | ea. | L1 (ISL8025) | 1μH, 13.7mΩ, 16A, ROHS, SHIELDED | WURTH ELEKTRONIK | S13100004 |
| FDV0530S-R78M | 1 | ea. | L1 (ISL8025A) | 0.78μH, 20%, 14mΩ, 7.1A, ROHS, SHIELDED | TOKO | FDV0530S-R78M |
| 131-4353-00 | 2 | ea. | J1, J2 | CONN-SCOPE PROBE TEST PT, COMPACT, PCB MNT, ROHS | TEKTRONIX | 131-4353-00 |
| 1514-2 | 4 | ea. | P4, P5, P7, P8 | CONN-TURRET, TERMINAL POST, TH, ROHS | KEYSTONE | 1514-2 |
| 5002 | 3 | ea. | P1, P2, P6 | CONN-MINI TEST POINT, VERTICAL, WHITE, ROHS | KEYSTONE | 5002 |
| LTST-C170CKT | 1 | ea. | D1 | LED-GaAs RED, SMD, 2x1.25mm, 100mW, 40mA, 10mcd, ROHS | LITEON/VISHAY | LTST-C170CKT |
| ISL8025 | 1 | ea. | U1 | IC-5A BUCK REGULATOR, 16P, QFN, 3x3, ROHS | INTERSIL | ISL8025 |
| 2N7002-7-F-T | 1 | ea. | Q1 | TRANSISTOR, N-CHANNEL, 3 LD, SOT-23, 60V, 115mA, ROHS | DIODES, INC. | 2N7002-7-F |
| H2505-DNP | 0 | ea. | R11 (ISL8025) | RES, SMD, 0603, 0.1%, MF, DNP-PLACE HOLDER | | |
| H2511-00R00-1/16W | 1 | ea. | R11 (ISL8025A) | RES, SMD, 0603, 0Ω, 1/16W, 1%, TF, ROHS | GENERIC | |
| H2511-00200-1/10W1-T | 1 | ea. | R3 | RES, SMD, 0603, 20Ω, 1/10W, 1%, TF, ROHS | PANASONIC | ERJ-3EKF20R0V |
| H2511-00100-1/16W5 | 1 | ea. | R10 | RES, SM, 0603, 10Ω, 1/16W, 5%, TF, ROHS | GENERIC | |
| H2511-01003-1/10W1-T | 1 | ea. | R2, R14 | RES, SMD, 0603, 100k, 1/10W, 1%, TF, ROHS | VENKEL | CR0603-10W-1003FT |
| H2511-01913-1/10W1-T | 1 | ea. | R12 (ISL8025) | RES, SMD, 0603, 191k, 1/10W, 1%. TF, ROHS | VENKEL | CR-0603-10W-1913FT |
| H2505-DNP | 1 | ea. | R12 (ISL8025A) | RES, SMD, 0603, 0.1%, MF, DNP-PLACE HOLDER | | |
| H2511-02003-1/10W1-T | 4 | ea. | R1, R4, R6, R7 | RES, SMD, 0603, 200k, 1/10W, 1%, TF, ROHS | VENKEL | CR0603-10W-2003FT |
| H2511-DNP | 0 | ea. | R5, R8, R9 | RES, SMD, 0603, DNP-PLACE HOLDER, ROHS | | |
| GT11MSCBE-T | 2 | ea. | SW1, SW2 | SWITCH-TOGGLE, SMD, 6 PIN, SPDT, 2POS, ON-ON, ROHS | ITT INDUSTRIES/C&K DIVISION | GT11MSCBE |
| 5X8-STATIC-BAG | 1 | ea. | Place assy in bag | BAG, STATIC, 5x8, ZIPLOC, ROHS | INTERSIL | 212403-013 |
| LABEL-SERIAL NUMBER | 1 | ea. | | LABEL-FOR SERIAL NUMBER AND BOM REV # | INTERSIL | LABEL-SERIAL NUMBER |

ISL8025xEVAL3Z Board Layout

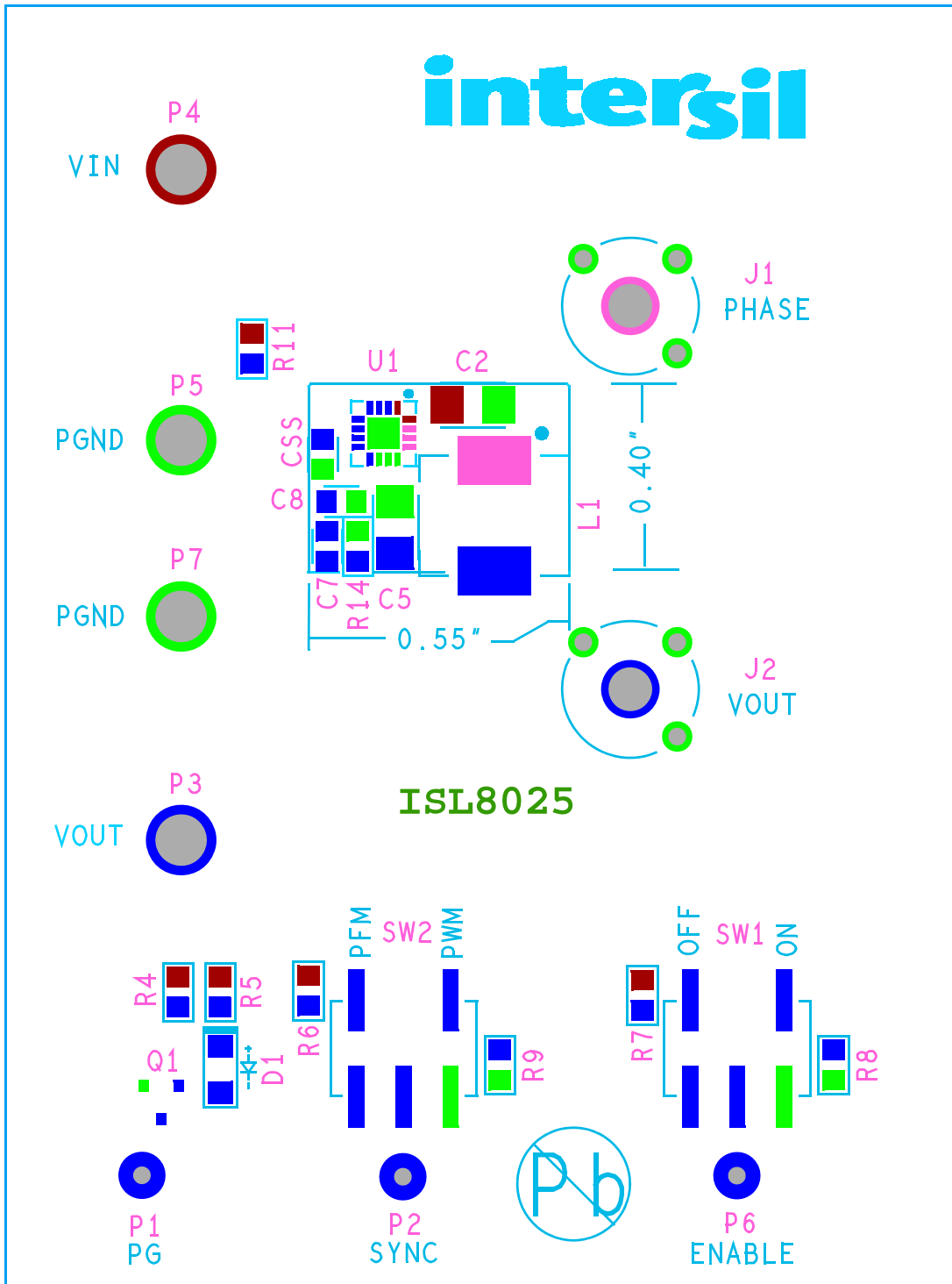

FIGURE 3. TOP LAYER COMPONENTS

ISL8025xEVAL3Z Board Layout (Continued)

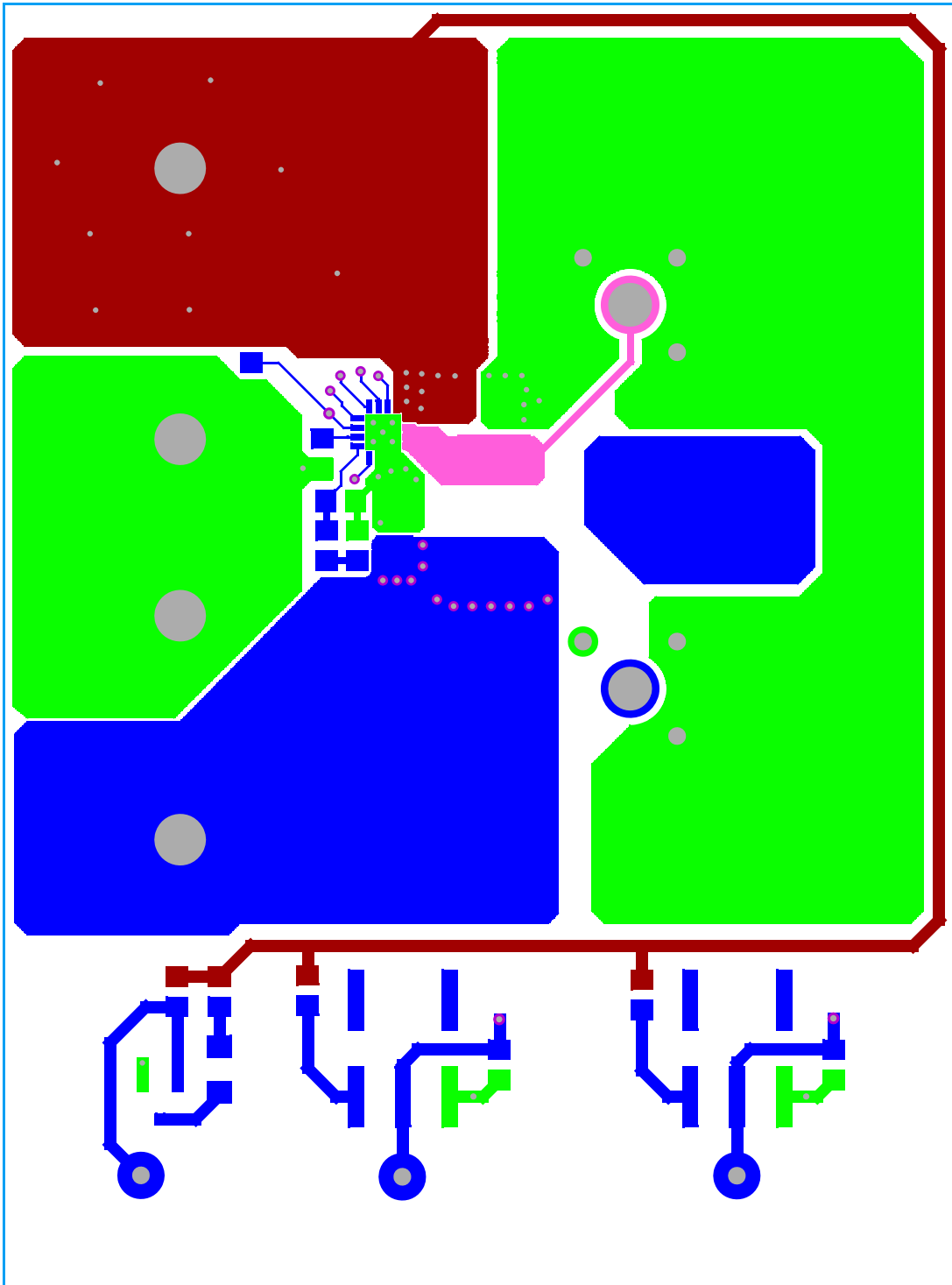

FIGURE 4. TOP LAYER ETCH

ISL8025xEVAL3Z Board Layout (Continued)

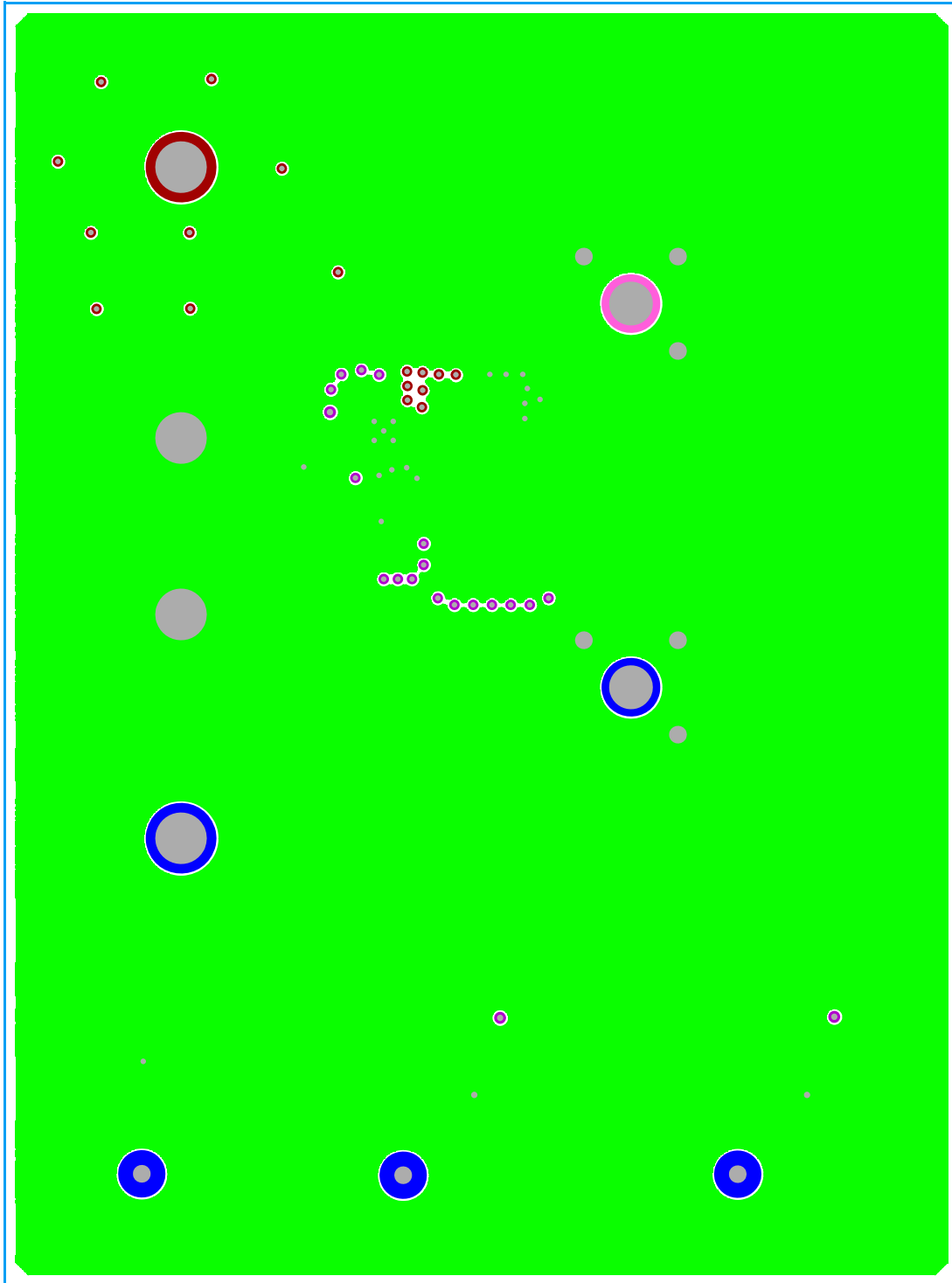

FIGURE 5. SECOND LAYER ETCH

ISL8025xEVAL3Z Board Layout (Continued)

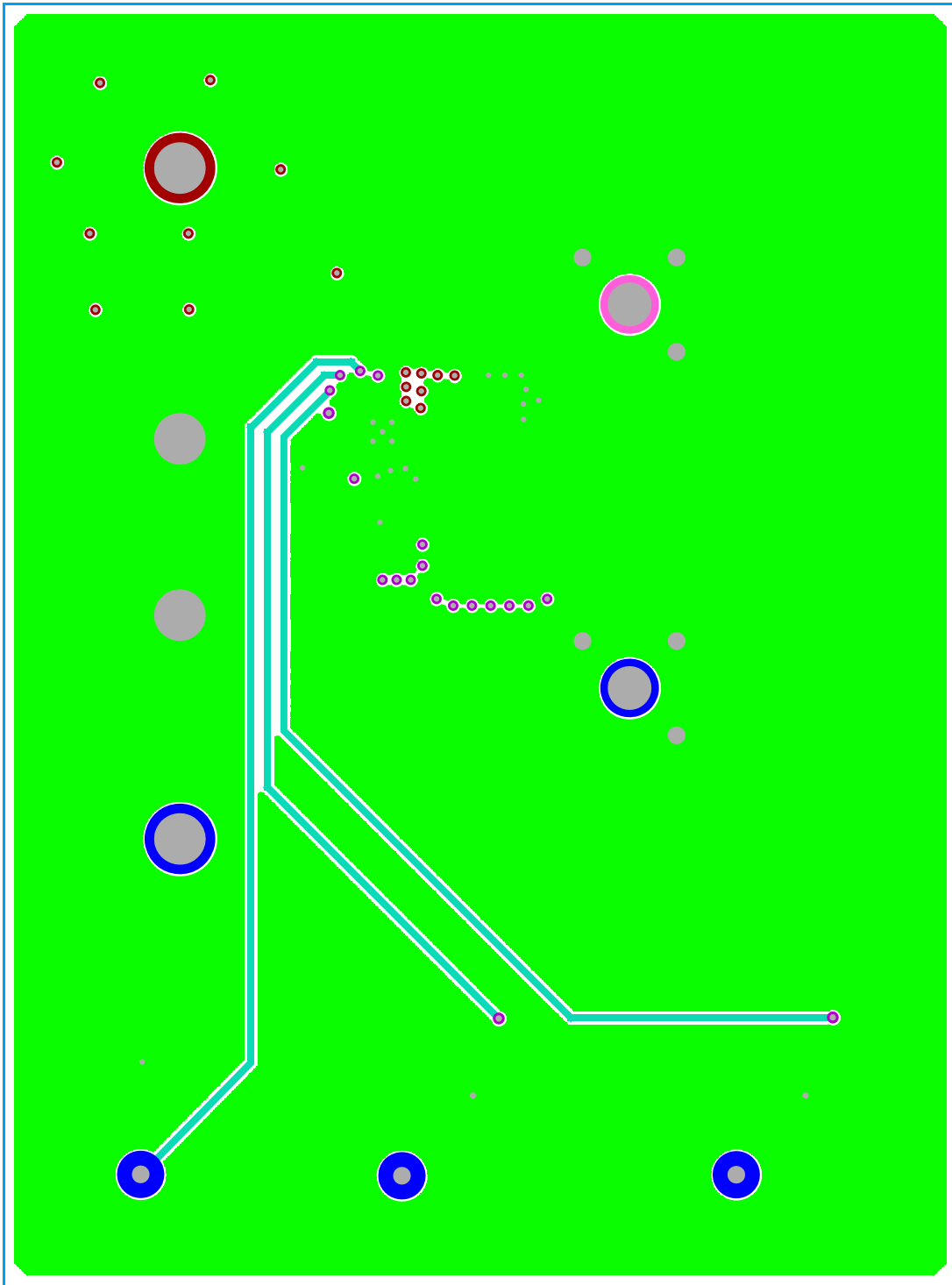

FIGURE 6. THIRD LAYER ETCH

ISL8025xEVAL3Z Board Layout (Continued)

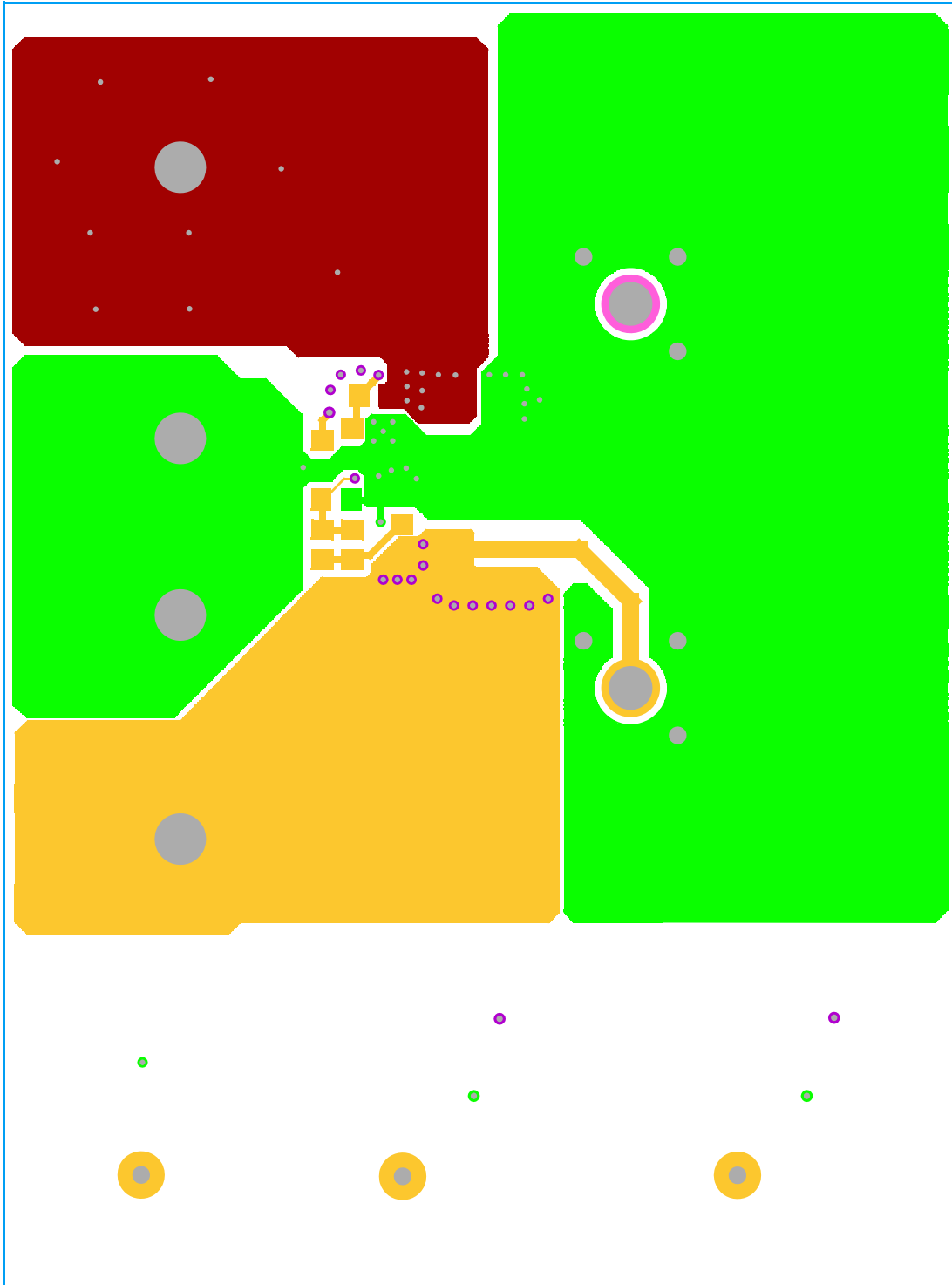

FIGURE 7. BOTTOM LAYER ETCH

ISL8025xEVAL3Z Board Layout (Continued)

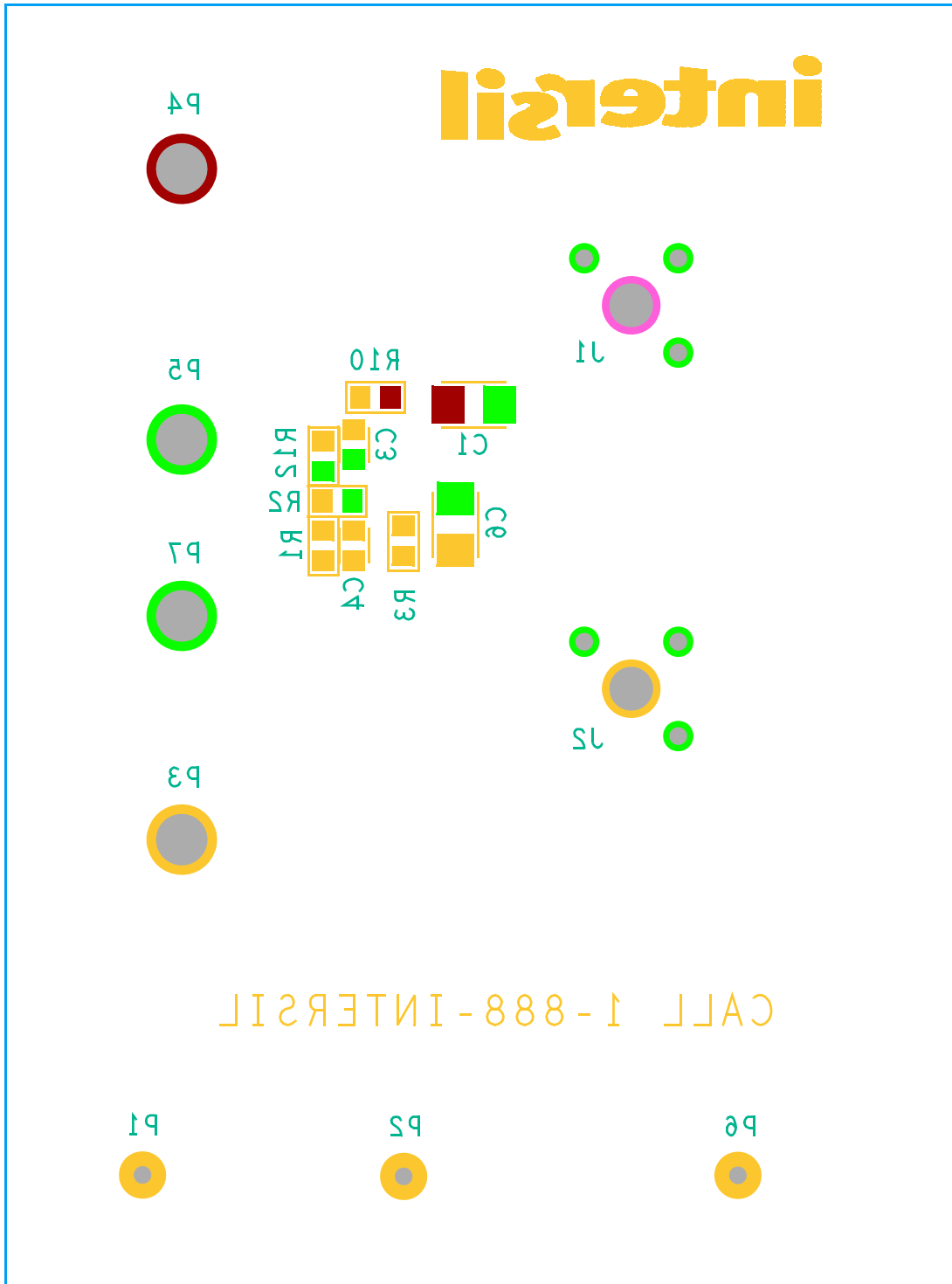

FIGURE 8. BOTTOM LAYER COMPONENTS