

ISL8026xEVAL3Z

Evaluation Board

UG033
Rev 1.00
July 15, 2016

Description

The ISL8026EVAL3Z and ISL8026AEVAL3Z are intended for use by customers with requirements for point-of-load applications sourcing from 2.5V to 5.5V. The ISL8026EVAL3Z and ISL8026AEVAL3Z are used to demonstrate the performance of the [ISL8026](#) and [ISL8026A](#), low quiescent high efficiency synchronous buck regulators.

The ISL8026 and ISL8026A are offered in a 3mmx3mm 16 Ld TQFN package with 1mm maximum height. The complete area that the converter occupies can be as small as 141.935mm².

Specifications

PART NUMBER	I _{OUT} (MAX) (A)	f _{SW} RANGE (MHz)	V _{IN} RANGE (V)	V _{OUT} RANGE (V)	PART SIZE (2mm)
ISL8026	6	Programmable 0.5 to 4	2.5 to 5.5	0.6 to 5.5	3x3
ISL8026A		Programmable 1 to 4			

NOTES:

- The evaluation boards' default configuration are V_{OUT} = 1.8V for ISL8026EVAL3Z (f_{SW} = 1MHz) and ISL8026AEVAL3Z (f_{SW} = 2MHz).
- V_{REF} is 0.6V.

Key Features

- High efficiency synchronous buck regulator with up to 95% efficiency
- 1% reference accuracy over load/line/temperature (-40 °C to +85 °C)
- Start-up with prebiased output
- Internal soft-start - 1ms or adjustable
- Soft-stop output discharge during disabled
- Adjustable frequency from 500kHz to 4MHz - default at 1MHz (2MHz for ISL8026A)
- External synchronization up to 4MHz
- Negative OC protection

References

[ISL8026](#), [ISL8026A](#) Datasheet

Ordering Information

PART NUMBER	DESCRIPTION
ISL8026EVAL3Z	Evaluation Board For ISL8026
ISL8026AEVAL3Z	Evaluation Board For ISL8026A

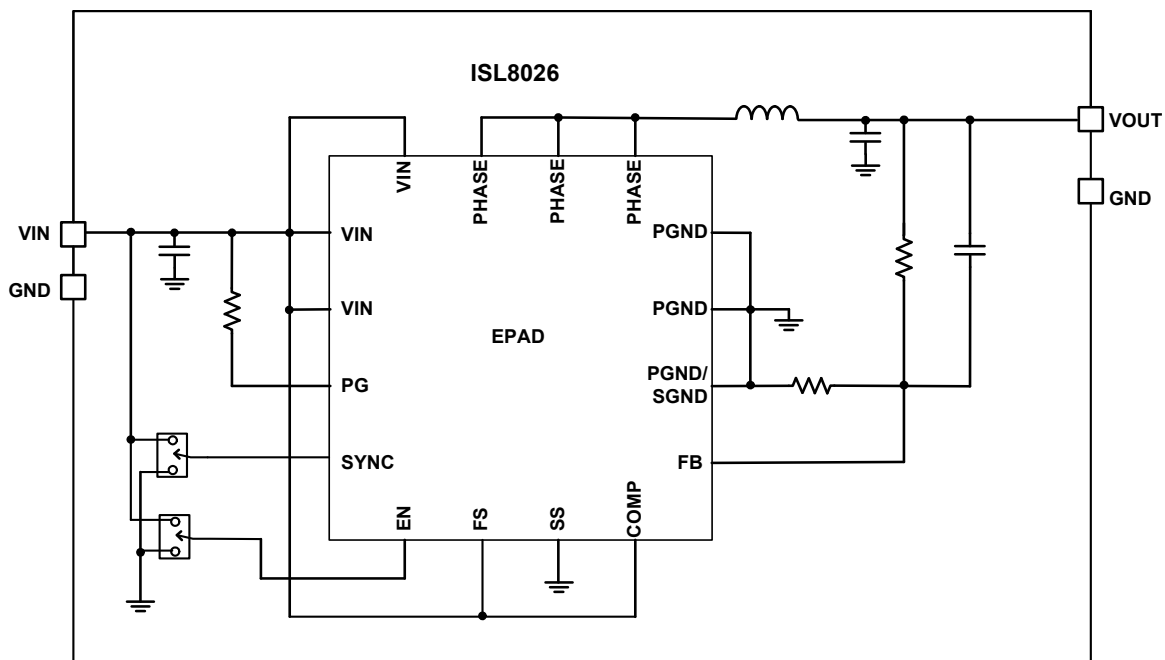

FIGURE 1. BLOCK DIAGRAM



FIGURE 2. ISL8026EVAL3Z



FIGURE 3. ISL8026AEVAL3Z

Recommended Equipment

The following materials are recommended to perform testing:

- 0V to 10V power supply with at least 10A source current capability or 5V battery
- Electronic loads capable of sinking current up to 7A
- Digital Multimeters (DMMs)
- 100MHz quad-trace oscilloscope
- Signal generator

Quick Setup Guide

1. Ensure that the circuit is correctly connected to the supply and loads prior to applying any power.
2. Connect the bias supply to V_{IN} , the plus terminal to V_{IN} , P4 and the negative return to PGND, P5.
3. Connect the output load to V_{OUT} , the plus terminal to V_{OUT} , P3 and the negative return to PGND, P7.
4. Verify that the position is set to PWM for SW2.
5. Verify that the position is set to ON for SW1.
6. Turn on the power supply.
7. Verify that the output voltage is 1.8V for V_{OUT} .

Operating Range

By default, the ISL8026EVAL3Z is configured for the operating conditions shown in the “Quick Setup Guide”. The board can also support a wider operating range. Modifying the operating conditions will change the performance results.

The ISL8026EVAL3Z and ISL8026AEVAL3Z outputs are preset to 1.8V for V_{OUT} , however, output voltages can be adjusted from 0.6V to 5V. The output voltage programming resistor, R_1 , will depend on the desired output voltage of the regulator. The value for the feedback resistor is typically between 0Ω and $200k\Omega$, as shown in [Equation 1](#).

$$R_2 = R_1 \left(\frac{V_{FB}}{V_O - V_{FB}} \right) \quad (\text{EQ. 1})$$

If the output voltage desired is 0.6V, then R_2 is left unpopulated and R_1 is shorted. For faster response performance, add 10pF to 47pF in parallel to R_1 . Check the Bode plot to insure optimum performance.

Frequency Control

The ISL8026 and ISL8026A have an FS pin that controls the frequency of operation. Programmable frequency allows for optimization between efficiency and external component size. Default switching frequency is 1MHz for ISL8026EVAL3Z and 2MHz for ISL8026AEVAL3Z when FS is tied to V_{IN} ($R_{11} = 0$ and R_{12} is open). By changing the value of R_{12} , the switching frequency can be changed from 500kHz to 4MHz according to [Equation 2](#):

$$R_T[k\Omega] = \frac{220 \cdot 10^3}{f_{OSC}[kHz]} - 14 \quad (\text{EQ. 2})$$

When using R_{12} to adjust the operational frequency, this also sets the external compensation mode. Please refer to the [ISL8026](#), [ISL8026A](#) datasheet for more details.

Soft-Start Control

Short CSS to SGND for internal soft-start (approximately 1ms). Populate CSS to adjust the soft-start time. This capacitor, along with an internal 1.6μA current source, sets the soft-start interval of the converter, t_{SS} .

$$C_{SS}[\mu F] = 3.33 \cdot t_{SS}[s] \quad (\text{EQ. 3})$$

CSS must be less than 33nF to insure proper soft-start reset after a fault condition.

Switches Control

The ISL8026EVAL3Z and ISL8026AEVAL3Z boards contain SW1 and SW2 for various controls of the ISL8026, ISL8026A circuitries. [Table 1](#) details this function.

TABLE 1. SWITCH SETTINGS

SW1	ENABLE	FUNCTION
1	OFF	DISABLE VO
3	ON	ENABLE VO
SW2	MODE	FUNCTION
1	PWM	Fixed PWM frequency at light load
3	PFM	Force continuous mode

PCB Layout Recommendation

The PCB layout is a very important converter design step to make sure the designed converter works well. For ISL8026, ISL8026A, the power loop is composed of the output inductor L's, the output capacitor (COUT), the PHASE pins and the PGND pin. It is necessary to make the power loop as small as possible and the connecting traces among them should be direct, short and wide. The switching node of the converter, the PHASE pins and the traces connected to the node are very noisy, so keep the voltage feedback trace away from these noisy traces. The input capacitor should be placed as close as possible to the VIN pin. The ground of input and output capacitors should be connected as close as possible. The heat of the IC is mainly dissipated through the thermal pad. Maximizing the copper area connected to the thermal pad is preferable. In addition, a solid ground plane is helpful for better EMI performance. It is recommended to add at least 5 vias ground connection within the pad for the best thermal relief.

ISL8026xEVAL3Z Schematic

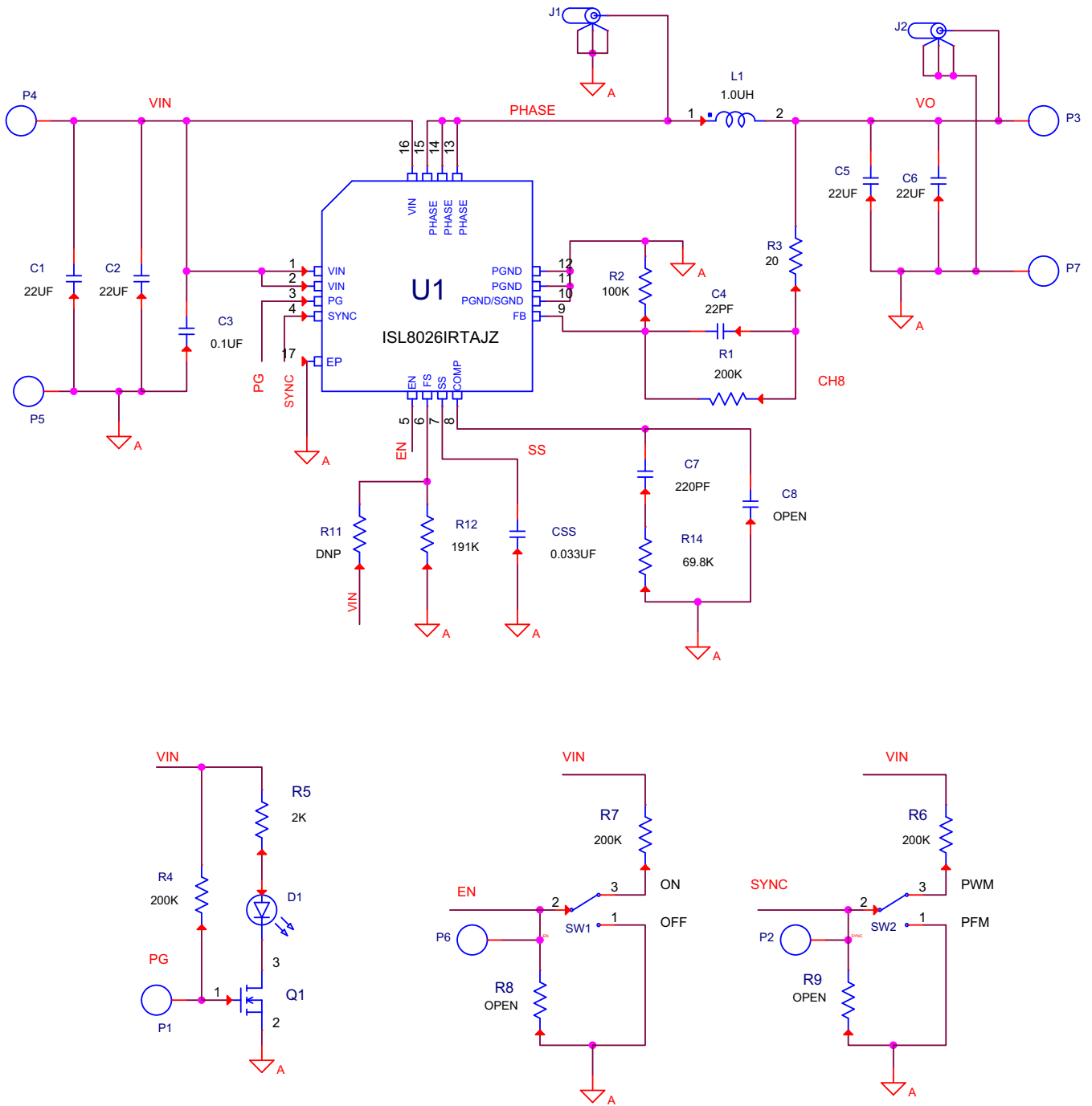

FIGURE 4. SCHEMATIC

Bill Of Materials

QTY	UNIT	REFERENCE DESIGNATOR	DESCRIPTION	MANUFACTURER	MANUFACTURER PART
1	ea.		PWB-PCB, ISL8026, REVA, ROHS	IMAGINEERING INC	ISL8026REVAPCB
1	ea.	C4	CAP, SMD, 0603, 22pF, 50V, 5%, COG, ROHS	VENKEL	C0603C0G500-220JNE
1	ea.	C7	CAP, SMD, 0603, 220pF, 50V, 10%, X7R, ROHS	MURATA	GRM188R71H221KA01D
1	ea.	CSS	CAP, SMD, 0603, 33000pF, 16V, 10%, X7R, ROHS	VENKEL	C0603X7R160-333KNE
1	ea.	C3	CAP, SMD, 0603, 0.1μF, 16V, 10%, X7R, ROHS	VENKEL	C0603X7R160-104KNE
0	ea.	C8	CAP, SMD, 0603, DNP-PLACE HOLDER, ROHS		
4	ea.	C1, C2, C5, C6	CAP, SMD, 1206, 22μF, 6.3V, 10%, X5R, ROHS	MURATA	GRM31CR60J226KE19L
1	ea.	L1 (ISL8026)	1μH, 6.9mΩ, 8.1A, ROHS, SHIELDED	PANASONIC (Note 3)	ETQP3W1ROWFN
				TDK (Note 3)	SPM6530T-1R0M120
1	ea.	L1 (ISL8026A)	0.68μH, 4.9mΩ, 9.6A, ROHS, SHIELDED	PANASONIC (Note 3)	ETQP3WR68WFN
				TDK (Note 3)	SPM6530T-R68M140
2	ea.	J1, J2	CONN-SCOPE PROBE TEST PT, COMPACT, PCB MNT, ROHS	TEKTRONIX	131-4353-00
4	ea.	P4, P5, P7, P8	CONN-TURRET, TERMINAL POST, TH, ROHS	KEYSTONE	1514-2
3	ea.	P1, P2, P6	CONN-MINI TEST POINT, VERTICAL, WHITE, ROHS	KEYSTONE	5002
1	ea.	D1	LED-GaAs RED, SMD, 2x1.25mm, 100mW, 40mA, 10mcd, ROHS	LITEON/VISHAY	LTST-C170CKT
1	ea.	U1	IC-5A BUCK REGULATOR, 16P, QFN, 3x3, ROHS	INTERSIL	ISL8026
1	ea.	Q1	TRANSISTOR, N-CHANNEL, 3 LD, SOT-23, 60V, 115mA, ROHS	DIODES, INC.	2N7002-7-F
0	ea.	R11 (ISL8026)	RES, SMD, 0603, 0.1%, MF, DNP-PLACE HOLDER		
1	ea.	R11 (ISL8026A)	RES, SMD, 0603, 0Ω, 1/16W, 1%, TF, ROHS	GENERIC	
1	ea.	R3	RES, SMD, 0603, 20Ω, 1/10W, 1%, TF, ROHS	PANASONIC	ERJ-3EKF20R0V
1	ea.	R2, R14	RES, SMD, 0603, 100k, 1/10W, 1%, TF, ROHS	VENKEL	CR0603-10W-1003FT
1	ea.	R12 (ISL8026)	RES, SMD, 0603, 191k, 1/10W, 1%, TF, ROHS	VENKEL	CR-0603-10W-1913FT
1	ea.	R12 (ISL8026A)	RES, SMD, 0603, 0.1%, MF, DNP-PLACE HOLDER		
4	ea.	R1, R4, R6, R7	RES, SMD, 0603, 200k, 1/10W, 1%, TF, ROHS	VENKEL	CR0603-10W-2003FT
0	ea.	R5, R8, R9	RES, SMD, 0603, DNP-PLACE HOLDER, ROHS		
2	ea.	SW1, SW2	SWITCH-TOGGLE, SMD, 6 PIN, SPDT, 2POS, ON-ON, ROHS	ITT INDUSTRIES/ C&K DIVISION	GT11MSCBE

NOTE:

3. Two manufacturers are provided as options for the inductor.

ISL8026xEVAL3Z Board Layout

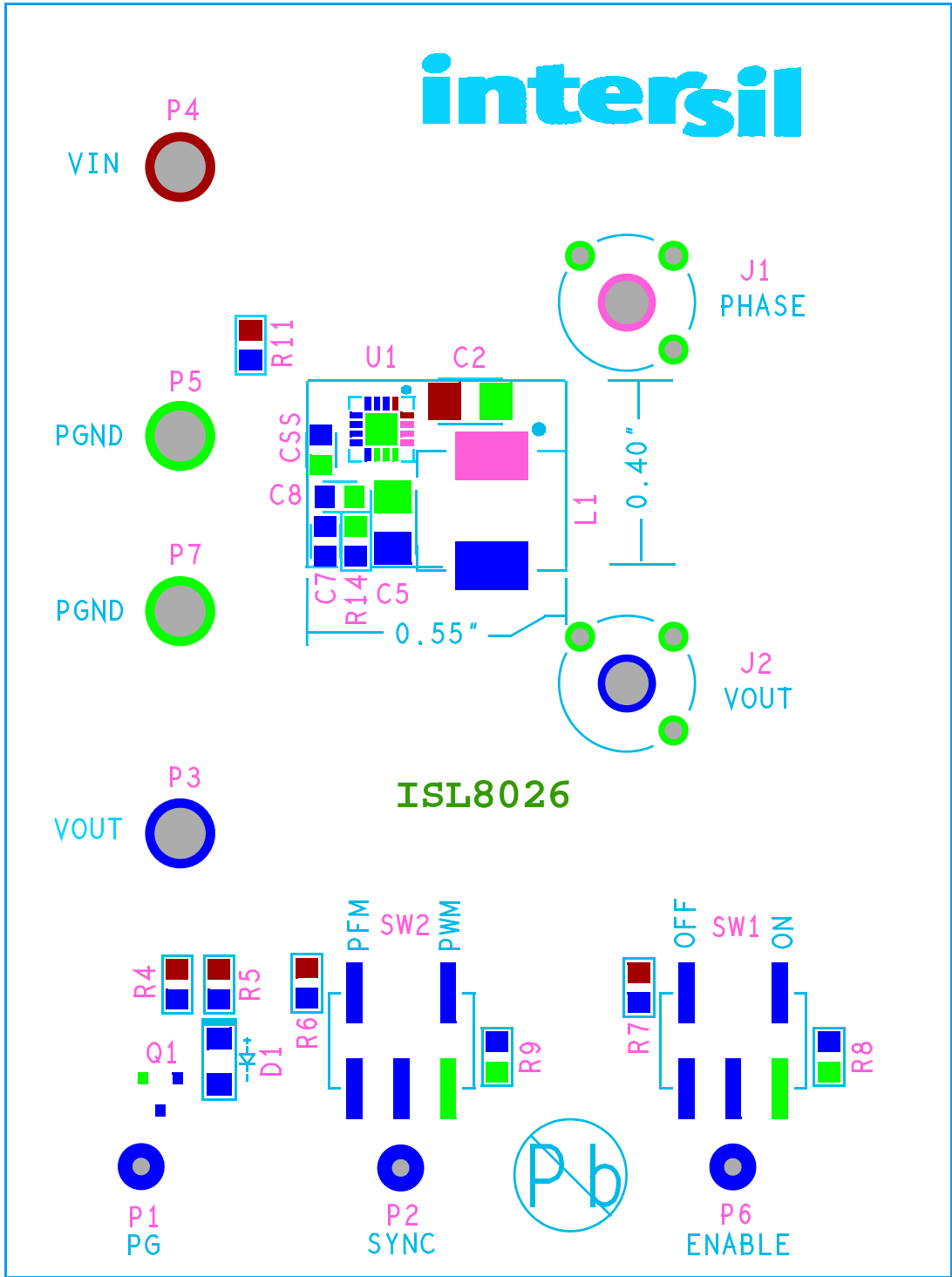

FIGURE 5. TOP LAYER COMPONENTS

ISL8026xEVAL3Z Board Layout (Continued)

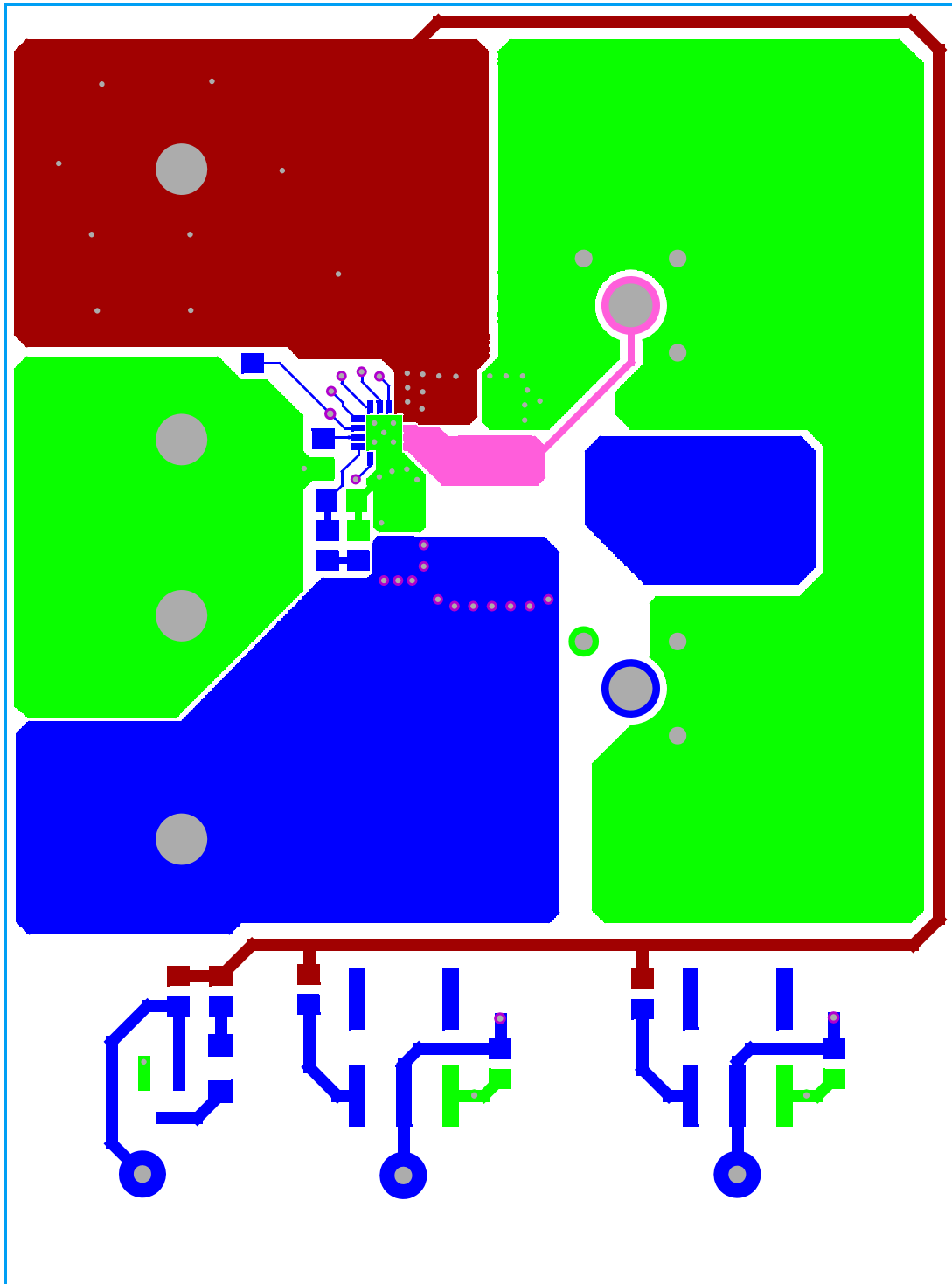

FIGURE 6. TOP LAYER ETCH

ISL8026xEVAL3Z Board Layout (Continued)

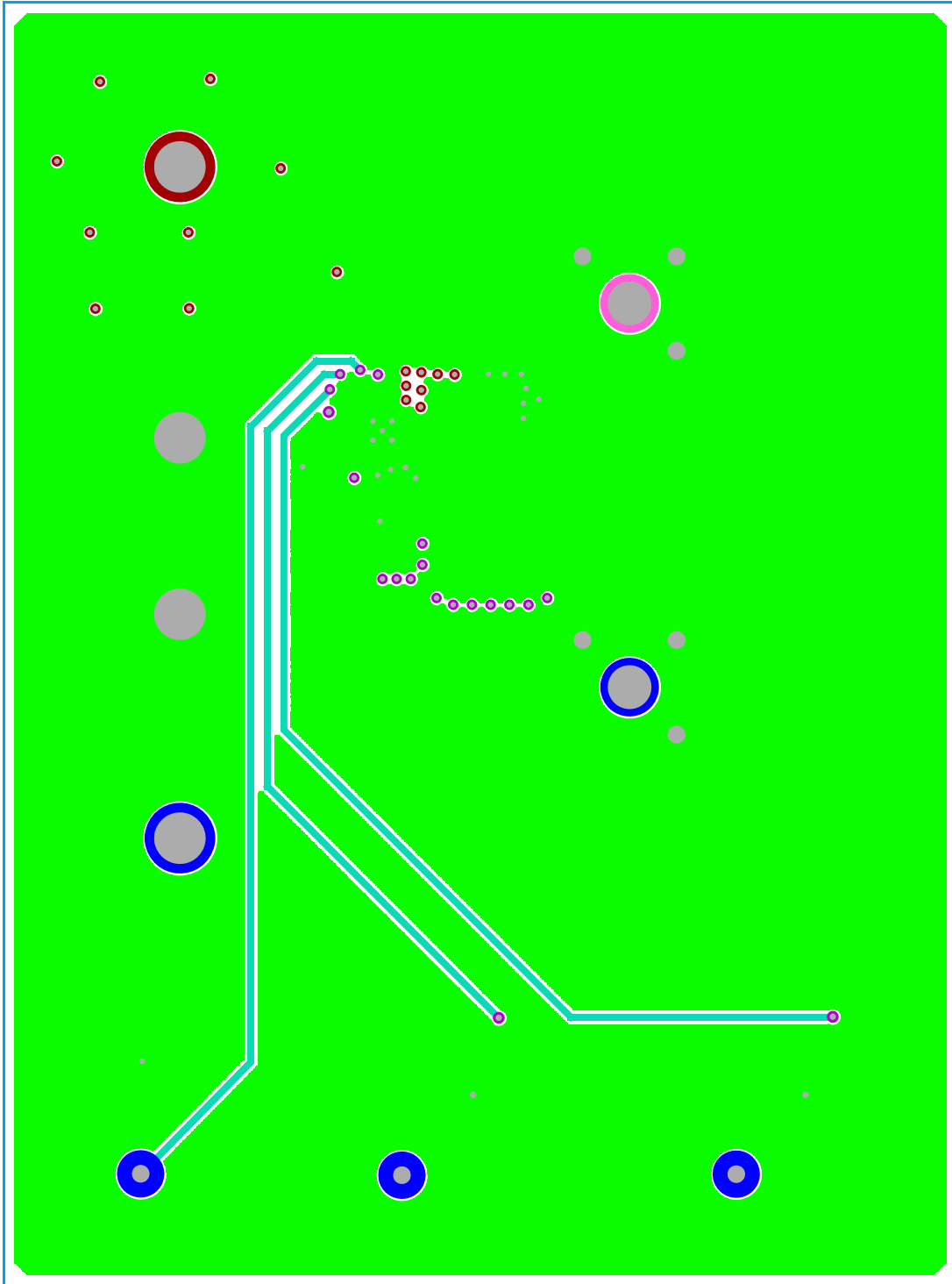

FIGURE 8. THIRD LAYER ETCH

ISL8026xEVAL3Z Board Layout (Continued)

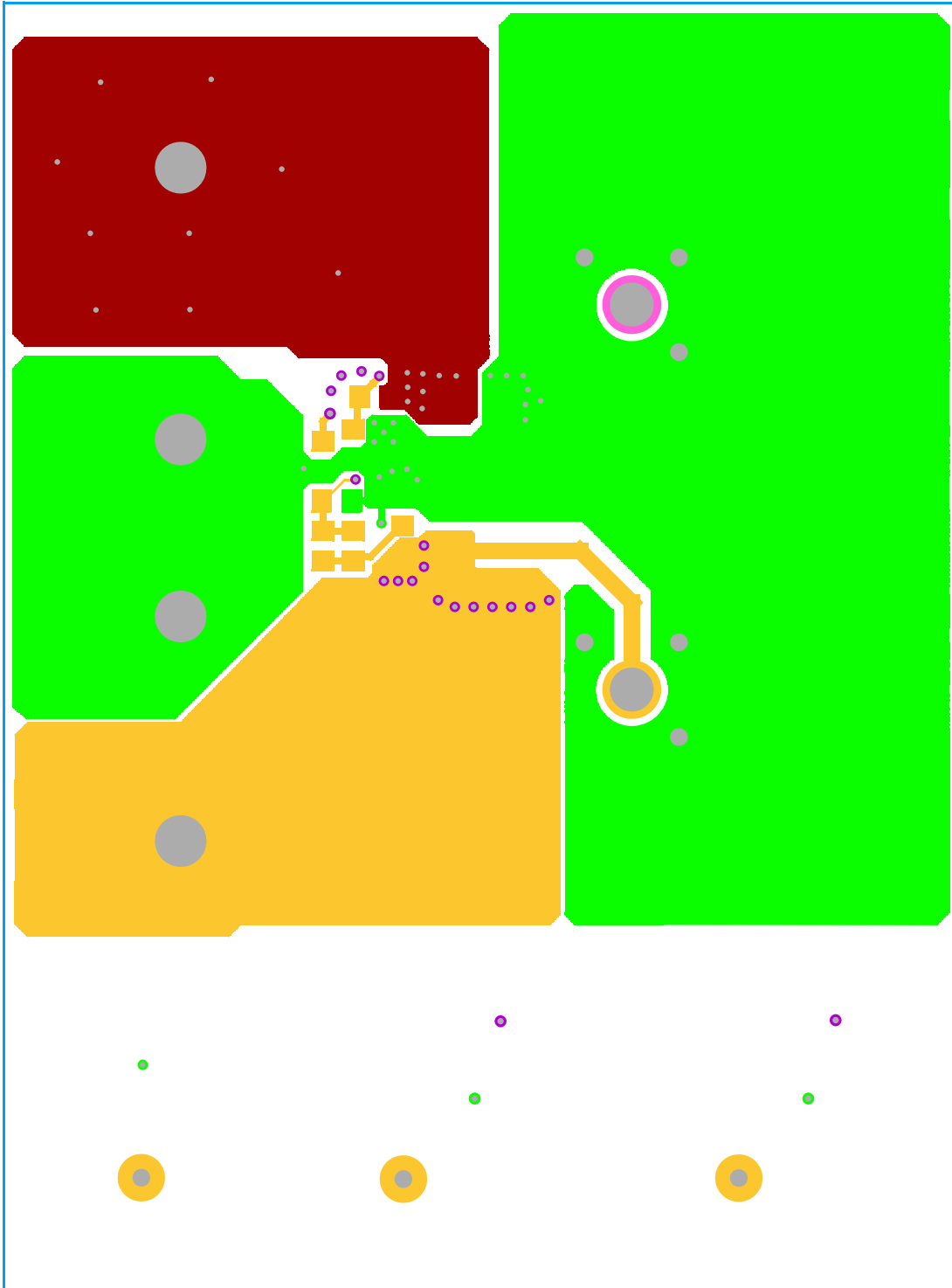

FIGURE 9. BOTTOM LAYER ETCH

ISL8026xEVAL3Z Board Layout (Continued)

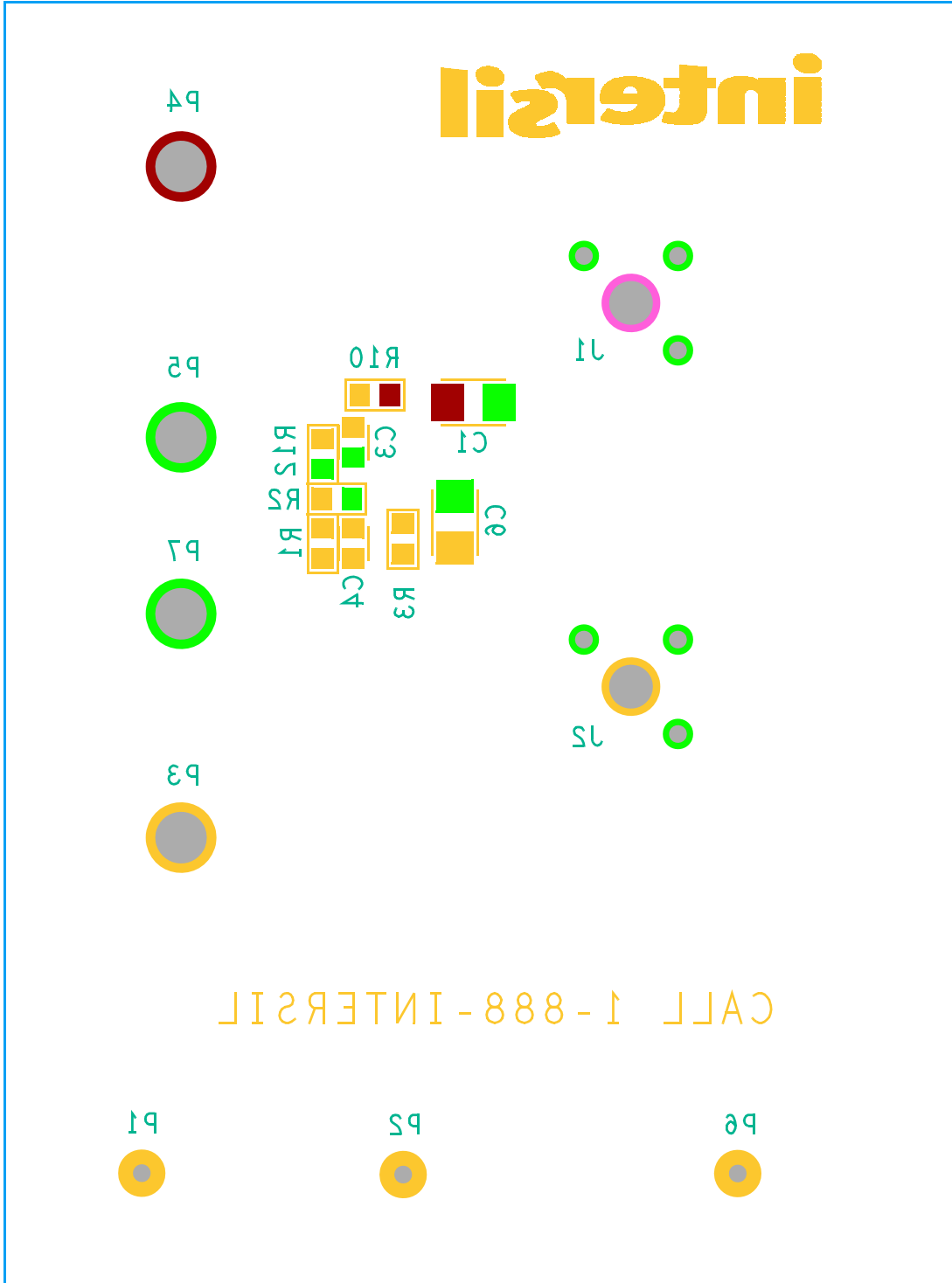

FIGURE 10. BOTTOM LAYER COMPONENTS

Typical Performance Curves

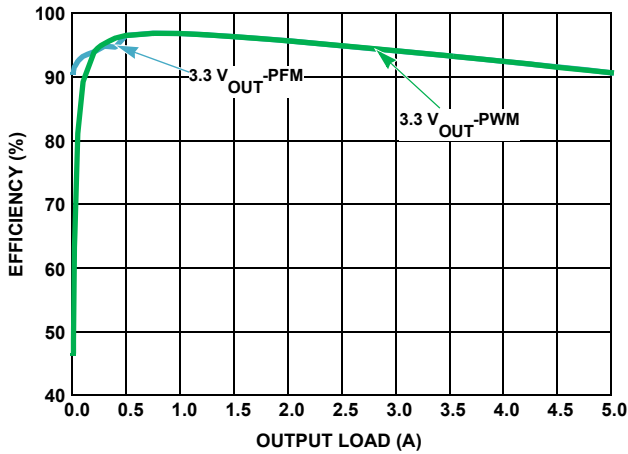

FIGURE 11. EFFICIENCY vs LOAD (1MHz 5V_{IN})

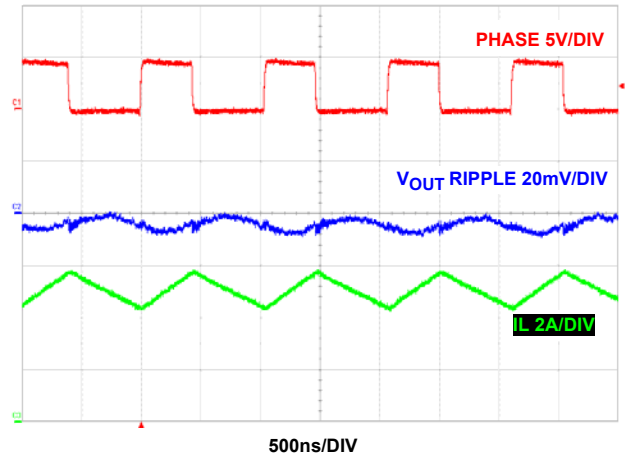

FIGURE 12. STEADY STATE AT 5A PWM

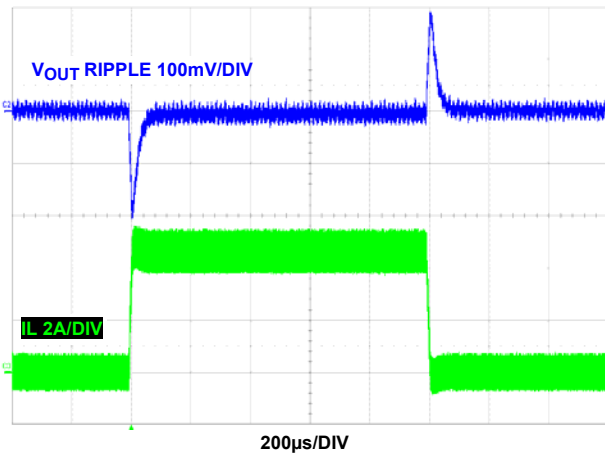

FIGURE 13. LOAD TRANSIENT (PWM)

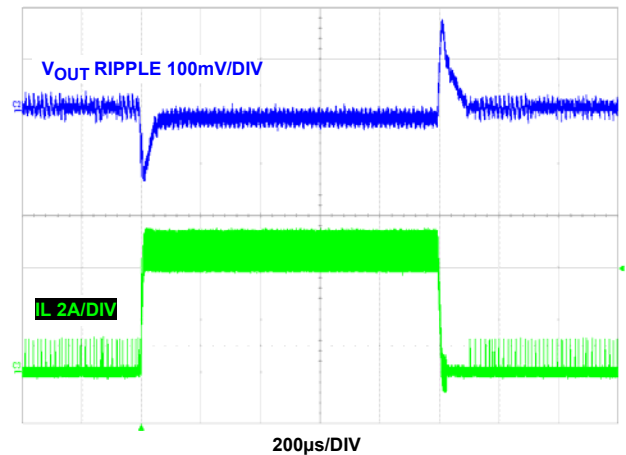

FIGURE 14. LOAD TRANSIENT (PFM)