

## ISL8033EVAL1Z, ISL8033AEVAL1Z

Dual 3A Low Quiescent Current High Efficiency Synchronous Buck Regulator

AN1606  
Rev 1.00  
May 12, 2016

### Description

The ISL8033EVAL1Z, ISL8033AEVAL1Z evaluation boards are intended for use by individuals with requirements for point of load applications sourcing from 2.85V to 6V. The ISL8033EVAL1Z and ISL8033AEVAL1Z boards are used to demonstrate the performance of the ISL8033 and ISL8033A low quiescent current mode converters.

The [ISL8033](#) and [ISL8033A](#) are offered in a 4mmx4mm 24 Ld QFN package with 1mm maximum height. The complete converter occupies less than 5.46cm<sup>2</sup> area.

### Key Features

- Dual 3A high efficiency synchronous buck regulator with up to 95% efficiency
- 180° out-of-phase
- Power-Good (PG) output with 1ms delay
- 2.85V to 6V supply voltage
- 2% output accuracy over temperature/load/line
- Start-up with pre-biased output
- Internal digital soft-start - 1.5ms
- Soft-stop output discharge during disabled
- External synchronization up to 6MHz
- Typical 8µA logic controlled shutdown current
- 100% maximum duty cycle for lowest dropout
- Internal current mode compensation
- Peak current limiting, hiccup mode short-circuit protection and over-temperature protection
- Negative current detection and protection

### Recommended Equipment

The following materials are recommended to perform testing:

- 0V to 10V power supply with at least 3A source current capability or 5V battery
- Electronic loads capable of sinking current up to 3A
- Digital Multimeters (DMMs)
- 100MHz quad-trace oscilloscope
- Signal generator

### Quick Setup Guide

1. Ensure that the circuit is correctly connected to the supply and loads prior to applying any power.
2. Connect the bias supply to  $V_{IN1}$ , the plus terminal to  $V_{IN1}$  and the negative return to PGND1.
3. Verify that position is ON for SW2 and SW3.
4. Turn on the power supply.
5. Verify the output voltage is 1.8V for  $V_{OUT1}$  and 1.8V for  $V_{OUT2}$ .

### Evaluating the Other Output Voltage

The ISL8033EVAL1Z and ISL8033AEVAL1Z outputs are preset to 1.8V for  $V_{OUT1}$  and 1.8V for  $V_{OUT2}$ ; however, output voltages can be adjusted from 0.8V to 3.3V. The output voltage programming resistor,  $R_2$  (or  $R_5$  in Channel 2), will depend on the desired output voltage of the regulator. The value for the feedback resistor is typically between 0Ω and 750kΩ as shown in [Equation 1](#).

Let's set  $R_3/R_6 = 100k\Omega$  then  $R_2/R_5$  will be:

$$R_2 = R_3 \left( \frac{V_{OUT}}{V_{FB}} - 1 \right) \quad (EQ. 1)$$

If the output voltage desired is 0.8V, then leave  $R_3$  unpopulated and short  $R_2$ . For faster response performance, add 47pF in parallel to  $R_2$ .

### Mode Control

The ISL8033 and ISL8033A have a SYNC pin. Connect to logic high or input voltage  $V_{IN}$  for PWM internal synchronization. Connect to an external function generator for external synchronization. Negative edge trigger. Do not leave this pin floating. Do not tie this pin low (or to GND).

TABLE 1. SWITCH SETTINGS

SW2, SW3	ENABLE	ON/OFF CONTROL
1	OFF	Disable $V_{OUT}$
3	ON	Enable $V_{OUT}$

### Ordering Information

PART NUMBER	DESCRIPTION
ISL8033EVAL1Z	Dual 1MHz, 3A per channel non-current sharing regulator evaluation board
ISL8033AEVAL1Z	Dual 2.25MHz, 3A per channel non-current sharing regulator evaluation board

# ISL8033EVAL1Z, ISL8033AEVAL1Z Schematics

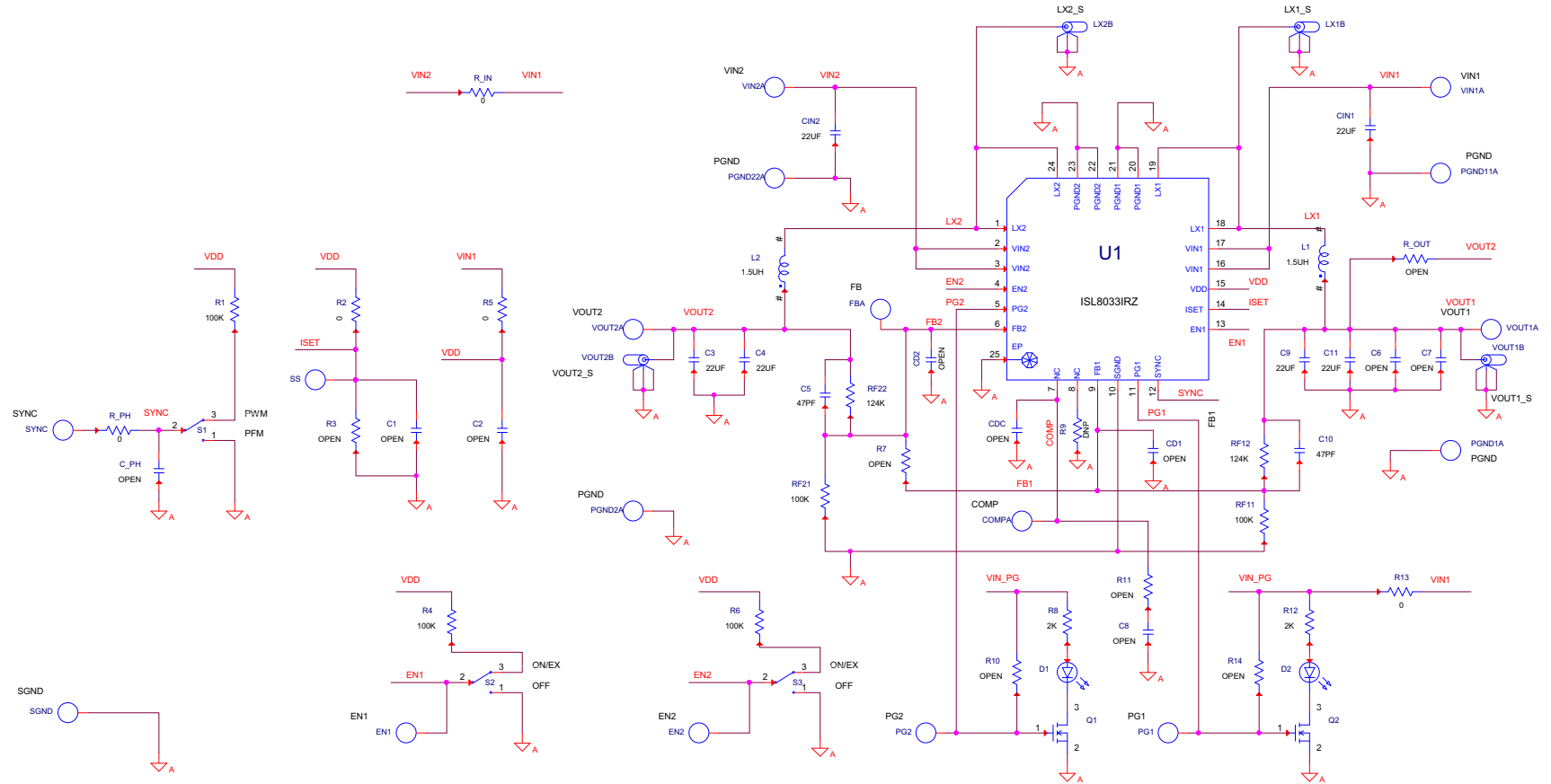

**NOTE:**

- PLEASE KEEP FB1, FB2 PINS TRACES SHORT
- PLEASE KEEP COMP PIN TRACES SHORT (TO C8, R13)

**FIGURE 1. ISL8033EVAL1Z SCHEMATIC**

# ISL8033EVAL1Z, ISL8033AEVAL1Z Schematics (Continued)

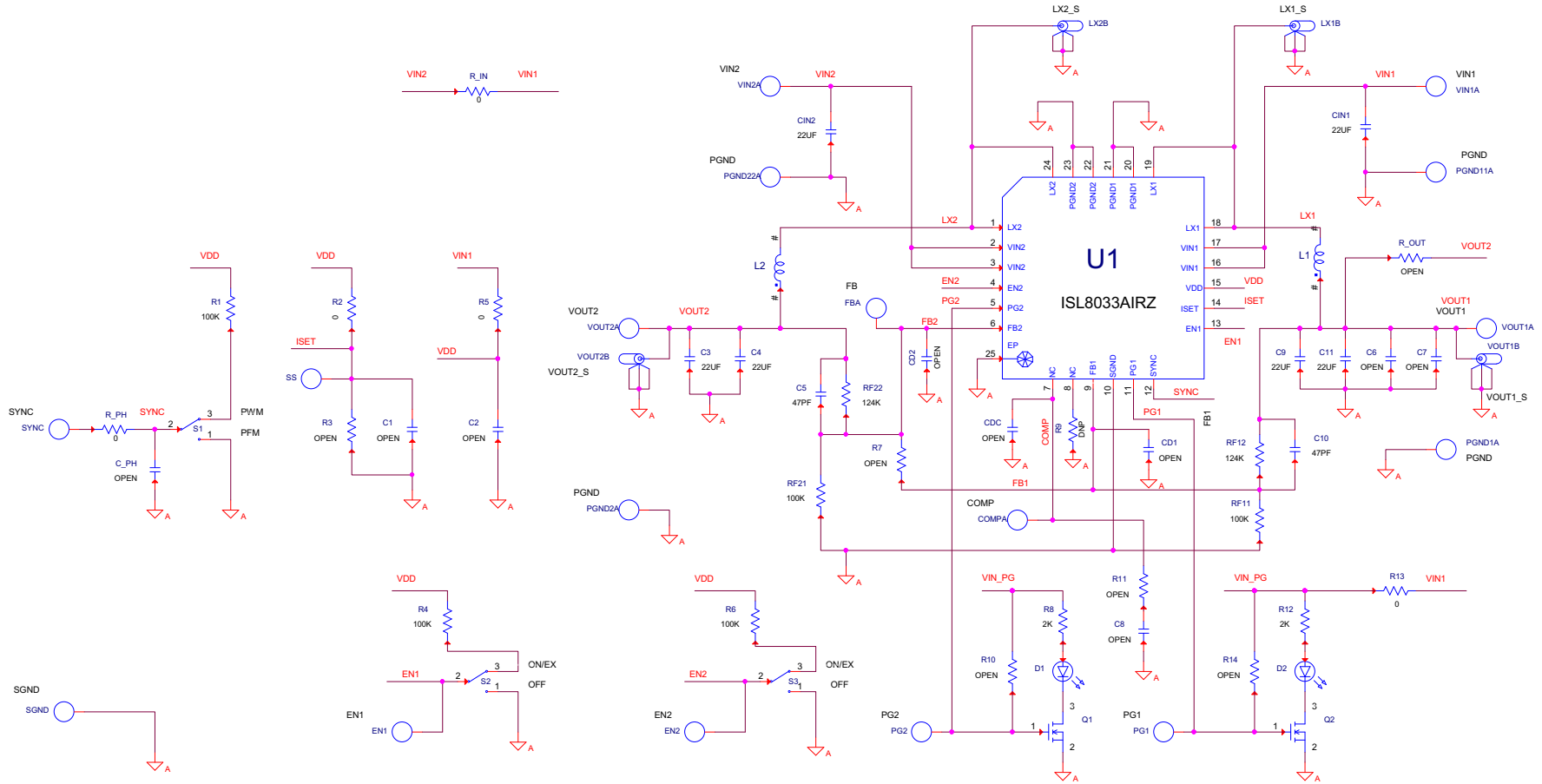

**NOTE:**

- PLEASE KEEP FB1, FB2 PINS TRACES SHORT
- PLEASE KEEP COMP PIN TRACES SHORT (TO C8, R13)

**FIGURE 2. ISL8033AEVAL1Z SCHEMATIC**

TABLE 2. BILL OF MATERIALS

PART NUMBER	QTY	UNITS	REFERENCE DESIGNATOR	DESCRIPTION	MANUFACTURER	MANUFACTURER PART
ISL8033_36EVAL1ZREVAPCB	1	ea.	a) PUT "X" IN ISL8033 BOX ON PCB	PWB-PCB, ISL8033_36EVAL1Z, REVA, ROHS	IMAGINEERING INC.	ISL8033_36EVAL1ZREVAPCB
ISL8033_36EVAL1ZREVAPCB	0	ea.	b) SEE LABEL-RENAME BOARD	PWB-PCB, ISL8033_36EVAL1Z, REVA, ROHS	IMAGINEERING INC.	ISL8033_36EVAL1ZREVAPCB
C2012X5R0J226M-T	6	ea.	C3, C4, C9, C11, CIN1, CIN2	CAP, SMD, 0805, 22µF, 6.3V, 20%, X5R, ROHS	TDK	C2012X5R0J226M
H1045-00120-50V5-T	2	ea.	C5, C10	CAP, SMD, 0603, 12pF, 50V, 5%, COG, ROHS	AVX	06035A120JAT2A
H1045-DNP	0	ea.	C1, C2, C8, CD1, CD2, CDC, C_PH	CAP, SMD, 0603, DNP-PLACE HOLDER, ROHS		
H1046-DNP	0	ea.	C6, C7	CAP, SMD, 0805, DNP-PLACE HOLDER, ROHS		
DR73-1R5-R (ISL8033)	2	ea.	L1, L2	COIL-PWR INDUCTOR, SMD, 7.5mm, 1.5µH, 20%, 6.52A, ROHS	COOPER ELECTRONIC TECH	DR73-1R5-R
FDV0630-R60M (ISL8033A)	2	ea.	L1, L2	Iron Powder Inductor, SMD, 7.4X6.7mm, 0.6µH, 20%, 10A, ROHS	TOKO	FDV0630-R60M
131-4353-00	4	ea.	LX1, LX2, VOUT1_S, VOUT2_S	CONN-SCOPE PROBE TEST PT, COMPACT, PCB MNT, ROHS	TEKTRONIX	131-4353-00
1514-2	8	ea.	a) PGND1, PGND2, PGND11, PGND22, VIN1, VIN2	CONN-TURRET, TERMINAL POST, TH, ROHS	KEYSTONE	1514-2
1514-2	0	ea.	b) VOUT1, VOUT2	CONN-TURRET, TERMINAL POST, TH, ROHS	KEYSTONE	1514-2
5000	6	ea.	a) EN1, EN2, PG1, PG2, SS, SYNC	CONN-MINI TEST PT, VERTICAL, RED, ROHS	KEYSTONE	5000
5000	0	ea.	b) SYNC located left of C_PH	CONN-MINI TEST PT, VERTICAL, RED, ROHS	KEYSTONE	5000
5001	1	ea.	SGND	CONN-MINI TEST PT, VERTICAL, BLK, ROHS	KEYSTONE	5001
5002	2	ea.	COMP, FB	CONN-MINI TEST PT, VERTICAL, WHITE, ROHS	KEYSTONE	5002
LTST-C170CKT	2	ea.	D1, D2	LED-GaAs RED, SMD, 2mmX1.25mm, 100mW, 40mA, 10mcd, ROHS	LITEON/VISHAY	LTST-C170CKT
ISL8033IRZ (ISL8033EVAL1Z)	1	ea.	U1	IC-DUAL 3A BUCK REGULATOR, 24P, QFN, 4X4, ROHS	INTERSIL	ISL8033IRZ
ISL8033AIRZ (ISL8033AEVAL1Z)						
2N7002-7-F-T	2	ea.	Q1, Q2	TRANSISTOR, N-CHANNEL, 3LD, SOT-23, 60V, 115mA, ROHS	DIODES, INC.	2N7002-7-F
H2509-DNP	1	ea.	R9	RES, SMD, 0201, 0Ω, 1/20W, 0%, TF		
H2511-00R00-1/10W-T	4	ea.	R2, R5, R13, R_PH	RES, SMD, 0603, 0Ω, 1/10W, TF, ROHS	VENKEL	CR0603-10W-000T
H2511-01003-1/10W1-T	5	ea.	R1, R4, R6, RF11, RF21	RES, SMD, 0603, 100k, 1/10W, 1%, TF, ROHS		

TABLE 2. BILL OF MATERIALS (Continued)

PART NUMBER	QTY	UNITS	REFERENCE DESIGNATOR	DESCRIPTION	MANUFACTURER	MANUFACTURER PART
H2511-01243-1/10W1-T	2	ea.	RF12, RF22	RES, SMD, 0603, 124k, 1/10W, 1%, TF, ROHS	YAGEO	9C06031A1243FKHFT
H2511-02001-1/10W1-T	2	ea.	R8, R12	RES, SMD, 0603, 2k, 1/10W, 1%, TF, ROHS	KOA	RK73H1JTTD2001F
H2511-DNP	0	ea.	R3, R7, R11, R10, R14	RES, SMD, 0603, DNP-PLACE HOLDER, ROHS		
H2514-00R00-1/4W-T	1	ea.	R_IN	RES, SMD, 1210, 0Ω, 1/4W, TF, ROHS	VENKEL	CR1210-4W-000
H2514-DNP	0	ea.	R_OUT	RES, SMD, 1210, DNP, DNP, DNP, TF, ROHS		
GT11MSCBE-T	3	ea.	S1-S3	SWITCH-TOGGLE, SMD, 6PIN, SPDT, 2POS, ON-ON, ROHS	ITT INDUSTRIES/C&K DIVISION	GT11MSCBE
SJ-5003-BLACK	4	ea.	Bottom four corners	BUMPONS, 0.44inW x 0.20inH, DOMETOP, BLACK	3M	SJ-5003SPBL
5X8-STATIC-BAG	1	ea.	Place assy in bag	BAG, STATIC, 5X8, ZIP LOC	INTERSIL	212403-013
LABEL-RENAME BOARD	1	ea.	RENAME PCB TO: ISL8033EVAL1Z	LABEL, TO RENAME BOARD	INTERSIL	LABEL-RENAME BOARD
LABEL-SERIAL NUMBER	1	ea.		LABEL, FOR SERIAL NUMBER AND BOM REV #		

### ISL8033EVAL1Z, ISL8033AEVAL1Z Board Layout

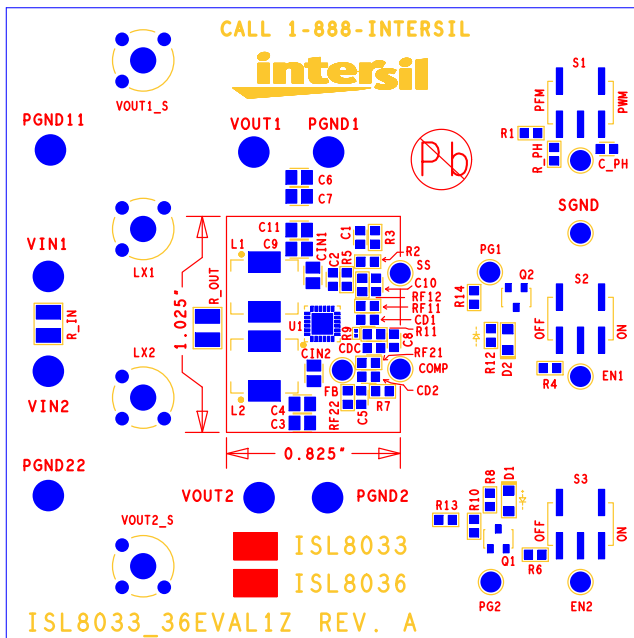

FIGURE 3. TOP COMPONENTS

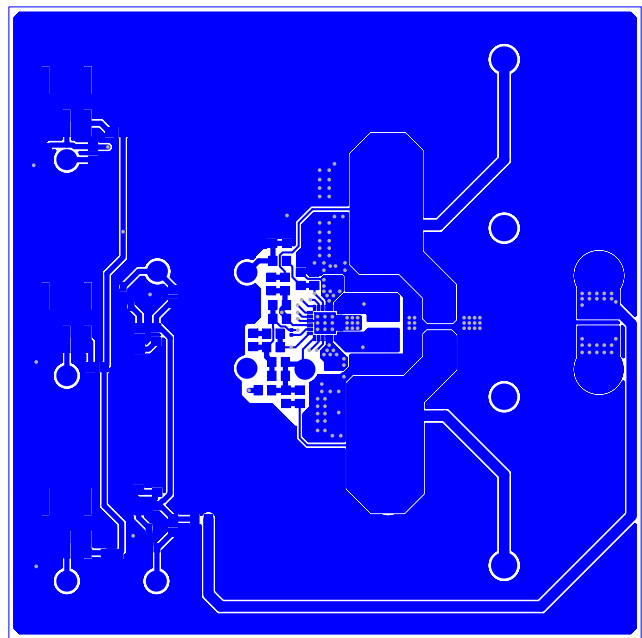

FIGURE 4. TOP LAYER ETCH

# ISL8033EVAL1Z, ISL8033AEVAL1Z Board Layout (Continued)

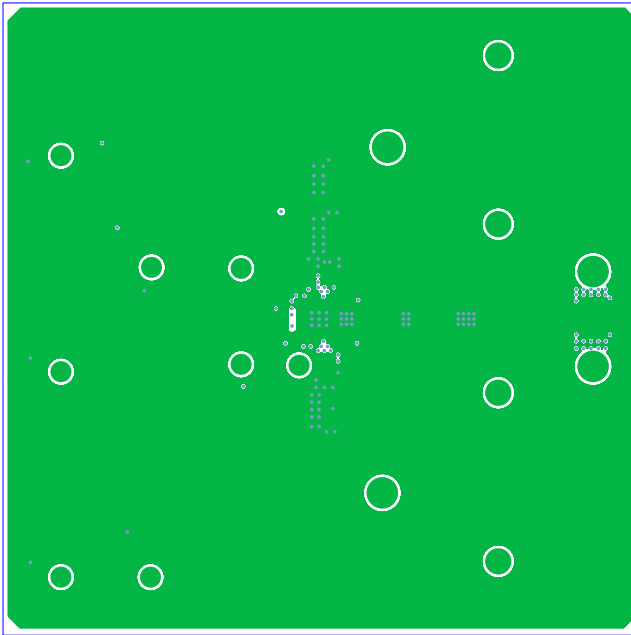

FIGURE 5. 2ND LAYER ETCH

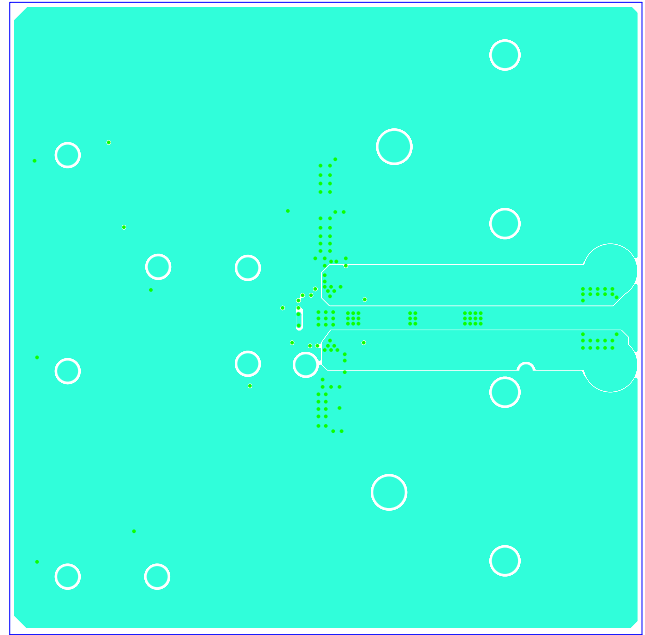

FIGURE 6. 3RD LAYER ETCH

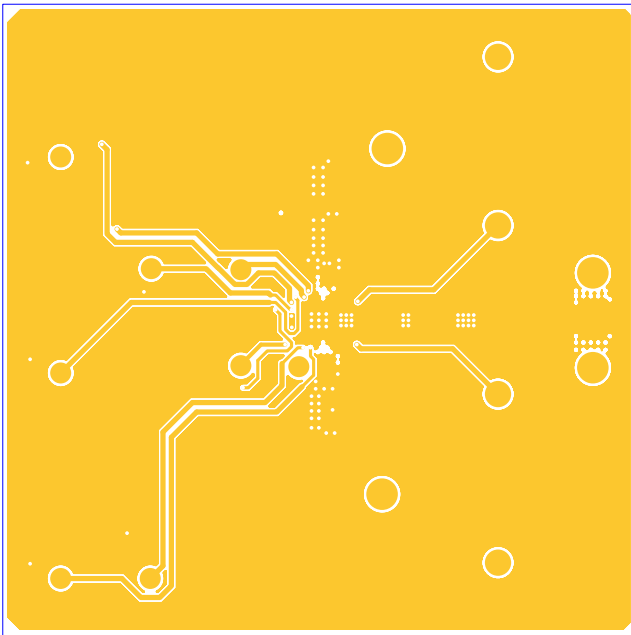

FIGURE 7. BOTTOM LAYER ETCH

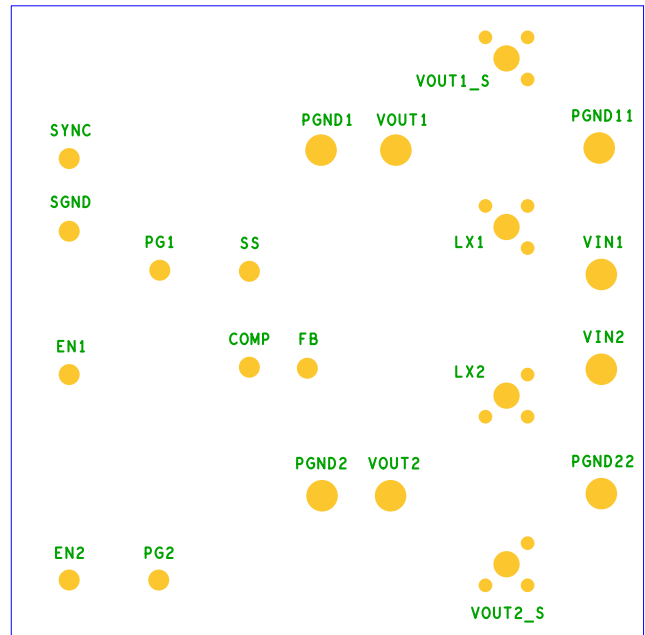

FIGURE 8. BOTTOM COMPONENTS (MIRROR)