

ISL8033DEMO1Z

Dual 3A Low Quiescent Current, High Efficiency, Synchronous Buck Regulator Demonstration Board

AN1611
Rev 1.00
Jul 6, 2016

Description

The ISL8033DEMO1Z kit is intended for use by individuals with requirements for Point-of-Load applications sourcing from 2.85V to 6V. The ISL8033DEMO1Z demonstration board is used to demonstrate the performance of the [ISL8033](#) low quiescent current mode converter.

The ISL8033 is offered in a 4mmx4mm 24 Ld QFN package with 1mm maximum height. The complete converter occupies less than 147.742mm².

Key Features

- Dual 3A high efficiency synchronous buck regulator with up to 95% efficiency
- Power-Goods (PG) output with 1.5ms delay
- 2.85V to 6V supply voltage
- 2% output accuracy over temperature/load/line
- Start-up with prebiased output
- External synchronization up to 6MHz
- Typical 8µA logic controlled shutdown current
- 100% maximum duty cycle for lowest dropout
- Internal current mode compensation
- Peak current limiting, hiccup mode short-circuit protection and over-temperature protection
- Negative current detection and protection
- Adjustable peak overload current

Recommended Equipment

The following materials are recommended to perform testing:

- 0V to 10V power supply with at least 3A source current capability or 5V battery
- Electronic loads capable of sinking current up to 3A
- Digital Multimeters (DMMs)
- 100MHz quad-trace oscilloscope
- Signal generator

Quick Setup Guide

1. Ensure that the circuit is correctly connected to the supply and loads prior to applying any power.
2. Connect the bias supply to VIN, the plus terminal to VIN and the negative return to P1.
3. Turn on the power supply.
4. Verify the output voltage is 1.8V for V_{OUT1} and 1.8V for V_{OUT2}.

Ordering Information

PART NUMBER	DESCRIPTION
ISL8033DEMO1Z	ISL8033 demonstration board

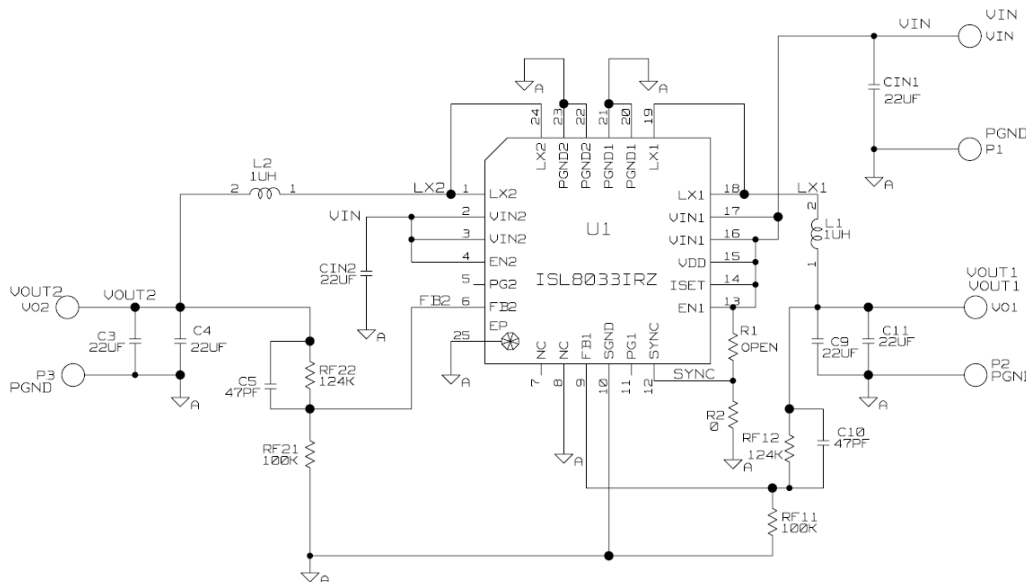

FIGURE 1. ISL8033DEMO1Z SCHEMATIC

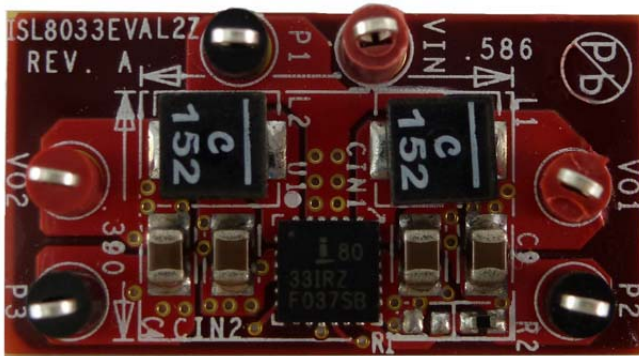

FIGURE 2. ISL8033DEMO1Z TOP OF BOARD (Note 1)



FIGURE 3. ISL8033DEMO1Z BOTTOM OF BOARD (Note 1)

NOTE:

1. ISL8033DEMO1Z is the new part number for the board formerly labeled ISL8033EVAL2Z. If your board is branded with ISL8033EVAL2Z, it is the ISL8033DEMO1Z demonstration board.

Bill of Materials

REFERENCE DESIGNATOR	DESCRIPTION	MFR	MFR PART
	PWB-PCB, ISL8033EVAL2Z, REVA, ROHS	LIANCHUANG	ISL8033EVAL2ZREVAPCB
C3, C4, C9, C11, CIN1, CIN2	CAP, SMD, 0805, 22 μ F, 6.3V, 20%, X5R, ROHS	TDK	C2012X5R0J226M
C5, C10	CAP, SMD, 0402, 47pF, 50V, 5%, NPO, ROHS	MURATA	GRM36COG470J050AQ
L1, L2	COIL-PWR INDUCTOR, SMD, 4mm 1.5 μ H, 20%, 4.1A, 14.4m Ω , ROHS	COILCRAFT (Note 2)	XFL4020-152MEC
		TDK (Note 2)	SPM4020T-1R5M-LR
U1	IC-DUAL 3A BUCK REGULATOR, 24P, QFN, 4X4, ROHS	INTERSIL	ISL8033IRZ
R2	RES, SMD, 0402, 0 Ω , 1/16W, 5%, TF, ROHS	VENKEL	CR0402-16W-00T
RF11, RF21	RES, SMD, 0402, 100k, 1/16W, 1%, TF, ROHS	PANASONIC	ERJ2RKF1003
RF12, RF22	RES, SMD, 0402, 124k, 1/16W, 1%, TF, ROHS	PANASONIC	ERJ-2RKF1243X
R1	RES, SMD, 0402, DNP, TF, ROHS		

NOTE:

2. Two manufacturers are provided as options for the inductor.

ISL8033DEMO1Z Board Layout (Note 3)

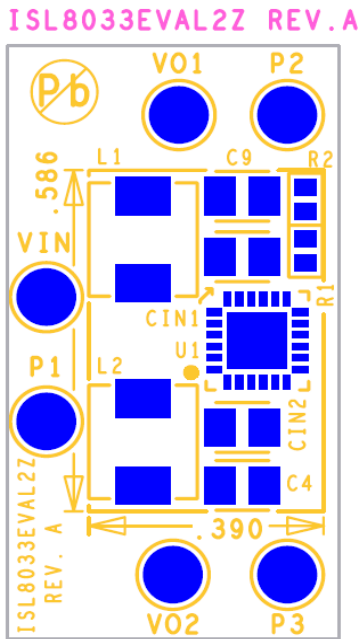

FIGURE 4. TOP COMPONENTS

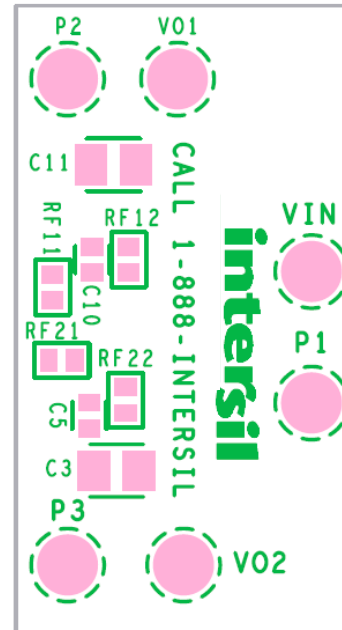

FIGURE 5. BOTTOM SILK SCREEN

NOTE:

- ISL8033DEMO1Z is the new part number for the board formerly labeled ISL8033EVAL2Z. If your board is branded with ISL8033EVAL2Z, it is the ISL8033DEMO1Z demonstration board.