

ISL8088EVAL1Z

REVA Dual 800mA Low Quiescent Current 2.25MHz High Efficiency Synchronous Buck Regulator

AN1492
Rev 2.00
February 14, 2014

Description

The ISL8088EVAL1Z kit is intended for use by individuals with requirements for Point-of-Load applications sourcing from 2.75V to 5.5V. The ISL8088EVAL1Z evaluation board is used to demonstrate the performance of the ISL8088 low quiescent current mode converter.

The ISL8088 is offered in a 3mmx3mm 10 Ld DFN package with 1mm maximum height. The complete converter occupies less than 1.8cm² area.

Key Features:

- Dual 800mA High Efficiency Synchronous Buck Regulator with up to 97% Efficiency
- 800mA Guaranteed Output Current per channel
- Power-Good (PG) output with 1ms Delay
- 2.75V to 5.5V Supply Voltage
- 3% Output Accuracy Over-Temperature/Load/Line
- Start-up with Pre-biased Output
- Internal Digital Soft-Start - 2ms
- Soft-Stop Output Discharge During Disabled
- 30µA Quiescent Supply Current in PFM Mode
- Selectable Forced PWM Mode and PFM Mode
- External Synchronization up to 4MHz
- Typical 6.5µA Logic Controlled Shutdown Current
- 100% Maximum Duty Cycle for Lowest Dropout
- Internal Current Mode Compensation
- Peak Current Limiting.
- Over-Temperature Protection
- Independent Enable

Recommended Equipment

The following materials are recommended to perform testing:

- 0V to 10V Power Supply with at least 3A source current capability or 5V battery
- Electronic Loads capable of sinking current up to 3A
- Digital Multimeters (DMMs)
- 100MHz quad-trace oscilloscope
- Signal generator

Quick Setup Guide

1. Ensure that the circuit is correctly connected to the supply and loads prior to applying any power.
2. Connect the bias supply to VIN. Plus terminal to VIN and negative return to PGND.
3. Verify that position is ON for SW2 and SW3.
4. Turn on the power supply.
5. Verify the output voltage is 2.5V for V_{OUT1} and 1.8V for V_{OUT2}.

Evaluating the Other Output Voltage

The ISL8088EVAL1Z kit output is preset to 2.5V for V_{OUT1} and 1.8V for V_{OUT2}; however, output voltages can be adjusted from 0.6V to 3.3V. The output voltage programming resistor, R2 (or R5 in Channel 2), will depend on the desired output voltage of the regulator. The value for the feedback resistor is typically between 0Ω and 750kΩ as shown in Equation 1.

Let's set R3 = 100kΩ, then R2 will be:

$$R2 = R3 \left(\frac{V_{OUT}}{V_{FB}} - 1 \right) \tag{EQ. 1}$$

If the output voltage desired is 0.6V, then R3 is left unpopulated and short R2. For faster response performance, add 10pF in parallel to R2.

Mode Control

The ISL8088 has a SYNC pin that controls the operation mode. SYNC pin connect to logic high or input voltage VIN for PFM mode; connect to logic low or ground for forced PWM mode. Connect to an external function generator for Synchronization. Negative edge trigger. Do not leave this pin floating.

TABLE 1. SWITCH SETTINGS

SW2&3	ENABLE	ON/OFF CONTROL
1	OFF	Disable V _{OUT}
3	ON	Enable V _{OUT}
SW1	SKIP	FUNCTION
1	PWM	Fixed PWM frequency at light load
3	PFM	Force continuous mode

ISL8088EVAL1ZREVA Schematic

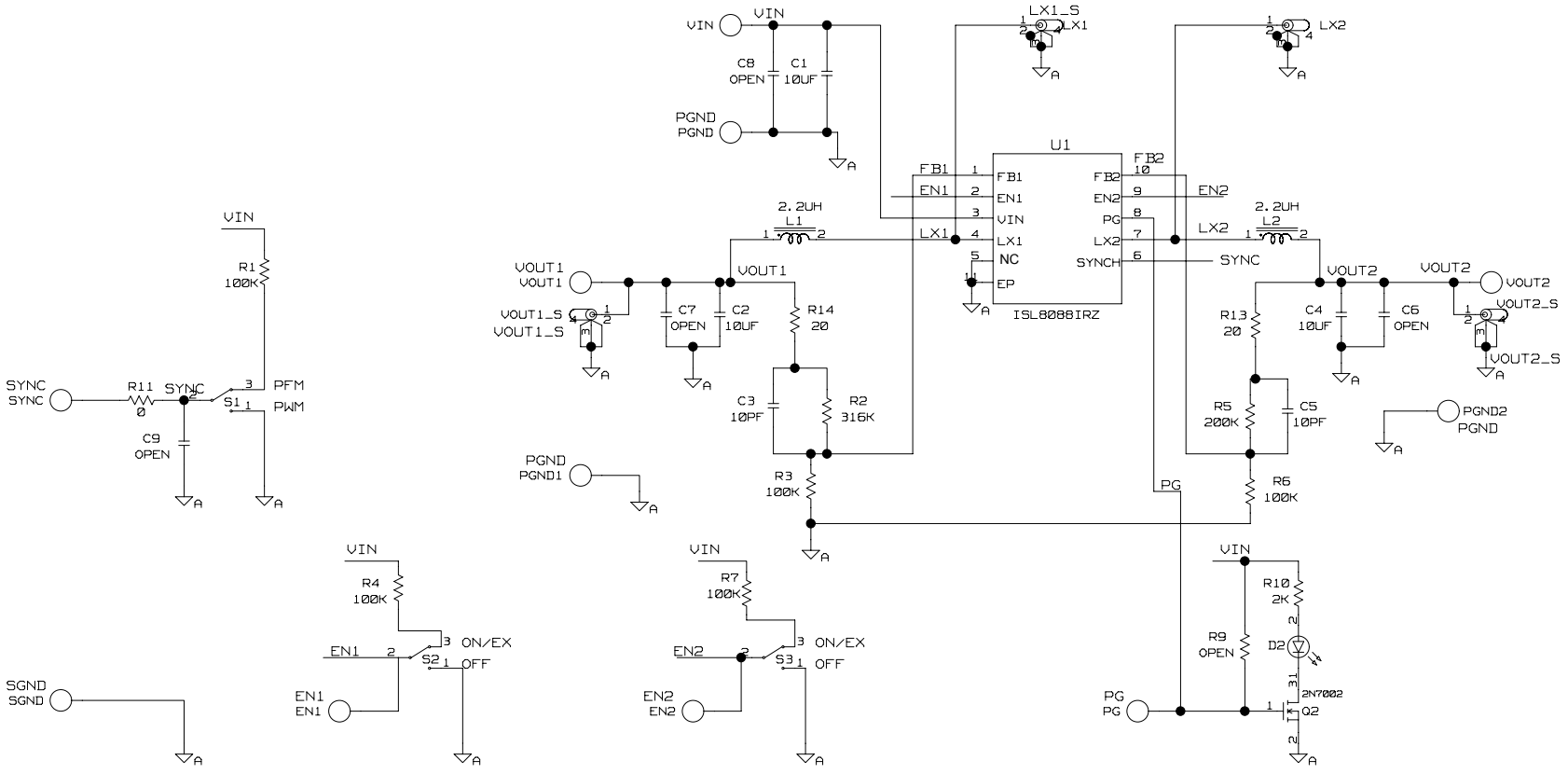

NOTE:
PLEASE KEEP FB1, FB2 PINS TRACES SHORT

TABLE 2. BILL OF MATERIALS

PART NUMBER	QTY	UNIT	REFERENCE DESIGNATOR	DESCRIPTION	MANUFACTURER	MANUFACTURER PART
ISL8088EVAL1ZREVAPCB	1	ea		PWB-PCB, ISL8088EVAL1Z, REVA, ROHS	TITAN	ISL8088EVAL1ZREVAPCB
H1045-00100-50V5-T	2	ea	C3, C5	CAP, SMD, 0603, 10pF, 50V, 5%, COG, ROHS	YAGEO	CC0603JRNPO9BN100
					VENKEL	C0603COG500-100JNE
					KEMET	C0603C100J5GACTU
					MURATA	GRM1885C1H100JA01D
					AVX	06035A100JAT2A
H1045-DNP	0	ea	C9	CAP, SMD, 0603, DNP- PLACE HOLDER, ROHS		
H1046-00106-6R3V10-T	3	ea	C1, C2, C4	CAP, SMD, 0805, 10μF, 6.3V, 10%, X5R, ROHS	VENKEL	C0805X5R6R3-106KNE
					KEMET	C0805C106K9PACTU
					AVX	08056D106KAT2A
					MURATA	GRM21BR60J106KE19L
					TAIYO YUDEN	JMK212BJ106KG
H1046-DNP	0	ea	C6 to C8	CAP, SMD, 0805, DNP- PLACE HOLDER, ROHS		
MDT2520-CR2R2M	2	ea	L1, L2	COIL-PWR INDUCTOR, SMD, 2520, 2.2μH, 20%, 1.35A, ROHS	TOKO	MDT2520-CR2R2M
1514-2	6	ea	PGND, PGND1, PGND2, VIN, VOUT1,VOUT2	CONN-TURRET, TERMINAL POST, TH, ROHS	KEYSTONE	1514-2
5000	4	ea	EN1, EN2, PG, SYNC	CONN-MINI TEST PT, VERTICAL, RED, ROHS	KEYSTONE	5000
5001	1	ea	SGND	CONN-MINI TEST PT, VERTICAL, BLK, ROHS	KEYSTONE	5001
LTST-C170CKT	1	ea	D2	LED-GaAs RED, SMD, 2mmx1.25mm, 100mW, 40mA, 10mcd, ROHS	LITEON/VISHAY	LTST-C170CKT
					ROHM	SML-210LTT86
					STANLEY ELEC.	BR112H-TR
ISL8088IRZ	1	ea	U1	IC-DUAL SYNC. BUCK REGULATOR, 10P, DFN, 3X3, ROHS	INTERSIL	ISL8088IRZ
2N7002-T	1	ea	Q2	TRANSISTOR, N-CHANNEL, 3LD, SOT-23, 60V, 115mA	NAT'L SEMICNDTR	2N7002
					MOTOROLA	2N7002LT1
H2511-00200-1/10W1-T	2	ea	R13, R14	RES, SMD, 0603, 20Ω, 1/10W, 1%, TF, ROHS	PANASONIC	ERJ-3EKF20R0V
					YAGEO	RC0603FR-0720RL
					VENKEL	CR0603-10W-20R0FT
H2511-00R00-1/10W-T	1	ea	R11	RESISTOR, SMD, 0603, 0Ω, 1/10W, TF, ROHS		
H2511-01003-1/10W1-T	5	ea	R1, R3, R4, R6, R7	RES, SMD, 0603, 100k, 1/10W, 1%, TF, ROHS		
H2511-02001-1/10W1-T	1	ea	R10	RES, SMD, 0603, 2k, 1/10W, 1%, TF, ROHS	KOA	RK73H1JT2D2001F
					VENKEL	CR0603-10W-2001FT

TABLE 2. BILL OF MATERIALS (Continued)

PART NUMBER	QTY	UNIT	REFERENCE DESIGNATOR	DESCRIPTION	MANUFACTURER	MANUFACTURER PART
H2511-02003-1/10W1-T	1	ea	R5	RES, SMD, 0603, 200k, 1/10W, 1%, TF, ROHS	VENKEL	CR0603-10W-2003FT
					YAGEO	RC0603FR-07200KL
					VISHAY/DALE	CRCW0603200KFKEA
					PANASONIC	ERJ-3EKF2003V
					ROHM	MCR03EZPF2003
H2511-03163-1/10W1-T	1	ea	R2	RES, SMD, 0603, 316k, 1/10W, 1%, TF, ROHS	PANASONIC	ERJ-3EKF3163V
					VENKEL	CR0603-10W-3163FT
					ROHM	MCR03EZPF3163
					YAGEO	RC0603FR-07316KL
					VISHAY/DALE	CRCW0603316KFKEA
H2511-DNP	0	ea	R9	RES, SMD, 0603, DNP-PLACE HOLDER, ROHS		
GT11MSCBE-T	3	ea	S1 to S3	SWITCH-TOGGLE, SMD, ULTRAMINI, 1P, SPST MINI	C&K COMPONENTS	GT11MSCKE

ISL8088EVAL1Z Board Layout

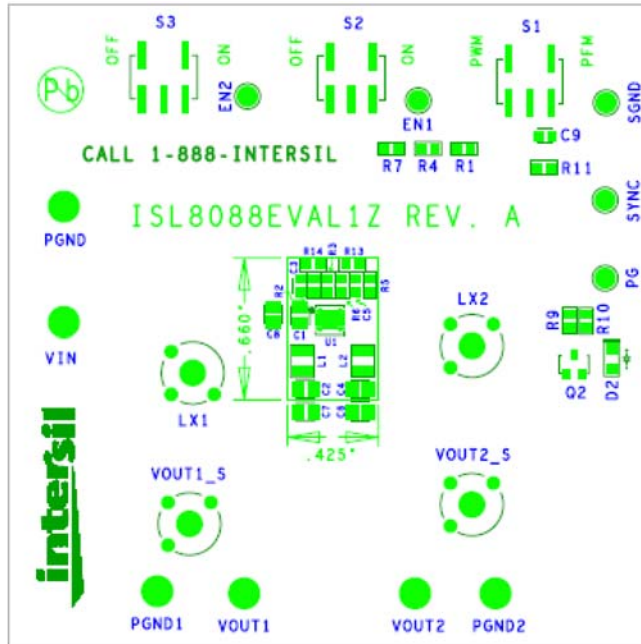

FIGURE 1. TOP COMPONENTS

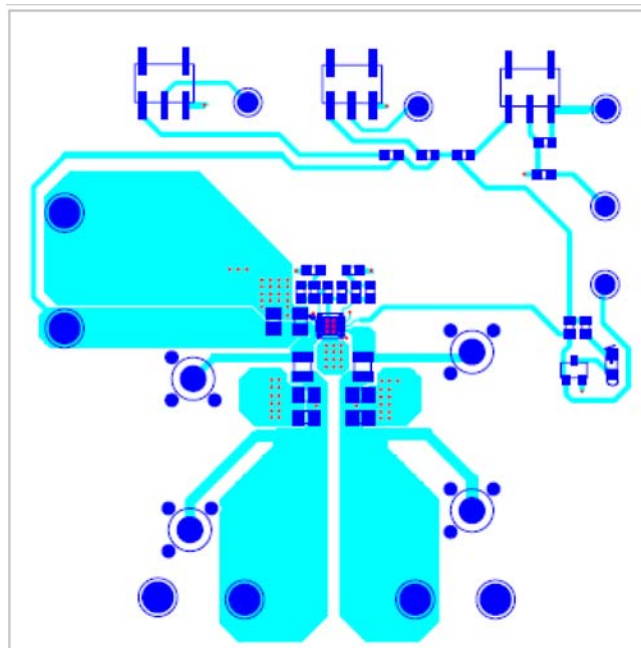

FIGURE 2. TOP LAYER ETCH

ISL8088EVAL1Z Board Layout (Continued)

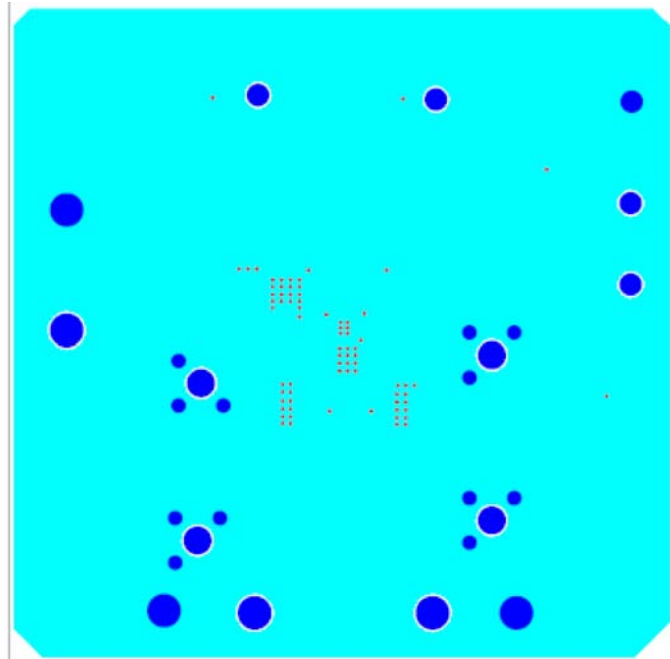

FIGURE 3. 2ND LAYER ETCH

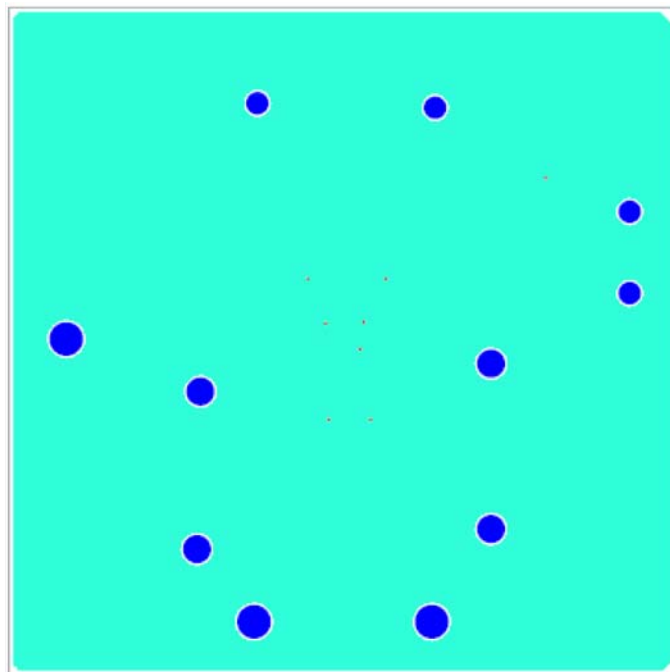

FIGURE 4. 3RD LAYER ETCH

ISL8088EVAL1Z Board Layout (Continued)

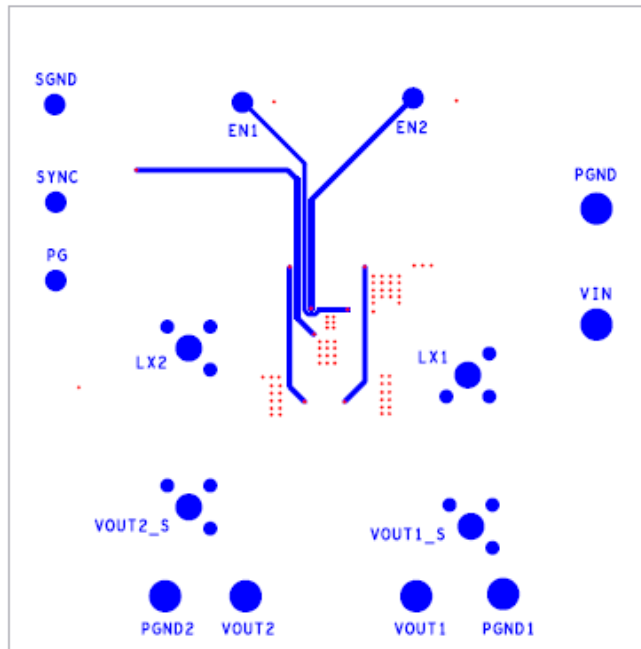

FIGURE 5. BOTTOM LAYER COMPONENTS (MIRRORS)