

## ISL8088EVAL2Z

Evaluation Board User Guide, Dual 800mA Low Quiescent Current High Efficiency Synchronous Buck Regulator-Small Form Factor

AN1600  
Rev 2.00  
Jul 15, 2016

### Description

The ISL8088EVAL2Z is intended for use by individuals with requirements for Point-of-Load applications sourcing from 2.75V to 5.5V. The ISL8088EVAL2Z board is used to demonstrate the performance of the [ISL8088](#) low quiescent current mode converter.

The ISL8088 is offered in a 3mmx3mm 10 Ld DFN package with 1mm maximum height. The complete converter occupies less than 77.419mm<sup>2</sup> area.

### Recommended Equipment

The following materials are recommended to perform testing:

- 0V to 10V power supply with at least 3A source current capability or 5V battery
- Electronic loads capable of sinking current up to 3A
- Digital Multimeters (DMMs)
- 100MHz quad-trace oscilloscope
- Signal generator

### Quick Setup Guide

1. Ensure that the circuit is correctly connected to the supply and loads prior to applying any power.
2. Connect the bias supply to VIN, plus terminal to VIN and negative return to P1.
3. Turn on the power supply.
4. Verify the output voltage is 2.5V for V<sub>OUT1</sub> and 1.8V for V<sub>OUT2</sub>.

### Key Features

- Dual 800mA high efficiency synchronous buck regulator with up to 97% efficiency
- 800mA guaranteed output current per channel
- Power-Goods (PG) output with 1ms delay
- 2.75V to 5.5V supply voltage
- 3% output accuracy over temperature/load/line
- Start-up with prebiased output
- Internal digital soft-start - 2ms
- Soft-stop output discharge while disabled
- 30µA quiescent supply current in PFM mode
- Selectable forced PWM mode and PFM mode
- External synchronization up to 4MHz
- Typical 6.5µA logic controlled shutdown current
- 100% maximum duty cycle for lowest dropout
- Internal current mode compensation
- Peak current limiting
- Over temperature protection
- Independent enable

### Ordering Information

PART NUMBER	DESCRIPTION
ISL8088EVAL2Z	ISL8088 small form factor evaluation board

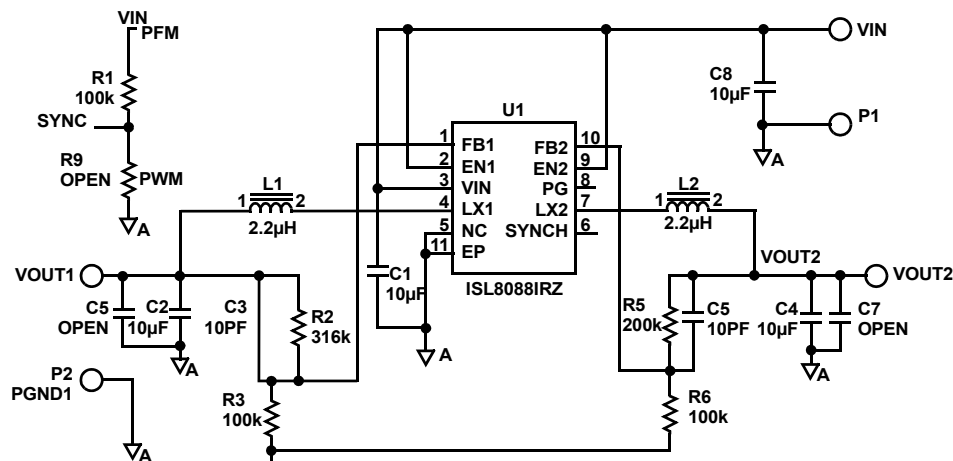

Note: Please keep FB1, FB2 pins traces short

FIGURE 1. ISL8088EVAL2Z SCHEMATIC

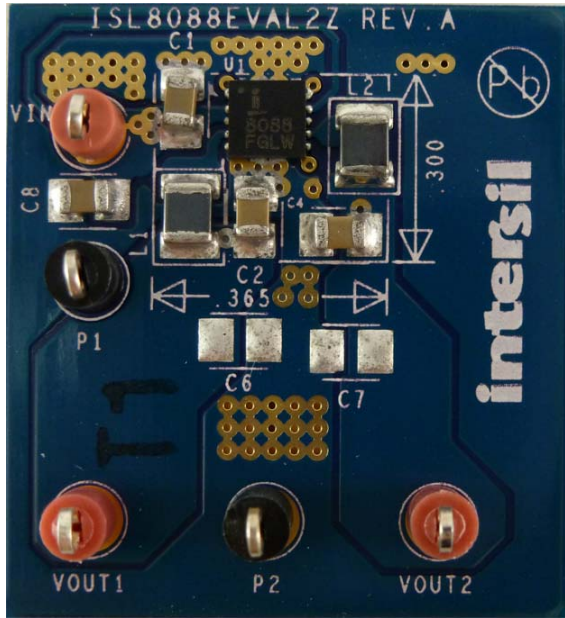

FIGURE 2. ISL8088EVAL2Z TOP SIDE



FIGURE 3. ISL8088EVAL2Z BOTTOM SIDE

## ISL8088EVAL2Z Bill of Materials

QTY	UNIT	REFERENCE DESIGNATOR	DESCRIPTION	MANUFACTURER	MANUFACTURER PART
1	ea.		PWB-PCB, ISL8088EVAL2Z, REVA, ROHS	IMAGINEERING INC	ISL8088EVAL2ZREVAPCB
4	ea.	C1, C2, C4, C8	CAPACITOR, SMD, 0805, 10µF, 6.3V, 10%, X5R	MURATA	GRM21BR60J106KE01L
0	ea.	C6, C7	CAP,SMD, 0805, DNP-PLACE HOLDER, ROHS		
2	ea.	C3, C5	CAP-RF HIQ, SMD, 0402, 10pF, 50V, 5%, COG, ROHS	JOHANSON TECHNOLOGY	500R07S100JV4T
2	ea.	L1, L2	COIL-PWR INDUCTOR, SMD, 2520, 2.2µH, 20%, 1.35A, ROHS	TOKO ( <a href="#">Note 1</a> )	MDT2520-CR2R2M
	ea.			TDK ( <a href="#">Note 1</a> )	MLP2520H2R2ST0S1
3	ea.	VIN, VOUT1, VOUT2	CONN-MINI TEST PT, VERTICAL, RED, ROHS	KEYSTONE	5000
2	ea.	P1, P2	CONN-MINI TEST PT, VERTICAL, BLK, ROHS	KEYSTONE	5001
1	ea.	U1	IC-DUAL SYNC. BUCK REGULATOR, 10P, DFN, 3X3, ROHS	INTERSIL	ISL8088IRZ
3	ea.	R1, R3, R6	RES, SMD, 0402, 100k, 1/16W, 1%, TF, ROHS	PANASONIC	ERJ2RKF1003
1	ea.	R5	RES, SMD, 0402, 200k, 1/16W, 1%, TF, ROHS	ROHM	MCR01MZPF2003
1	ea.	R2	RES, SMD, 0402, 316k, 1/16W, 1%, TF, ROHS	PANASONIC	ERJ-2RKF3163X
0	ea.	R9	RES, SMD, 0402, DNP, DNP, DNP, TF, ROHS		

NOTE:

- Two manufacturers are provided as options for the inductor.

# ISL8088EVAL2Z Board Layout

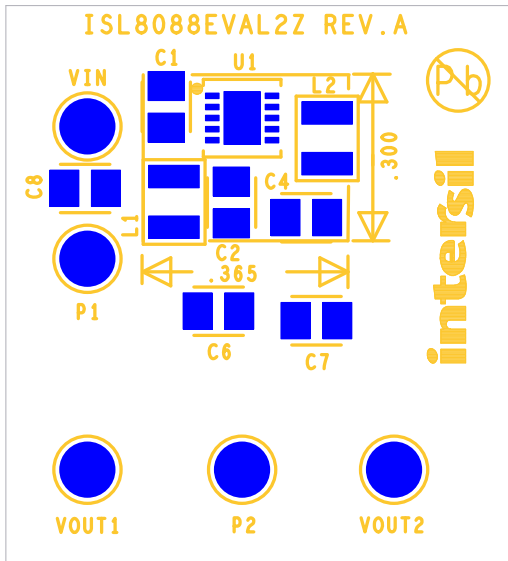

FIGURE 4. TOP COMPONENTS

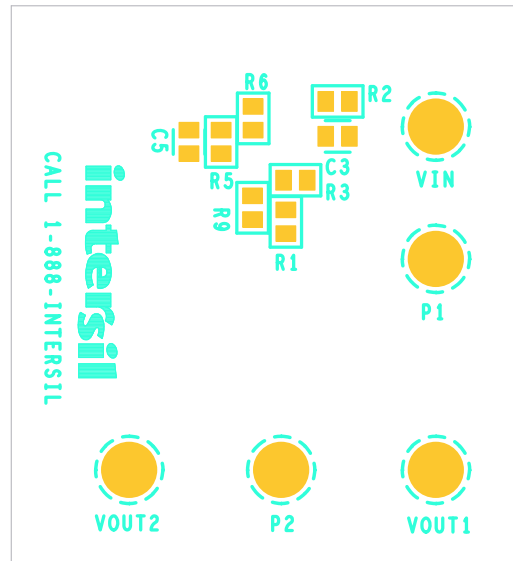

FIGURE 5. BOTTOM SILK SCREEN