

ISL8105AEVAL1Z

Evaluation Board

AN1258
Rev 0.00
Nov 1, 2007

Description

The ISL8105AEVAL1Z evaluation board highlights the operations of the ISL8105A controller in a DC/DC application. The evaluation board is configured for an output voltage of 1.8V and 15A maximum load.



FIGURE 1. ISL8105AEVAL1Z EVALUATION BOARD

Power and Load Connections

INPUT VOLTAGE

The evaluation board is optimized for an input supply of 12V, however, the input supply based on the connection can range from 4.5V to 5.5V or 6.5V to 14.4V.

The IC bias supply and the converter input voltage are connected together through R₁₀ to provide single rail power supply application.

OUTPUT VOLTAGE LOADING AND MONITORING

Connect the positive lead of the electronic load and the positive lead of a digital multimeter to the V_{OUT} terminal (J4) and the ground lead to the GND terminal (J5). The scope probe terminal (TPV01) can be used to monitor V_{OUT} with an oscilloscope.

Start-up

The ISL8105A starts up when V_{BIAS} rises above POR threshold and the COMP/EN rises above V_{DISABLE} level. The entire start-up time sequence from POR typically takes up to 17ms. There is fixed 6.8ms delay for the POR to initiate the Overcurrent Protection (OCP) sample and hold operation. The OCP sample and hold operation takes an additional 0ms to 3.4ms (the longer time occurs with the higher overcurrent setting). When the OCP sampling and hold operations are done, the soft-start function internally ramps the reference on the non-inverting terminal of the error amp from 0V to 0.6V in 6.8ms (typ).

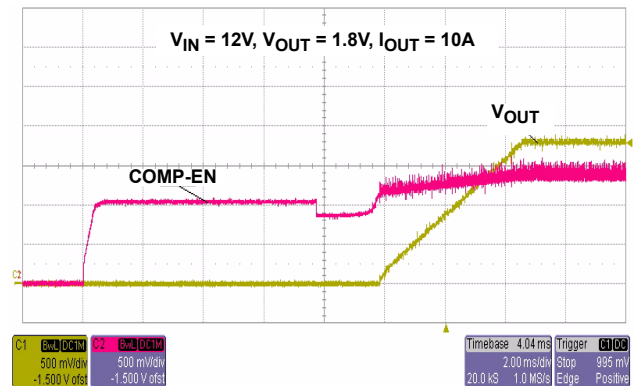

FIGURE 2. SOFT-START

Figure 1 shows the start-up profile of the ISL8105AEVAL1Z in relation to the start-up of the 12V input supply and the bias supply.

Soft-Start with Pre-Biased Output

If the output is pre-biased to a voltage less than the expected value, the ISL8105A will detect that condition. Neither MOSFET will turn on until the soft-start ramp voltage exceeds the output; V_{OUT} starts seamlessly ramping from there.

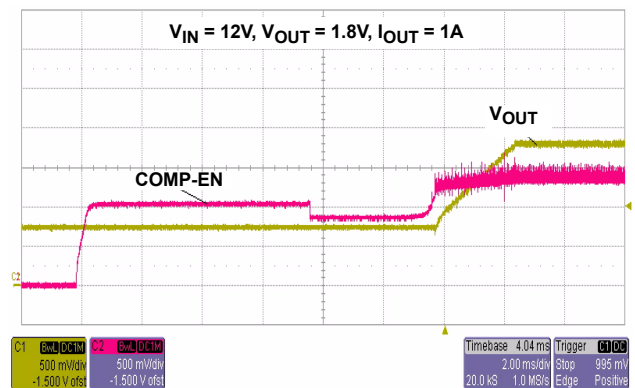

FIGURE 3. SOFT-START WITH PRE-BIASED OUTPUT

Output Performance

Switching Frequency

The evaluation board comes with a ISL8105A that has a fixed switching frequency of 600kHz.

Output Ripple

Figure 4 shows the ripple voltage on the output of the regulator.

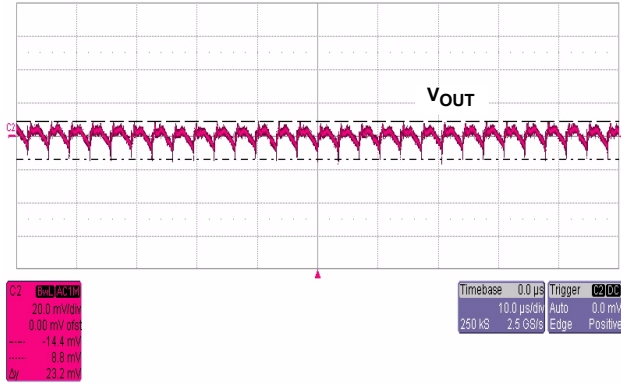

FIGURE 4. OUTPUT VOLTAGE RIPPLE (20MHz BW)

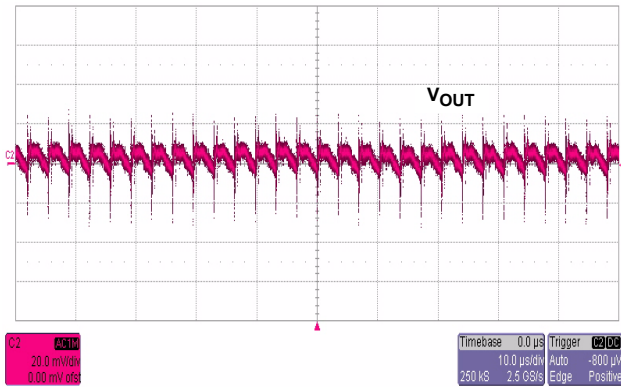

FIGURE 5. OUTPUT VOLTAGE RIPPLE AND NOISE (500MHz BW)

Transient Performance

Figures 6, 7 and 8 show the response of the output when subjected to transient loading from 7.5A to 15A.

Overcurrent Protection

The overcurrent function limits the output current by using the bottom-side MOSFET's $r_{DS(ON)}$ to monitor the current. A resistor, R_{BSOC} , (R_g) programs the overcurrent trip level. This method enhances the converter's efficiency and reduces cost by eliminating a current sensing resistor. If overcurrent is detected, the output immediately shuts off, it cycles the soft-start function in a hiccup mode (2 dummy soft-start time-outs, then up to one real one) to provide fault protection. If the shorted condition is not removed, this cycle will continue indefinitely. Figure 9 shows the overcurrent response and hiccup mode operation.

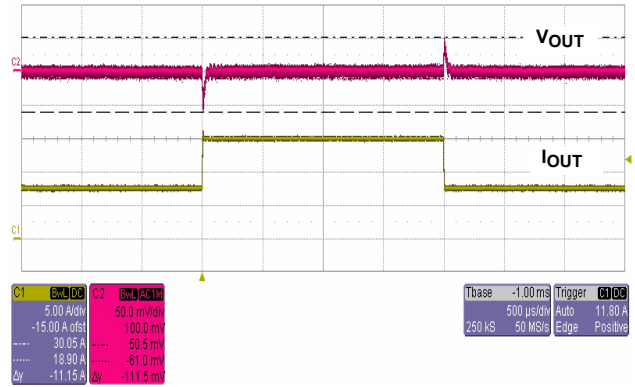

FIGURE 6. TRANSIENT RESPONSE

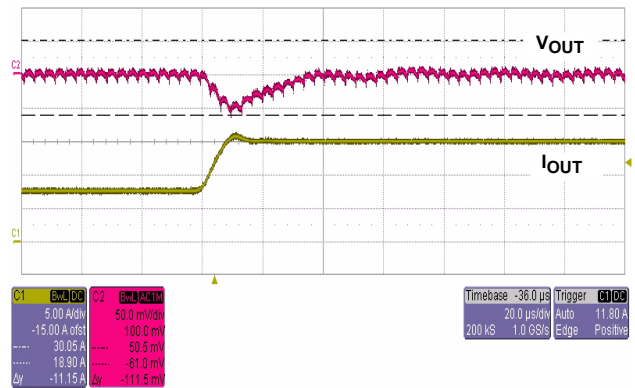

FIGURE 7. TRANSIENT RESPONSE

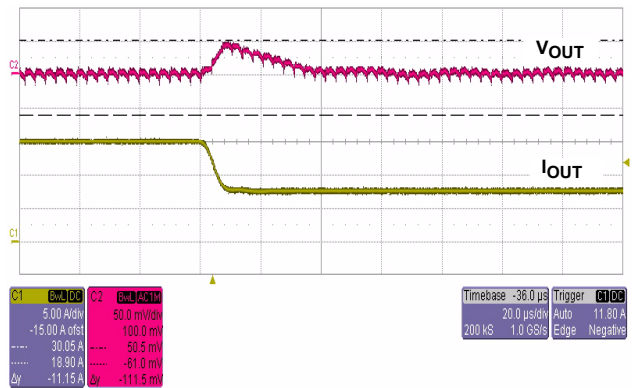

FIGURE 8. TRANSIENT RESPONSE

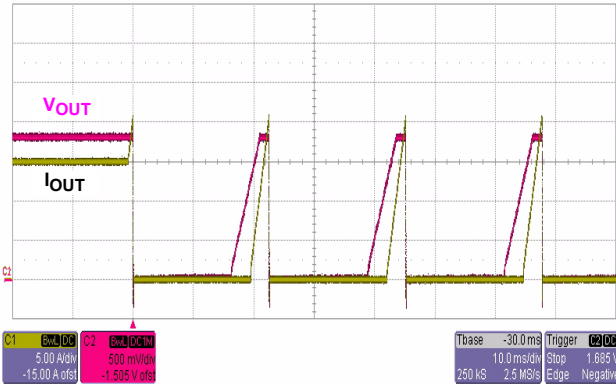

FIGURE 9. OVERCURRENT HICCUP MODE

The overcurrent function will trip at a peak inductor current (I_{PEAK}) determined by Equation 1:

$$I_{PEAK} = \frac{2 \cdot I_{OCSET} \cdot R_{OCSET}}{r_{DS(ON)}} \quad (EQ. 1)$$

where I_{OCSET} is the internal 21.5µA OCSET current source.

The OC trip point varies mainly due to the MOSFET’s $r_{DS(ON)}$ variations. To avoid overcurrent tripping in the normal operating load range, calculate the R_{OCSET} resistor from Equation 1 using:

1. The maximum $r_{DS(ON)}$ at the highest junction temperature.
2. The minimum I_{OCSET} from the specification table.

Determine I_{PEAK} for $I_{PEAK} > I_{OUT(MAX)} + (\Delta I)/2$

where ΔI is the output inductor ripple current.

The overcurrent trip point on the evaluation board has been set to 19A for 5V_{BIAS} (24A for 12V_{BIAS}).

Figure 10 shows the output voltage recovers from overcurrent condition.

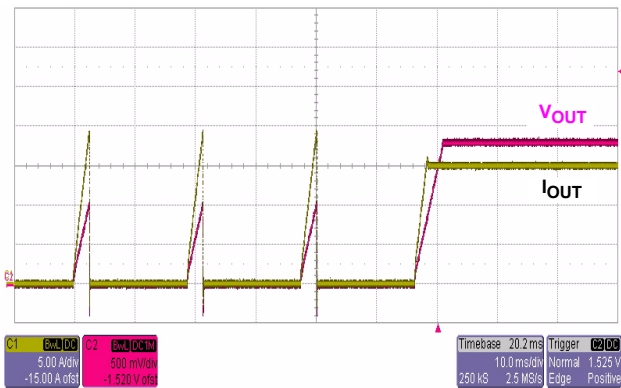

FIGURE 10. OVERCURRENT HICCUP MODE

Efficiency

ISL8105A based regulators enable the design of highly efficient systems. The efficiency of the evaluation board using a 5V and a 12V input supply is shown in Figure 11.

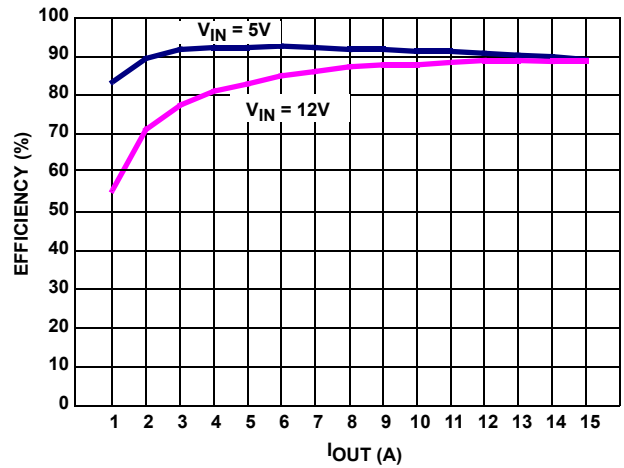

FIGURE 11. EVALUATION BOARD EFFICIENCY (V_{OUT} = 1.8V)

References

For Intersil documents available on the web, see <http://www.intersil.com/>

- [1] ISL8105, ISL8105A Data Sheet, Intersil Corporation, FN6306

ISL8105AEVAL1Z Schematic

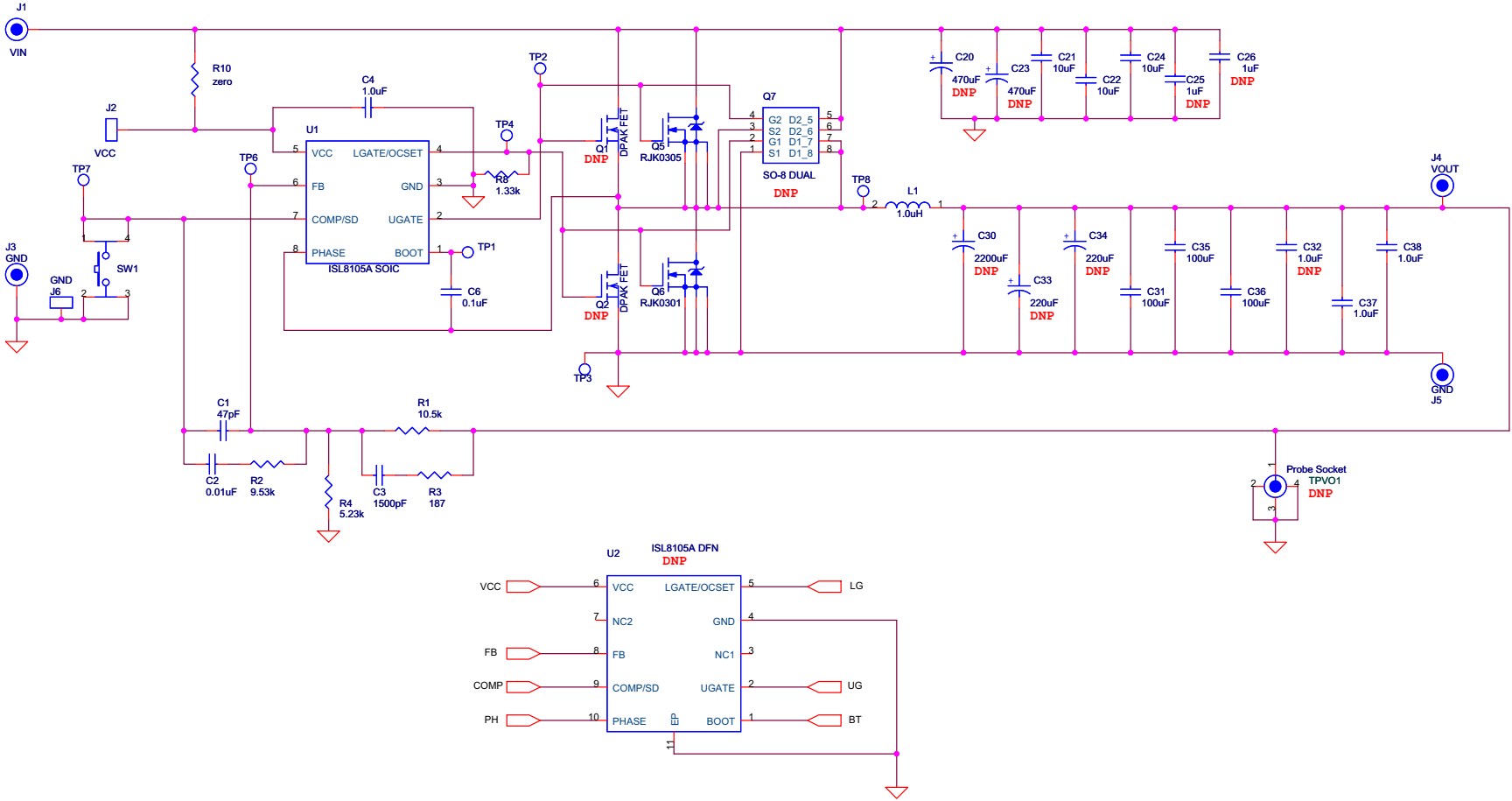

ISL8105AEVAL1Z Bill of Materials

ID	REFERENCE	QTY	PART NUMBER	PART TYPE	DESCRIPTION	PACKAGE	VENDOR
1	U1	1	ISL8105AIBZ	IC, Linear	IC, Single PWM Controller	8LD SOIC	Intersil
2	U2	DNP	ISL8105AIRZ	IC, Linear	IC, Single PWM Controller	10LD DFN	Intersil
3	Q1, Q2	DNP		MOSFET	N-Channel	DPAK	
4	Q5	1	RJK0305	MOSFET	N-Channel, 30V	LFPAK	Renasas
5	Q6	1	RJK0301	MOSFET	N-Channel, 30V	LFPAK	Renasas
6	Q7	DNP		MOSFET	N-Channel, Dual	8LD SOIC	
7	L1	1	IHLP-5050FDER1R0M01	Inductor	1.0μH, high current inductor	SMD	Vishay
8	SW1	1	EVQ-PAD04M	Push Switch	SWITCH-PUSH, TH, 6mm, 1P, PUSHB MOM-SPST		PANASONIC
CAPACITORS							
9	C1	1		Capacitor, Ceramic, X7R	47pF, 50V, 5%, NPO, ROHS	SM_0603	TDK/Generic
10	C2	1		Capacitor, Ceramic, X7R	0.01μF, 50V, 10%, ROHS	SM_0603	TDK/Generic
11	C3	1		Capacitor, Ceramic, X7R	1500pF, 50V, 10%, ROHS	SM_0603	TDK/Generic
12	C4	1		Capacitor, Ceramic, X7R	1μF, 16V, 10%, X7R, ROHS	SM_0603	TDK/Generic
13	C6	1		Capacitor, Ceramic, X7R	0.1μF, 16V, 10%, ROHS	SM_0603	TDK/Generic
14	C20, C23	DNP	16MCZ470M8X11.5	Capacitor, Alum. Elec	470μF, 16V, 20%, 21mΩ, Pb-free	RADIAL 8x11	RUBYCON
15	C21, C22, C24	3		Capacitor, Ceramic, X5R	10μF, 16V, 10%, ROHS	SM_1210	TDK/Generic
16	C25, C26	DNP		Capacitor, Ceramic, X5R	1μF, 6.3V, 20%, ROHS	SM_1812	TDK/Generic
17	C30, C33, C34	DNP	6.3MCZ1200M8X16	Capacitor, Alum. Elec	1200μF, 6.3V, 20%, 18mΩ, Pb-free	RADIAL 8x16	RUBYCON
18	C31, C35, C36	3		Capacitor, Ceramic, X5R	100μF, 6.3V, 20%, ROHS	SM_1812	TDK/Generic
19	C32	DNP		Capacitor, Ceramic, X5R	1μF, 6.3V, 10%, ROHS	SM_0603	TDK/Generic
20	C37, C38	2		Capacitor, Ceramic, X5R	1μF, 6.3V, 10%, ROHS	SM_0603	TDK/Generic
RESISTORS							
21	R1	1		Resistor, Film	10.5kΩ, 1%, 1/16W	SM_0603	Panasonic/Generic
22	R2	1		Resistor, Film	9.53kΩ, 1%, 1/16W	SM_0603	Panasonic/Generic
23	R3	1		Resistor, Film	187Ω, 1%, 1/16W	SM_0603	Panasonic/Generic
24	R4	1		Resistor, Film	5.23kΩ, 1%, 1/16W	SM_0603	Panasonic/Generic
25	R8	1		Resistor, Film	1.33kΩ, 1%, 1/16W	SM_0603	Panasonic/Generic
26	R10	1	RC0805JR-070RL	Resistor, Film	1/8W, TF, ROHS	SM_0805	YAGEO
OTHERS							
27	TPVO1	DNP	0293-0-15-15-16-27-10-0	Terminal, Scope Probe	CONN-PIN RECEPTACLE, 0.086 DIA, 0.200 L, ROHS		MILL-MAX
28	J1, J3, J4, J5	4	111-0702-001	Banana Connector	CONN-GEN, BIND. POST, THMBNUT-GND		JOHNSON COMPONENTS
29	J2, J6	2	1514-2	Turret Post	CONN-TURRET, TERMINAL POST, TH, ROHS		Keystone
30	TP1-TP4, TP6-TP8	DNP	5002	Test Point	CONN-MINI TEST POINT, VERTICAL, WHITE, ROHS		Keystone

ISL8105AEVAL1Z Printed Circuit Board Layers

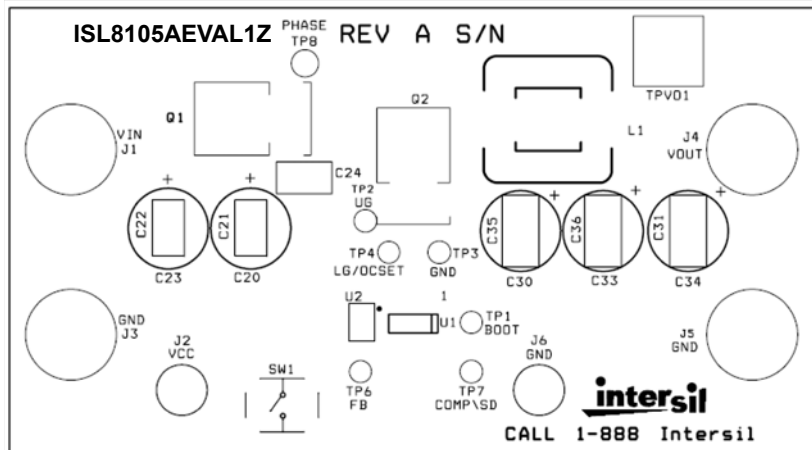

FIGURE 12. ISL8105AEVAL1Z - TOP LAYER (SILKSCREEN)

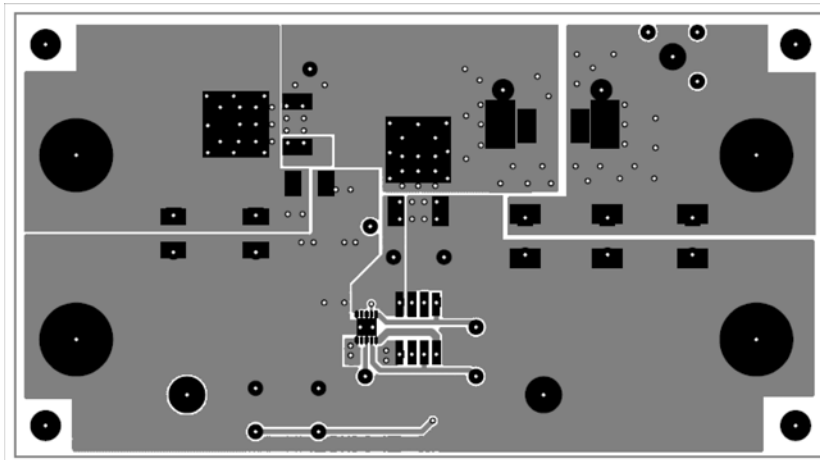

FIGURE 13. ISL8105AEVAL1Z - TOP LAYER (COMPONENT SIDE)

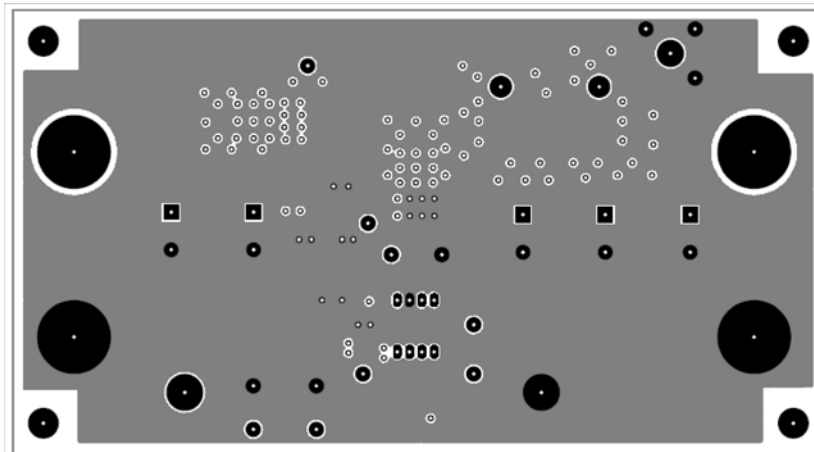

FIGURE 14. ISL8105AEVAL1Z - LAYER 2

ISL8105AEVAL1Z Printed Circuit Board Layers (Continued)

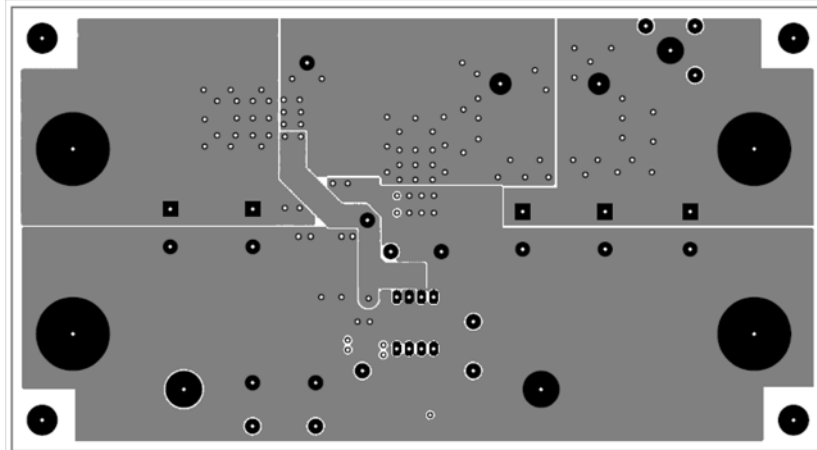

FIGURE 15. ISL8105AEVAL1Z - LAYER 3

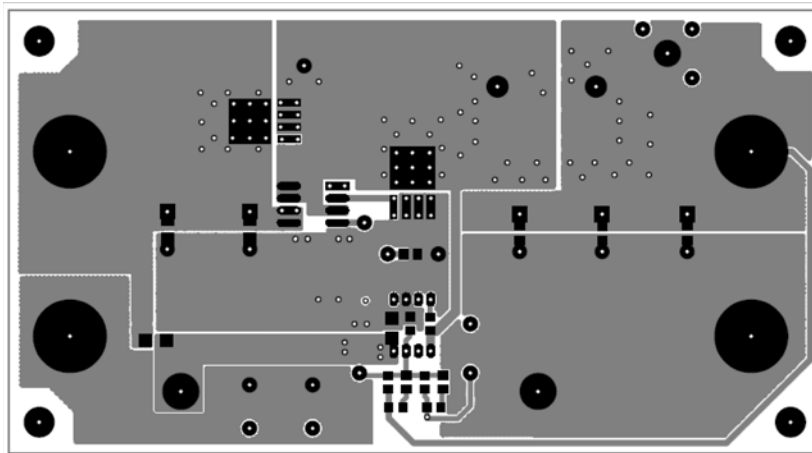

FIGURE 16. ISL8105AEVAL1Z - LAYER 4

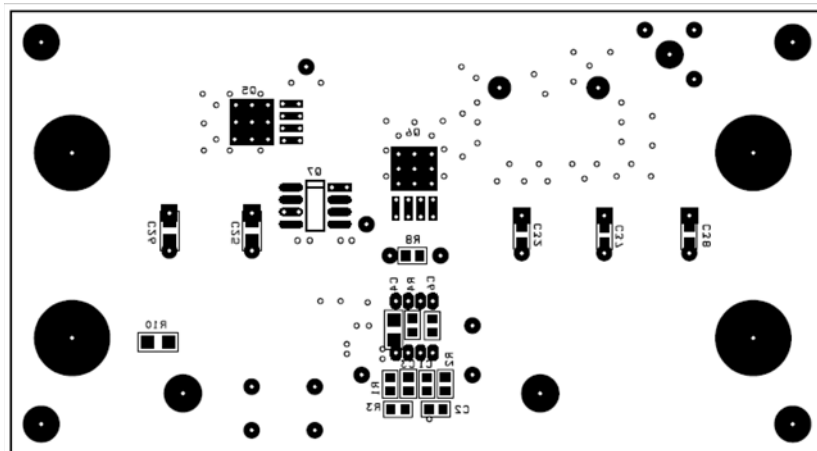

FIGURE 17. ISL8105AEVAL1Z - BOTTOM LAYER (SOLDER SIDE)