

ISL8117DEMO1Z

Demonstration Board User Guide

UG031
Rev 0.00
May 22, 2015

Description

The ISL8117DEMO1Z demonstration board (shown in [Figure 1](#)) features the [ISL8117](#). The ISL8117 is a 60V high voltage synchronous buck controller that offers external soft-start, independent enable functions and integrates UV/OV/OC/OT protection. Its current mode control architecture and internal compensation network keep peripheral component count minimal. Programmable switching frequency ranging from 100kHz to 2MHz helps to optimize inductor size while the strong gate driver delivers up to 30A for the buck output.

Specifications

The ISL8117DEMO1Z demonstration board is designed for high current applications. The current rating of the ISL8117DEMO1Z is limited by the FETs and inductor selected. The electrical ratings of ISL8117DEMO1Z are shown in [Table 1](#).

TABLE 1. ELECTRICAL RATINGS

PARAMETER	RATING
Input Voltage	4.5V to 60V
Switching Frequency	600kHz
Output Voltage	3.3V
Output Current	6A
OCP Set Point	Minimum 8A at ambient room temperature

Key Features

- Small, compact design
- Wide input range: 4.5V to 60V
- High light-load efficiency in pulse skipping DEM operation
- Programmable soft-start
- Optional DEM/CCM operation
- Supports prebias output with SR soft-start
- External frequency sync
- PGOOD indicator
- OCP, OVP, OTP, UVP protection

References

- [ISL8117](#) datasheet

Ordering Information

PART NUMBER	DESCRIPTION
ISL8117DEMO1Z	High Voltage PWM Step-Down Synchronous Buck Controller

Recommended Testing Equipment

The following materials are recommended to perform testing:

- 0V to 60V power supply with at least 10A source current capability
- Electronic loads capable of sinking current up to 10A
- Digital Multimeters (DMMs)
- 100MHz quad-trace oscilloscope

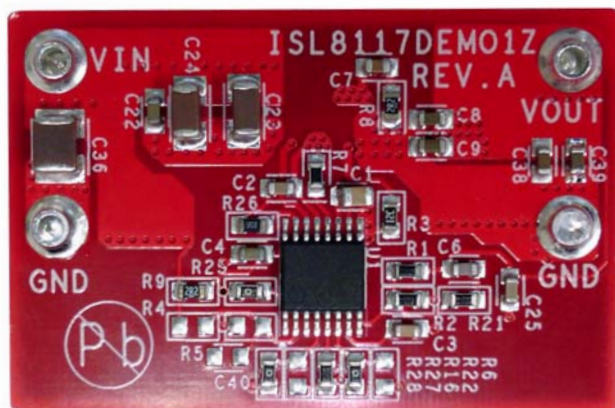

FIGURE 1. ISL8117DEMO1Z DEMONSTRATION BOARD TOP



FIGURE 2. ISL8117DEMO1Z DEMONSTRATION BOARD BOTTOM

Quick Test Guide

1. Ensure that the circuit is correctly connected to the supply and electronic loads prior to applying any power. Please refer to [Figure 4](#) for proper setup.
2. Turn on the power supply.
3. Adjust input voltage V_{IN} within the specified range and observe output voltage. The output voltage variation should be within 3%.
4. Adjust load current within the specified range and observe output voltage. The output voltage variation should be within 3%.
5. Use an oscilloscope to observe output voltage ripple and phase node ringing. For accurate measurement, please refer to [Figure 3](#) for proper test setup.

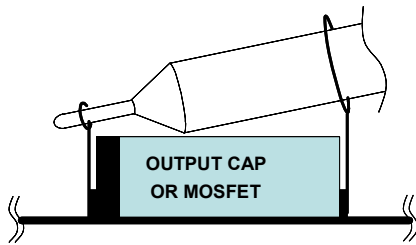

FIGURE 3. PROPER PROBE SETUP TO MEASURE OUTPUT RIPPLE AND PHASE NODE RINGING

Functional Description

The ISL8117DEMO1Z is a compact design with high efficiency and high power density.

As shown in [Figure 4 on page 3](#), 4.5V to 60V V_{IN} is supplied to J1 (+) and J2 (-). The regulated 3.3V output on J3 (+) and J5 (-) can supply up to 6A to the load.

Operating Range

The input voltage range is from 4.5V to 60V for an output voltage of 3.3V. The rated load current is 6A with the OCP point set at minimum 8A at room temperature ambient conditions.

The temperature operating range of ISL8117 is -40°C to $+125^{\circ}\text{C}$. Please note that airflow is needed for higher temperature ambient conditions.

Layout Guidelines

Careful attention to layout requirements is necessary for successful implementation of an ISL8117 based DC/DC converter. The ISL8117 switches at a very high frequency and therefore the switching times are very short. At these switching frequencies, even the shortest trace has significant impedance. Also, the peak gate drive current rises significantly in an extremely short time. Transition speed of the current from one device to another causes voltage spikes across the interconnecting impedances and parasitic circuit elements. These voltage spikes can degrade efficiency, generate EMI and increase device overvoltage stress and ringing. Careful component selection and proper PC board layout minimizes the magnitude of these voltage spikes.

There are three sets of critical components in a DC/DC converter using the ISL8117: the controller, the switching power components and the small signal components. The switching power components are the most critical from a layout point of view because they switch a large amount of energy which tends to generate a large amount of noise. The critical small signal components are those connected to sensitive nodes or those supplying critical bias currents. A multilayer printed circuit board is recommended.

Layout Considerations

1. The input capacitors, upper FET, lower FET, inductor and output capacitor should be placed first. Isolate these power components on dedicated areas of the board with their ground terminals adjacent to one another. Place the input high frequency decoupling ceramic capacitors very close to the MOSFETs.
2. If signal components and the IC are placed in a separate area to the power train, it is recommend to use full ground planes in the internal layers with shared SGND and PGND to simplify the layout design. Otherwise, use separate ground planes for power ground and small signal ground. Connect the SGND and PGND together close to the IC. **DO NOT** connect them together anywhere else.
3. The loop formed by the input capacitor, the top FET and the bottom FET must be kept as small as possible.
4. Ensure the current paths from the input capacitor to the MOSFET, to the output inductor and the output capacitor are as short as possible with maximum allowable trace widths.
5. Place the PWM controller IC close to the lower FET. The LGATE connection should be short and wide. The IC can be best placed over a quiet ground area. Avoid switching ground loop currents in this area.
6. Place VCC5V bypass capacitor very close to the VCC5V pin of the IC and connect its ground to the PGND plane.
7. Place the gate drive components (optional BOOT diode and BOOT capacitors) together near the controller IC.
8. The output capacitors should be placed as close to the load as possible. Use short wide copper regions to connect output capacitors to load to avoid inductance and resistances.
9. Use copper filled polygons or wide but short trace to connect the junction of upper FET, lower FET and output inductor. Also keep the PHASE node connection to the IC short. **DO NOT** unnecessarily oversize the copper islands for the PHASE node. Since the phase nodes are subjected to very high dv/dt voltages, the stray capacitor formed between these islands and the surrounding circuitry will tend to couple switching noise.
10. Route all high speed switching nodes away from the control circuitry.
11. Create a separate small analog ground plane near the IC. Connect the SGND pin to this plane. All small signal grounding paths including feedback resistors, current limit setting resistor, soft-starting capacitor and EN pull-down resistor should be connected to this SGND plane.
12. Separate the current sensing trace from the PHASE node connection.
13. Ensure the feedback connection to the output capacitor is short and direct.

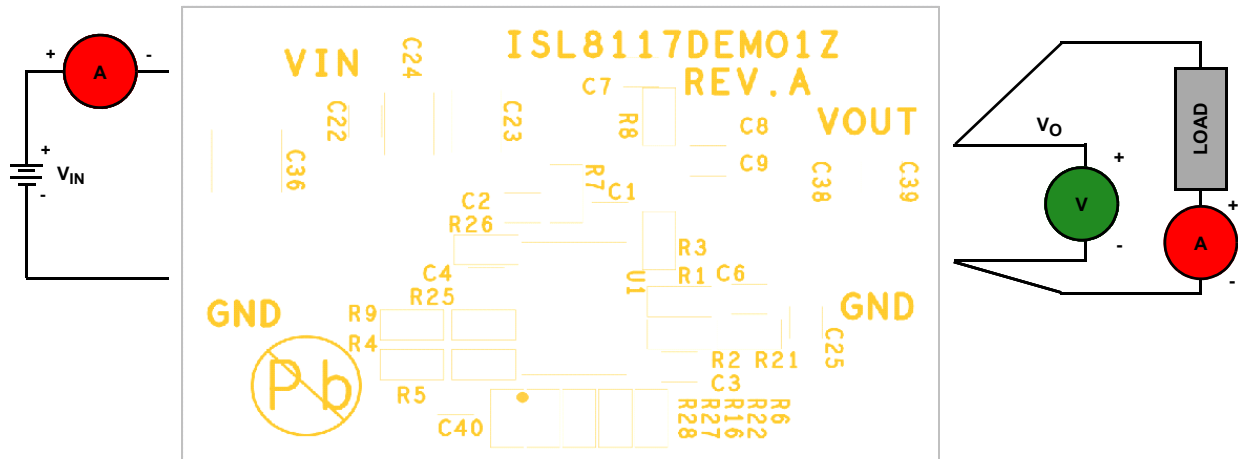

FIGURE 4. PROPER TEST SETUP

Typical Demonstration Board Performance Curves $V_{IN} = 24V, V_{OUT} = 3.3V$, unless otherwise noted.

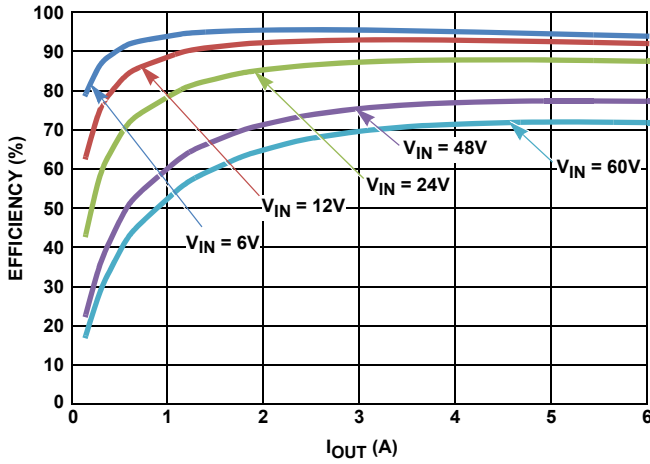

FIGURE 5. CCM EFFICIENCY vs LOAD

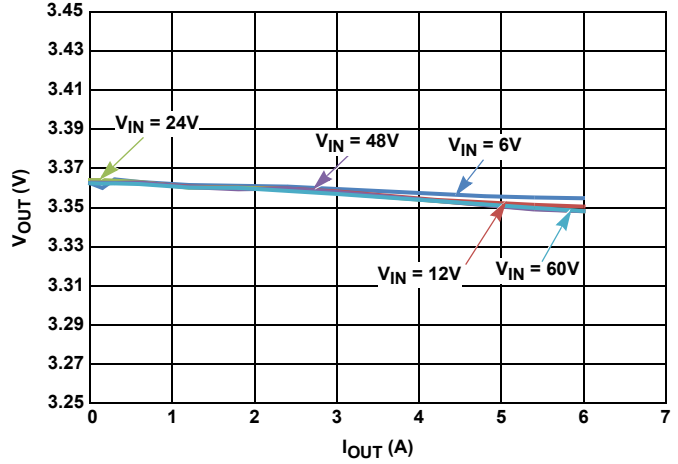

FIGURE 6. CCM LOAD REGULATION

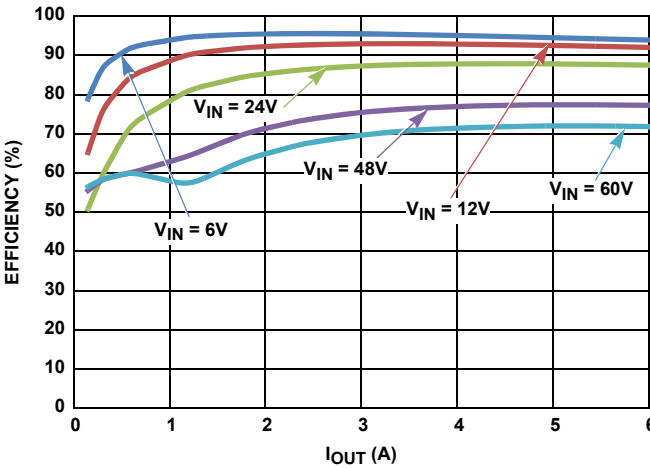

FIGURE 7. DEM EFFICIENCY vs LOAD

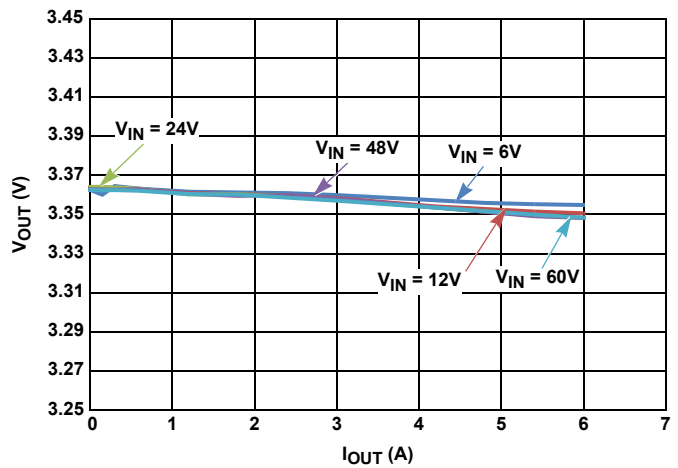

FIGURE 8. DEM LOAD REGULATION

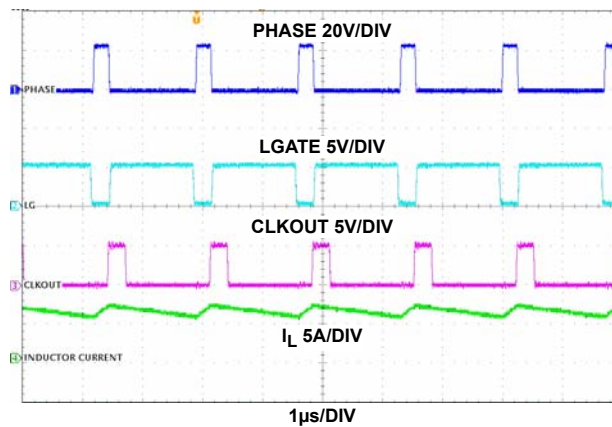

FIGURE 9. PHASE, LGATE, CLKOUT AND INDUCTOR CURRENT WAVEFORMS, $V_{IN} = 24V, I_O = 6A$

Typical Demonstration Board Performance Curves $V_{IN} = 24V, V_{OUT} = 3.3V$, unless otherwise noted. (Continued)

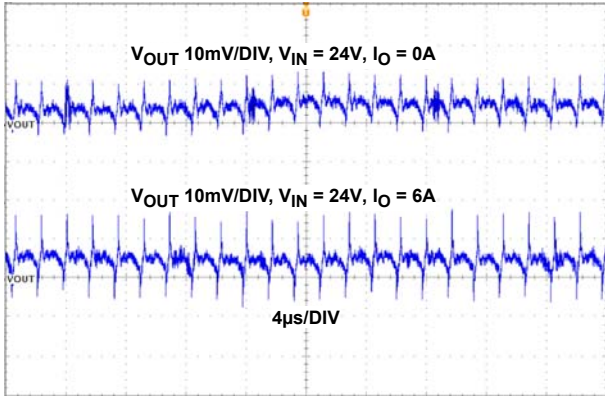

FIGURE 10. OUTPUT RIPPLE, CCM MODE

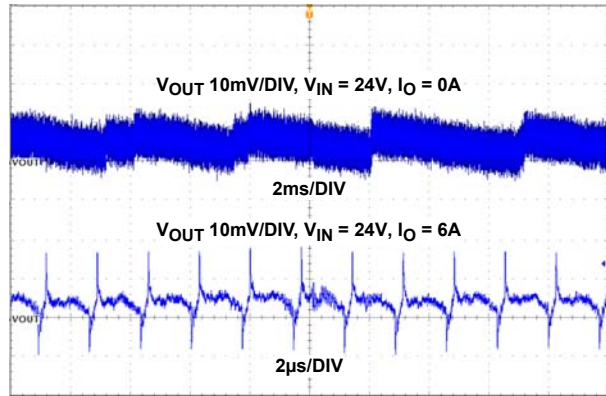

FIGURE 11. OUTPUT RIPPLE, DEM MODE

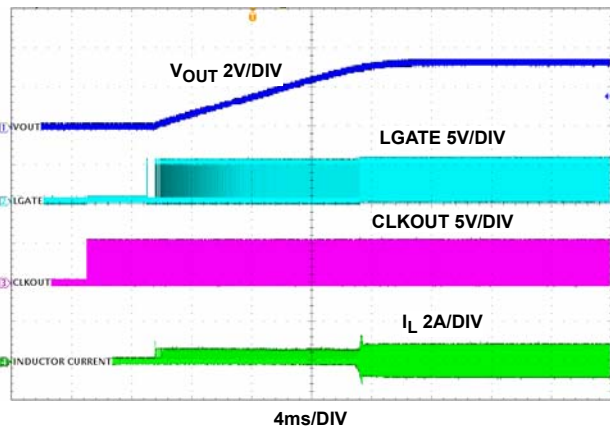

FIGURE 12. CCM START-UP WAVEFORMS: $V_{IN} = 24V, I_O = 0A$

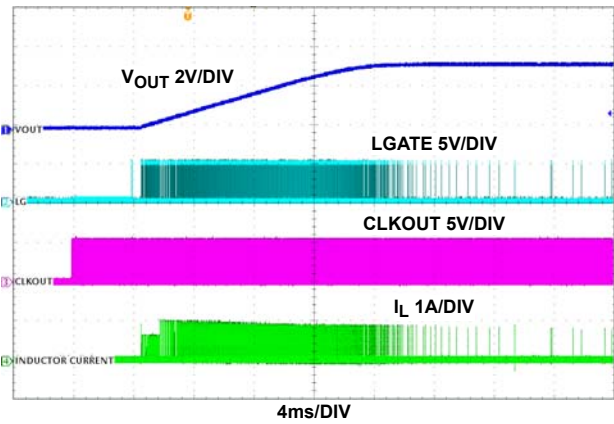

FIGURE 13. DEM START-UP WAVEFORMS: $V_{IN} = 24V, I_O = 0A$

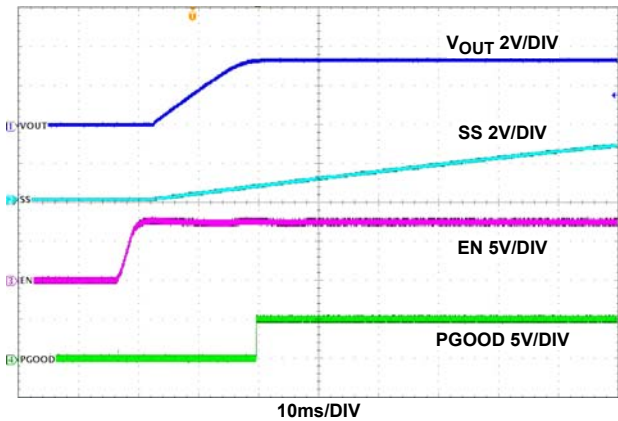

FIGURE 14. CCM START-UP WAVEFORMS: $V_{IN} = 24V, I_O = 0A$

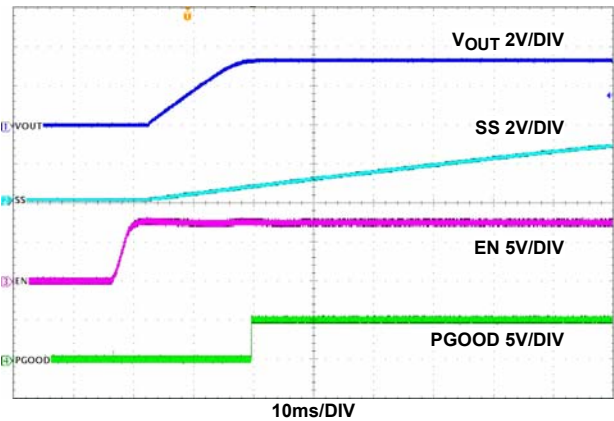

FIGURE 15. DEM START-UP WAVEFORMS: $V_{IN} = 24V, I_O = 0A$

Typical Demonstration Board Performance Curves $V_{IN} = 24V, V_{OUT} = 3.3V$, unless otherwise noted. (Continued)

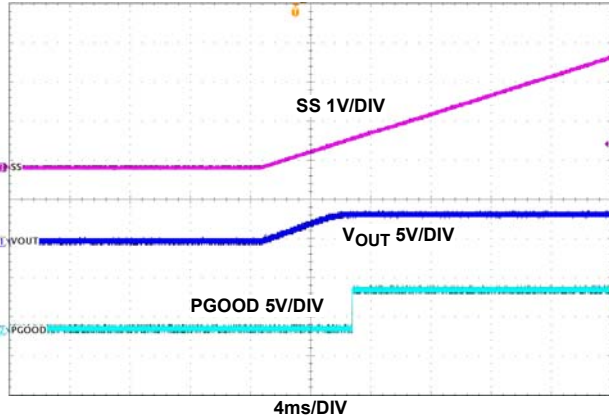

FIGURE 16. TRACKING WAVEFORMS, $V_{IN} = 24V, I_O = 0A$

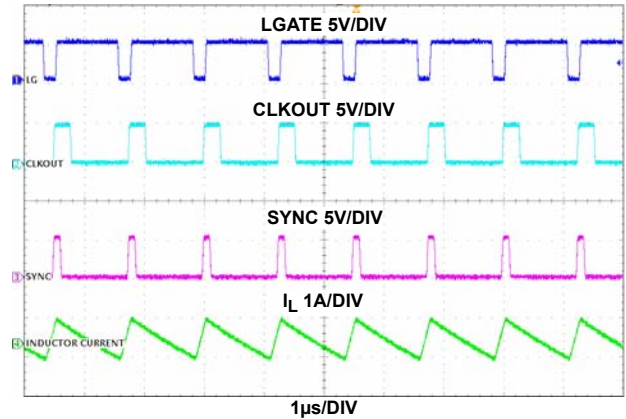

FIGURE 17. FREQUENCY SYNCHRONIZATION WAVEFORMS, $V_{IN} = 24V, I_O = 0A$

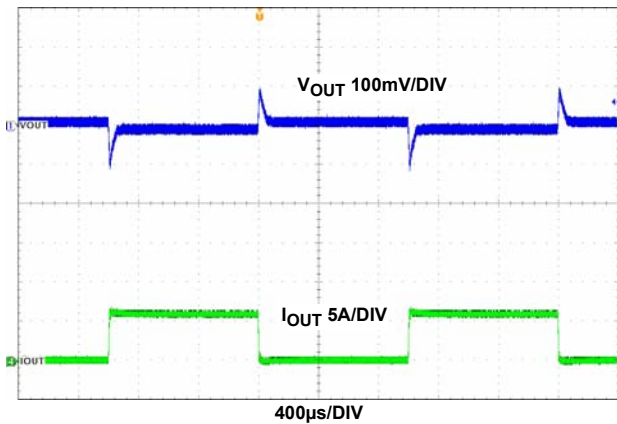

FIGURE 18. LOAD TRANSIENT; $V_{IN} = 24V, I_O = 0A$ TO $6A, 1A/\mu s$, CCM MODE

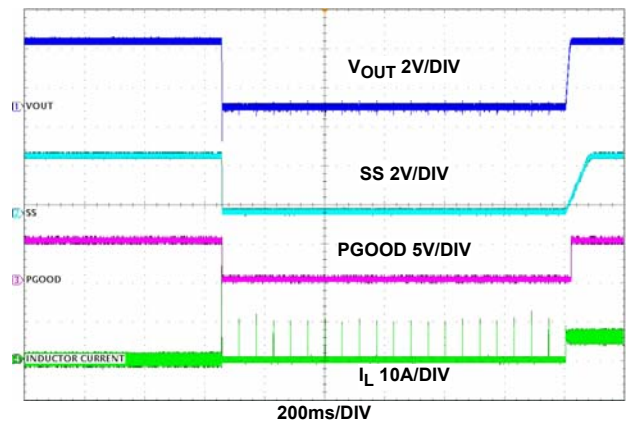

FIGURE 19. SHORT-CIRCUIT WAVEFORMS, $V_{IN} = 24V$

Schematic

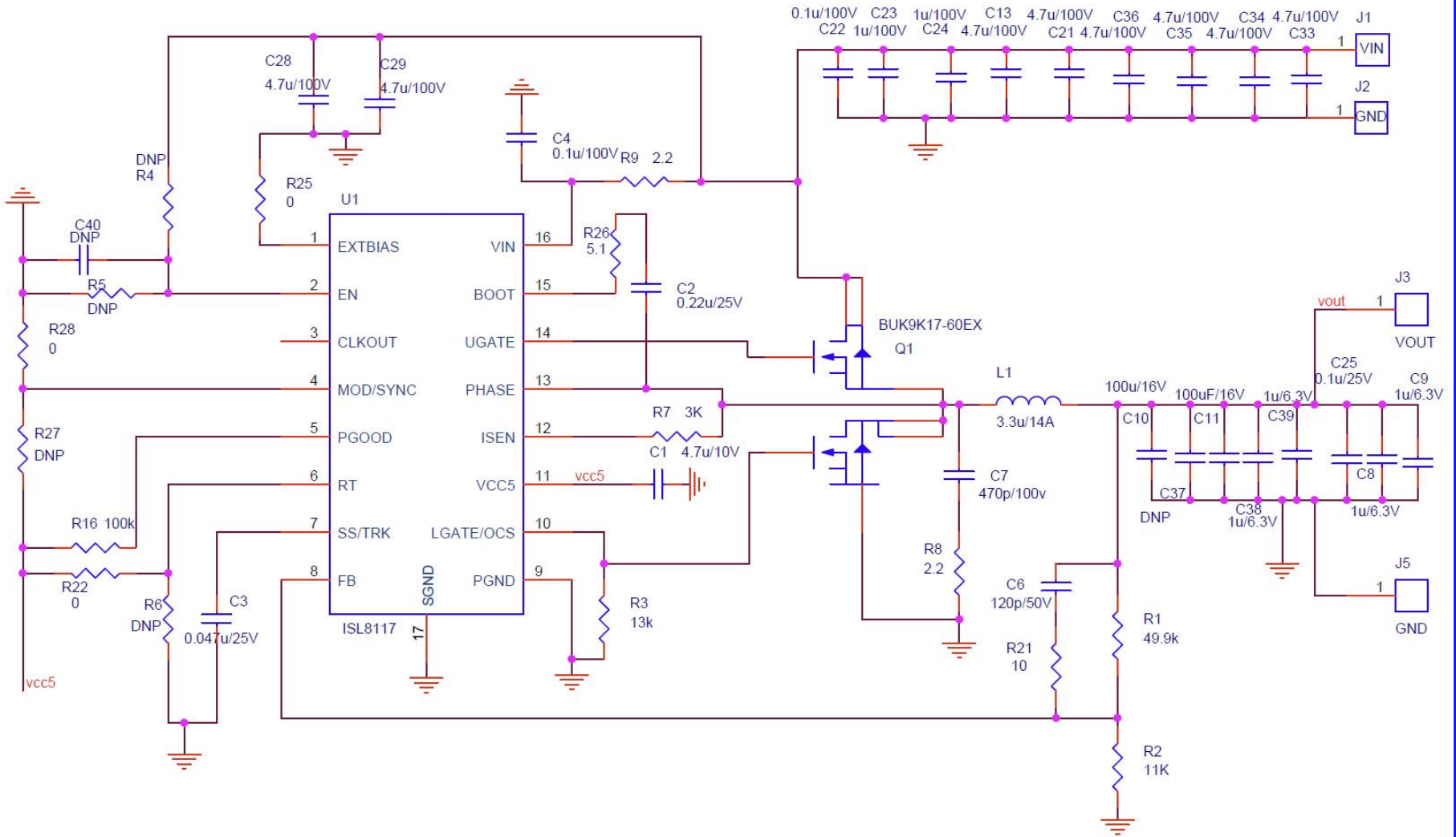

FIGURE 20. ISL8117DEMO1Z SCHEMATIC

ISL8117DEMO1Z Bill of Materials

PART NUMBER	QTY	UNITS	REFERENCE DESIGNATOR	DESCRIPTION	MANUFACTURER	MANUFACTURER PART
ISL8117DEMO1ZREVAPCB	1	ea		PWB-PCB, ISL8117DEMO1Z, REVB, ROHS	SHENZHEN MULTILAYER PCB TECHNOLOGY CO., LTD	ISL8117DEMO1ZREVAPCB
GRM32EC70J107ME15L-T	2	ea	C10, C11	CAP, SMD, 1210, 100µF, 6.3V, 20%, X7S, ROHS	MURATA	GRM32EC70J107ME15L
H1045-00104-100V10-T	2	ea	C4, C22	CAP, SMD, 0603, 0.1µF, 100V, 10%, X7R, ROHS	VENKEL	C0603X7R101-104KNE
H1045-00104-25V10-T	1	ea	C25	CAP, SMD, 0603, 0.1µF, 25V, 10%, X7R, ROHS	MURATA	GRM39X7R104K025AD
H1045-00105-6R3V10-T	4	ea	C8, C9, C38, C39	CAP, SMD, 0603, 1µF, 6.3V, 10%, X5R, ROHS	PANASONIC	ECJ1VB0J105K
H1045-00121-50V5-T	1	ea	C6	CAP, SMD, 0603, 120pF, 50V, 5%, COG, ROHS	TDK	C1608COG1H121J080AA
H1045-00224-25V10-T	1	ea	C2	CAP, SMD, 0603, 0.22µF, 25V, 10%, X7R, ROHS	TDK	C1608X7R1E224K
H1045-00471-100V10-T	1	ea	C7	CAP, SMD, 0603, 470pF, 100V, 10%, X7R, ROHS	VISHAY	VJ0603Y471KXBA
H1045-00473-25V10-T	1	ea	C3	CAP, SMD, 0603, 0.047µF, 25V, 10%, X7R, ROHS	MURATA	GRM188R71E473KA01D
H1046-00475-10V20-T	1	ea	C1	CAP, SMD, 0805, 4.7µF, 10V, 20%, X5R, ROHS	AVX	0805ZD475MAT2A
H1065-00105-100V10-T	2	ea	C23, C24	CAP, SMD, 1206, 1µF, 100V, 10%, X7R, ROHS	VENKEL	C1206X7R101-105KNE
H1082-00475-100V10-T	8	ea	C13, C21, C28, C29, C33, C34, C35, C36	CAP, SMD, 1210, 4.7µF, 100V, 10%, X7S, ROHS	TDK	CGA6M3X7S2A475K200AB
H1082-DNP	0	ea	C37	CAP, SMD, 1210, DNP-PLACE HOLDER, ROHS		
7443340330	1	ea	L1	COIL-PWR INDUCTOR, SMD, 8.4x7.9, 3.3µH, 20%, 14A, ROHS	Würth Electronics	7443340330
1514-2	4	ea	J1, J2, J3, J5	CONN-TURRET, TERMINAL POST, TH, ROHS	KEYSTONE	1514-2
ISL8117FVEZ	1	ea	U1	IC-55V SWITCHING CONTROLLER, 16P, HTSSOP, ROHS	INTERSIL	ISL8117FVEZ
BUK9K17-60EX-T	1	ea	Q1	TRANSIST-MOS, DUAL N-CHANNEL, SMD, 8P, 56LPAK, 60V, 26A, ROHS	NXP SEMICONDUCTOR	BUK9K17-60EX
H2511-00100-1/10W1-T	1	ea	R21	RES, SMD, 0603, 10Ω, 1/10W, 1%, TF, ROHS	KOA	RK73H1JT10R0F
H2511-002R2-1/10W1-T	2	ea	R8, R9	RES, SMD, 0603, 2.2Ω, 1/10W, 1%, TF, ROHS	PANASONIC	ERJ-3RQF2R2V
H2511-005R1-1/10W1-T	1	ea	R26	RES, SMD, 0603, 5.1Ω, 1/10W, 1%, TF, ROHS	VENKEL	CR0603-10W-05R1FT
H2511-00R00-1/10W-T	3	ea	R22, R25, R28	RES, SMD, 0603, 0Ω, 1/10W, TF, ROHS	VENKEL	CR0603-10W-000T
H2511-01003-1/10W1-T	1	ea	R16	RES, SMD, 0603, 100k, 1/10W, 1%, TF, ROHS	VENKEL	CR0603-10W-1003FT
H2511-01102-1/10W1-T	1	ea	R2	RESISTOR, SMD, 0603, 11k, 1/10W, 1%, TF, ROHS	PANASONIC	ERJ-3EKF1102V

ISL8117DEMO1Z Bill of Materials (Continued)

PART NUMBER	QTY	UNITS	REFERENCE DESIGNATOR	DESCRIPTION	MANUFACTURER	MANUFACTURER PART
H2511-03001-1/10W1-T	1	ea	R7	RES, SMD, 0603, 3k, 1/10W, 1%, TF, ROHS	YAGEO	RC0603FR-073KL
H2511-04992-1/10W1-T	1	ea	R1	RES, SMD, 0603, 49.9k, 1/10W, 1%, TF, ROHS	VENKEL	CR0603-10W-4992FT
H2511-DNP	0	ea	R4, R5, R6, R27	RES, SMD, 0603, DNP-PLACE HOLDER, ROHS		
RC0603FR-0713KL	1		R3	RES SMD 13kΩ 1% 1/10W 0603		RC0603FR-0713KL
DNP	0	ea	C40	DO NOT POPULATE OR PURCHASE		

ISL8117DEMO1Z PCB Layout

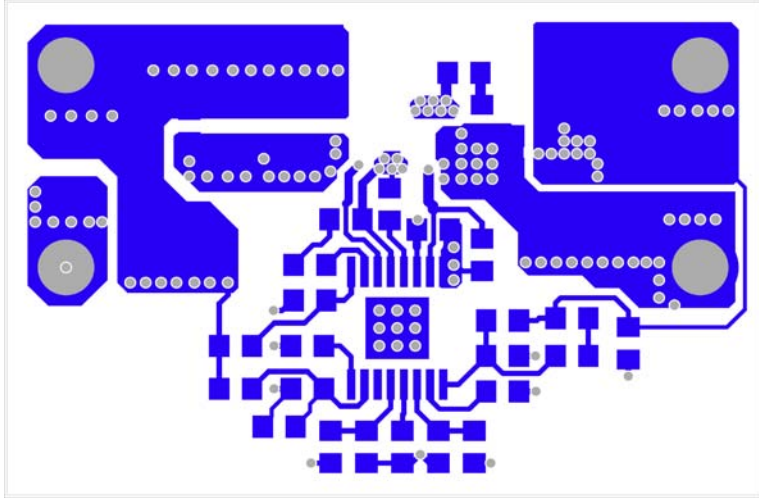

FIGURE 21. TOP LAYER

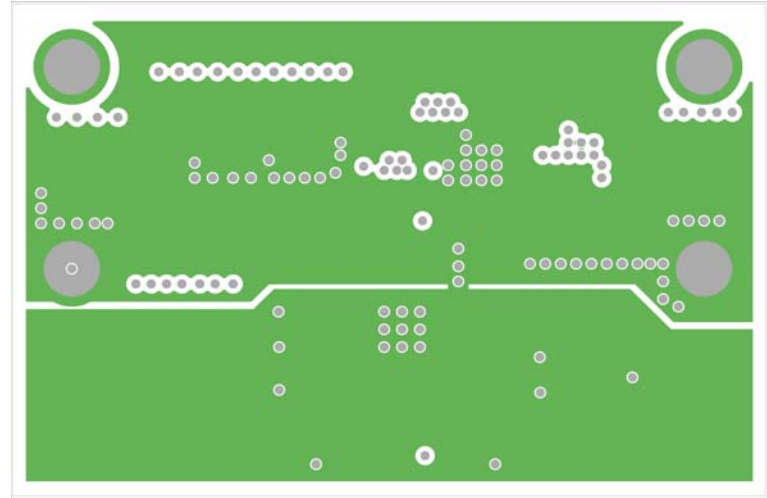

FIGURE 22. SECOND LAYER (SOLID GROUND)

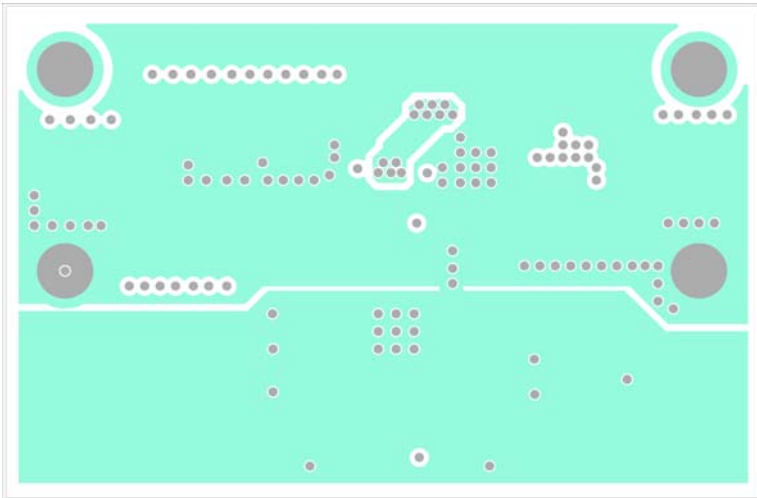

FIGURE 23. THIRD LAYER

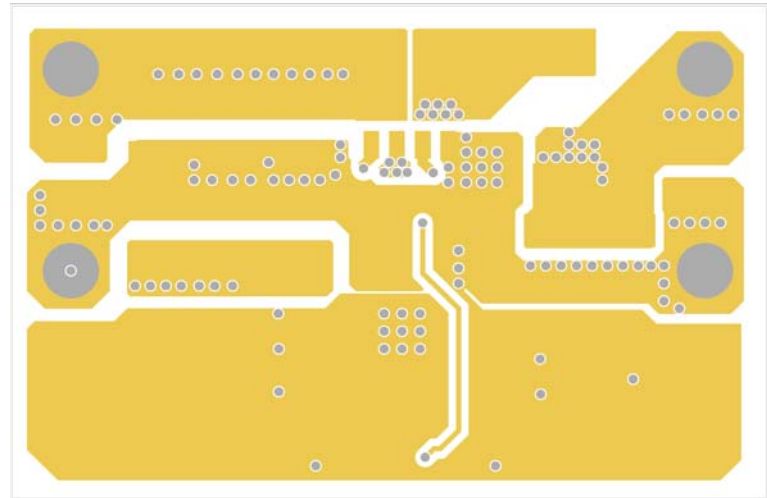

FIGURE 24. BOTTOM LAYER

