

## ISL8120EVAL4Z

### Evaluation Board Setup Procedure

AN1607  
Rev.2.00  
Jul 1, 2016

## Description

The [ISL8120](#) integrates two voltage-mode synchronous buck PWM controllers. It can be used either for dual independent outputs or a 2-phase single-output regulator.

The ISL8120EVAL4Z evaluation board is used for performance demo of 2/n-phase single-output applications. This application note introduces the setup procedure and performance of the ISL8120EVAL4Z evaluation board.

The ISL8120EVAL3Z evaluation board is for performance demo of dual independent outputs and DDR applications. Refer to application note [AN1528](#) "ISL8120EVAL3Z Evaluation Board Setup Procedure" for details of the ISL8120EVAL3Z board.

## References

- [ISL8120](#) datasheet

## Ordering Information

PART NUMBER	DESCRIPTION
ISL8120EVAL4Z	ISL8120EVAL4Z evaluation board

## Recommended Equipment

- 0V to 22V power supply with at least 20A source current capability, battery, or notebook AC adapter.
- Two electronic loads capable of sinking current up to 30A.
- Digital multimeters (DMMs).
- 100MHz quad-trace oscilloscope.

## Quick Start

1. Ensure that the circuit is correctly connected to the supply and loads prior to applying any power.
2. Adjust the input supply to be 12V. Turn on the input power supply.
3. Verify the output voltage is 1.2V. If PGOOD is set high, the LED2 will be green. If PGOOD is set low, the LED2 will be red. TP4 is the test post to monitor PGOOD.

## Circuits Description

J1 and J2 are the input power terminals.

J3 and J4 are output lugs for load connections.

The input electrolytic capacitors are used to handle the input current ripples.

Two upper and two lower Renesas "speed" series LFPK MOSFETs are used for each phase.

320nH PULSE surface mount inductors are used for each phase. Under the 500kHz setup, the inductor current peak-to-peak ripple is 7.5A at 12V input and 1.2V output.

Four SANYO POSCAP 2R5TPF470M7L (7mΩ) are used as output E-caps.

TP2 and TP3 are remote sense posts. These pins can be used to monitor and evaluate the system voltage regulations. If the user wants to use these test posts for remote sense, the  $R_{29}$  and  $R_{31}$  need to be changed to higher values, such as 10Ω. Also, the related voltage sense divider needs to be increased to a higher resistance, such as 1k.

TP1 is a test socket to hold the scope probe to check the output waveforms.

JP9 is used to disable the part.

JP6 is for connection of inputs of clock signal for the part to be synchronized with.

JP5 is used for connection of ISHARE signals of multiple boards in parallel operation applications.

JP3, JP4,  $R_{15}$  and  $R_{17}$  are used to set up the phase shift between the 2 phases of the IC.

$R_{27}$  is used to isolate the noise at PVCC caused by driving. In 3.3V applications, it is recommended to short  $R_{27}$  to 0 in order to prevent VCC from dropping below POR under low input voltage.

## Evaluating the Other Output Voltage

The ISL8120EVAL4Z kit output is preset to 1.2V/50A.  $V_{OUT1}$  can also be adjusted between 0.6V to 3V by changing the value of  $R_{26}$  and  $R_6$  for  $V_{OUT}$ , as given by [Equation 1](#). The same rule applies for  $V_{OUT2}$ .

$$R_{26} = \frac{R_6}{(V_{OUT}/V_{REF}) - 1} \quad \text{where } V_{REF} = 0.6V \quad (\text{EQ. 1})$$

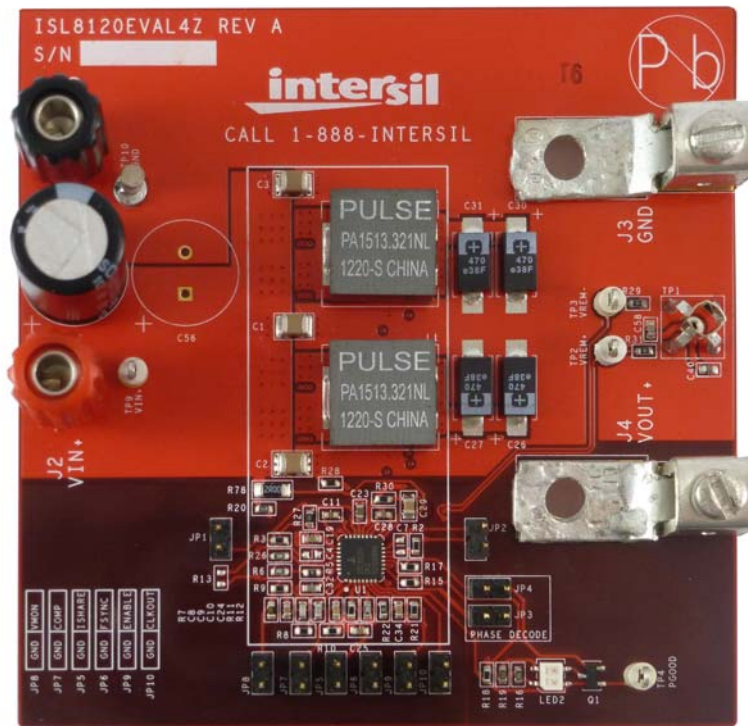

FIGURE 1. ISL8120EVAL4Z EVALUATION BOARD

## Programming the Input Voltage UVLO and its Hysteresis

By programming the voltage divider at the EN/FF pin connected to the input rail, the input UVLO and its hysteresis can be programmed. The ISL8120EVAL4Z has R<sub>20</sub> 4.32k and R<sub>21</sub> 1.62k; the IC will be disabled when input voltage drops below 2.94V and will restart until V<sub>IN</sub> recovers to be above 3.2V.

For 12V applications, it is suggested to have R<sub>20</sub> 24.9k and R<sub>21</sub> 2.43k, of which the IC is disabled when the input voltage drops below 9V and will restart until V<sub>IN</sub> recovers to be above 10.5V.

Refer to the [ISL8120](#) datasheet to program the UVLO falling threshold and hysteresis. The equations are restated here in [Equations 2](#) and [3](#), where R<sub>UP</sub> and R<sub>DOWN</sub> are the upper and lower resistors of the voltage divider at EN/FF pin, V<sub>HYS</sub> is the desired UVLO hysteresis and V<sub>FTH</sub> is the desired UVLO falling threshold.

$$R_{UP} = \frac{V_{HYS}}{I_{HYS}} \quad \text{where } I_{HYS} = 2 \times 30 \mu\text{A} \quad (\text{EQ. 2})$$

$$R_{DOWN} = \frac{R_{UP} \cdot V_{ENREF}}{V_{FTH} - V_{ENREF}} \quad \text{where } V_{ENREF} = 0.8\text{V} \quad (\text{EQ. 3})$$

Note the ISL8120 EN/FF pin is a triple function pin and the voltages applied to the EN/FF pins are also fed to adjust the amplitude of each channel's individual sawtooth.

## Parallel Operation for Current Sharing Application

The ISL8120 regulator outputs can be paralleled with current sharing control capability. The configuration for parallel operation is shown in Typical Application VIII in the datasheet. For this evaluation board, follow these steps to set up the parallel operation of 2 boards:

1. Change R<sub>5</sub> to 100Ω for both boards.
2. Use 2 wires (ISHARE, GND) connecting the ISHARE signals of the 2 boards through JP5.
3. Use 2 wires (EN/FF, GND) connecting the EN/FF signals of the 2 boards through JP9.
4. Use 2 wires connecting from JP10 (CLKOUT, GND) of one board to JP6 (FSYNC, GND) of another board.
5. Connecting the power supply to the inputs of the 2 boards.
6. Connecting the output of the 2 boards together and apply the loads.

[Figure 2](#) shows the setup picture of 2 boards in parallel operation.

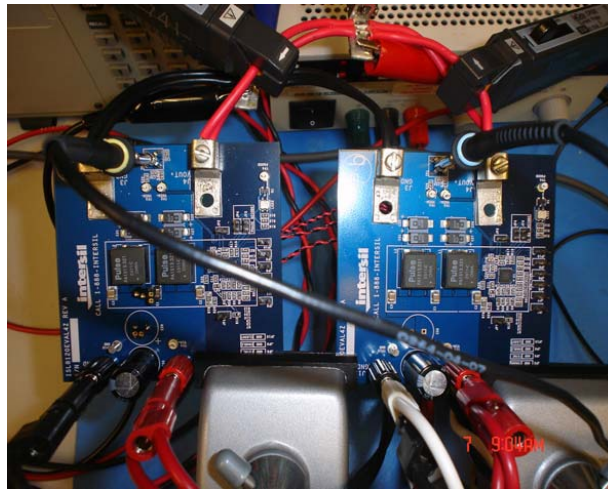
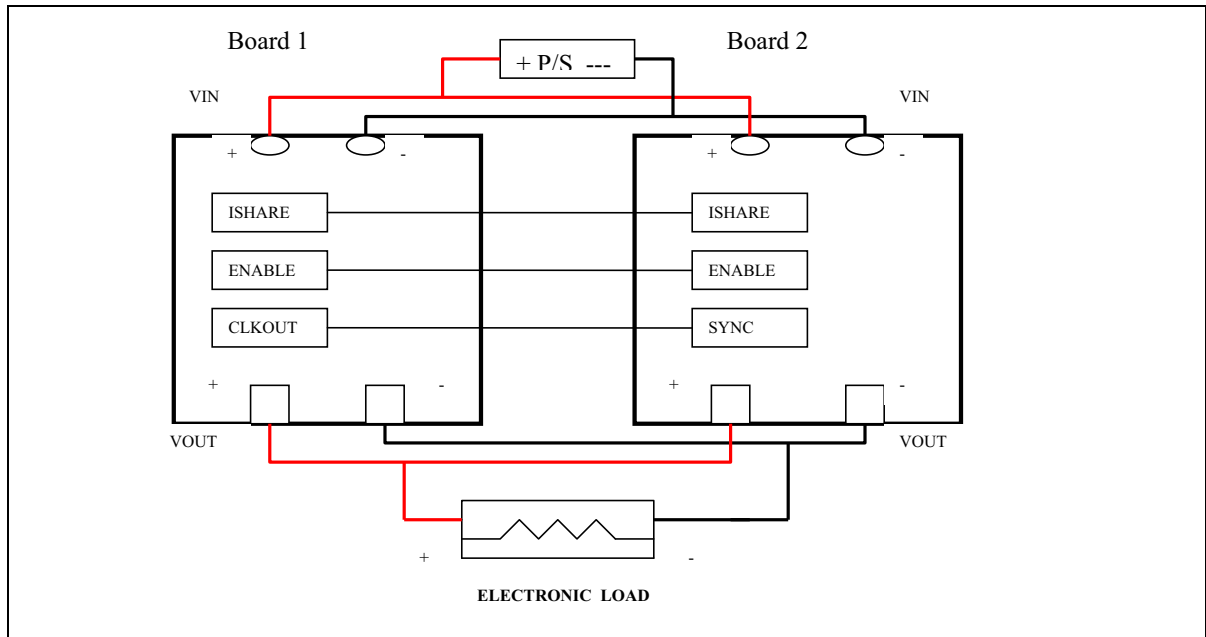
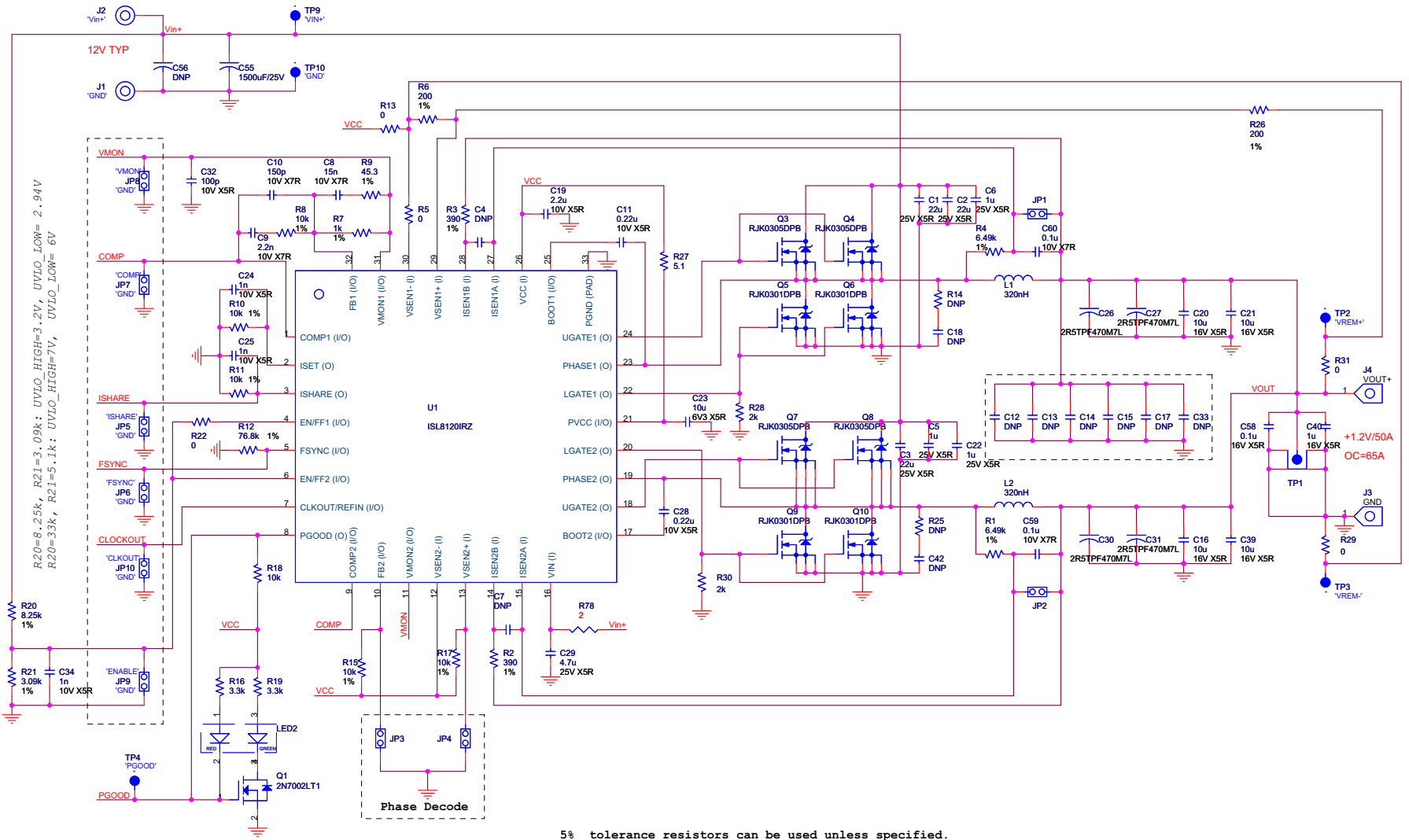

FIGURE 2. PARALLEL OPERATION SETUP

# ISL8120EVAL4Z Schematic



5% tolerance resistors can be used unless specified.

FIGURE 3. ISL8120EVAL4Z SCHEMATIC

## ISL8120EVAL4Z Bill of Materials

QTY	UNITS	REFERENCE DESIGNATOR	DESCRIPTION	MANUFACTURER	MANUFACTURER PART
1	ea		PWB-PCB, ISL8120EVAL4Z, REVA, QFN, ROHS	TBD	ISL8120EVAL4ZREVAPCB
1	ea	C32	CAP, SMD, 0603, 100pF, 50V, 5%, COG, ROHS	PANASONIC	ECJ-1VC1H101J
3	ea	C24, C25, C34	CAP, SMD, 0603, 1000pF, 16V, 10%, X7R, ROHS	VENKEL	C0603X7R160102KNE
3	ea	C58-C60	CAP, SMD, 0603, 0.1μF, 16V, 10%, X7R, ROHS	MURATA	GRM39X7R104K016AD
1	ea	C40	CAP, SMD, 0603, 1μF, 16V, 10%, X5R, ROHS	MURATA	GRM188R61C105KA12D
1	ea	C23	CAP, SMD, 0603, 10μF, 6.3V, 20%, X5R, ROHS	TDK	C1608X5R0J106M
1	ea	C10	CAP, SMD, 0603, 150pF, 50V, 5%, NP0, ROHS	PANASONIC	ECJ-1VC1H151J
1	ea	C8	CAP, SMD, 0603, 15000pF, 16V, 10%, X7R, ROHS	VENKEL	0603X7R160-153KNE
1	ea	C9	CAP, SMD, 0603, 2200pF, 50V, 5%, COG, ROHS	MURATA	GRM1885C1H222JA01D
2	ea	C11, C28	CAP, SMD, 0603, 0.22μF, 10V, 10%, X7R, ROHS	AVX	0603ZC224KAT2A
1	ea	C19	CAP, SMD, 0603, 2.2μF, 16V, 10%, X5R, ROHS	MURATA	GRM188R61C225KE15D
0	ea	C4, C7, C18, C42	CAP, SMD, 0603, DNP-PLACE HOLDER, ROHS		
3	ea	C5, C6, C22	CAP, SMD, 0805, 1.0μF, 25V, 10%, X5R, ROHS	AVX	08053C105KAT2A
1	ea	C29	CAP, SMD, 0805, 4.7μF, 25V, 10%, X5R, ROHS	MURATA	GRM21BR61E475KA12L
4	ea	C16, C20, C21, C39	CAP, SMD, 1206, 10μF, 16V, 10%, X5R, ROHS	VENKEL	C1206X5R160-106KNE(Pb-FREE)
3	ea	C1, C2, C3	CAP, SMD, 1210, 22μF, 25V, 10%, X5R, ROHS		
0	ea	C12, C13, C14, C15, C17, C33	CAP, SMD, 1210, DNP-PLACE HOLDER, ROHS		
1	ea	C55	CAP, RADIAL, 12.5x25, 1500μF, 25V, 20%, ALUM.ELEC., ROHS	RUBYCON	25ZL1500M12.5X25
0	ea	DNP (C56)	CAP, RADIAL, 12.5x25, 1500μF, 25V, 20%, ALUM.ELEC., ROHS	RUBYCON	25ZL1500M12.5X25
4	ea	C26, C27, C30, C31	CAP, POSCAP, SMD, 7.3x4.3, 470μF, 2.5V, 20%, 7mΩ, ROHS	SANYO	2R5TPF470M7L
2	ea	L1, L2	COIL-PWR INDUCTOR, SMD, 13mm, 320nH, 20%, 45A, Pb-Free	PULSE	PA1513.321NLT
1	ea	J2 (SEE ASSEMBLY INSTRUCTIONS)	CONN-GEN, BIND.POST, INSUL-RED, THMBNUT-GND	JOHNSON COMPONENTS	111-0702-001
1	ea	J1 (SEE ASSEMBLY INSTRUCTIONS)	CONN-GEN, BIND.POST, INSUL-BLK, THMBNUT-GND	JOHNSON COMPONENTS	111-0703-001
1	ea	TP1	CONN-SCOPE PROBE TEST PT, COMPACT, PCB MNT, ROHS	TEKTRONIX	131-5031-00
1	ea	TP10	CONN-TURRET, TERMINAL POST, TH, ROHS	KEYSTONE	1514-2
4	ea	TP2, TP3, TP4, TP9	CONN-COMPACT TEST PT, VERTICAL, WHT, ROHS	KEYSTONE	5007
10	ea	JP1-JP10	CONN-HEADER, 1x2, RETENTIVE, 2.54mm, 0.230x0.120, ROHS"	BERG/FCI	69190-202HLF
1	ea	LED2	LED, SMD, 3x2.5mm, 4P, RED/GREEN, 12/20MCD, 2V	LUMEX	SSL-LXA3025IGC-TR
1	ea	U1	IC-DUAL PHASE PWM CONTROLLER, 32P, QFN, 5x5, ROHS	INTERSIL	ISL8120IRZ

**ISL8120EVAL4Z Bill of Materials (Continued)**

QTY	UNITS	REFERENCE DESIGNATOR	DESCRIPTION	MANUFACTURER	MANUFACTURER PART
1	ea	Q1	TRANSISTOR, N-CHANNEL, 3LD, SOT-23, 60V, 115mA, ROHS	DIODES, INC.	2N7002-7-F
4	ea	Q5, Q6, Q9, Q10	TRANSISTOR, N-CHANNEL, 5P, LFPK, 30V, 60A, ROHS	RENESAS TECHNOLOGY	RJK0301DPB
4	ea	Q3, Q4, Q7, Q8	TRANSISTOR, N-CHANNEL, 5P, LFPK, 30V, 30A, ROHS	RENESAS TECHNOLOGY	RJK0305DPB
1	ea	R27	RES, SMD, 0603, 5.1Ω, 1/10W, 1%, TF, ROHS	VISHAY/DALE	CRCW06035R10FNEA
4	ea	R5, R22, R29, R31	RES, SMD, 0603, 0Ω, 1/10W, TF, ROHS	VENKEL	CR0603-10W-000T
1	ea	R7	RES, SMD, 0603, 1k, 1/10W, 1%, TF, ROHS	PANASONIC	ERJ-3EKF1001V
6	ea	R8, R10, R11, R15, R17, R18	RES, SMD, 0603, 10k, 1/10W, 1%, TF, ROHS	KOA	RK73H1JT1002F
1	ea	R21	RES, SMD, 0603, 1.62k, 1/10W, 1%, TF, ROHS	PANASONIC	ERJ-3EKF1621V
2	ea	R6, R26	RES, SMD, 0603, 200Ω, 1/10W, 1%, TF, ROHS	VENKEL	CR0603-10W-2000FT
2	ea	R28, R30	RES, SMD, 0603, 2k, 1/10W, 1%, TF, ROHS	KOA	RK73H1JT2001F
2	ea	R16, R19	RES, SMD, 0603, 3.3kΩ, 1/10W, 1%, TF, ROHS	ROHM	MCR03EZPF3301
2	ea	R2, R3	RES, SMD, 0603, 390Ω, 1/10W, 1%, TF, ROHS	PANASONIC	ERJ-3EKF3900V
1	ea	R20	RES, SMD, 0603, 4.32k, 1/10W, 1%, TF, ROHS		
1	ea	R9	RES, SMD, 0603, 45.3Ω, 1/10W, 1%, TF, ROHS	VENKEL	CR0603-10W-45R3FT
2	ea	R1, R4	RES, SMD, 0603, 6.49k, 1/10W, 1%, TF, ROHS	PANASONIC	ERJ-3EKF6491V
1	ea	R12	RES, SMD, 0603, 76.8k, 1/10W, 1%, TF, ROHS	VENKEL	CR0603-10W-7682FT
0	ea	R13	RES, SMD, 0603, DNP-PLACE HOLDER, ROHS		
0	ea	R14, R25	RES, SMD, 0805, DNP-PLACE HOLDER, ROHS		
1	ea	R78	RES, SMD, 1206, 2Ω, 1/4W, 1%, TF, ROHS	VENKEL	CR1206-4W-02R0
2	ea	J3, J4	HDWARE, MTG, CABLE TERMINAL, 6-14AWG, LUG&SCREW, ROHS	BERG/FCI	KPA8CTP
4	ea	Bottom four corners	BUMPONS, 0.44inW x 0.20inH, DOMETOP, , BLACK	3M	SJ-5003SPBL
1	ea	Place assy in bag	BAG, STATIC, 5x8, ZIPLOC, ROHS	INTERSIL	212403-013
1	ea	a) J1, J2 - Studs from binding posts	Instructions for assembly.	INTERSIL	ASSEMBLY INSTRUCTIONS
0	ea	b) Should be cut with with appropriate	Instructions for assembly.	INTERSIL	ASSEMBLY INSTRUCTIONS
0	ea	c) Cutters and de-burred with resin backed,	Instructions for assembly.	INTERSIL	ASSEMBLY INSTRUCTIONS
0	ea	d) Aluminum oxide sander.	Instructions for assembly.	INTERSIL	ASSEMBLY INSTRUCTIONS
1	ea		LABEL-FOR SERIAL NUMBER AND BOM REV #	INTERSIL	LABEL-SERIAL NUMBER





# ISL8120EVAL4Z Board Layout (Continued)

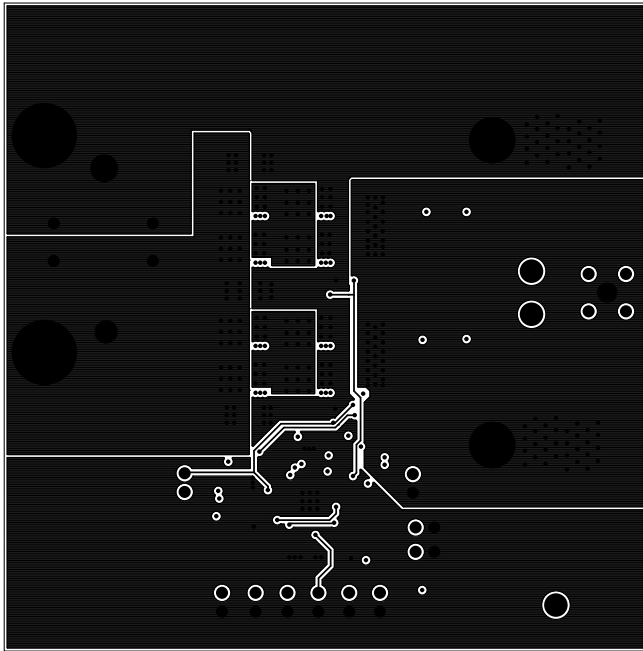

FIGURE 8. 4<sup>th</sup> LAYER

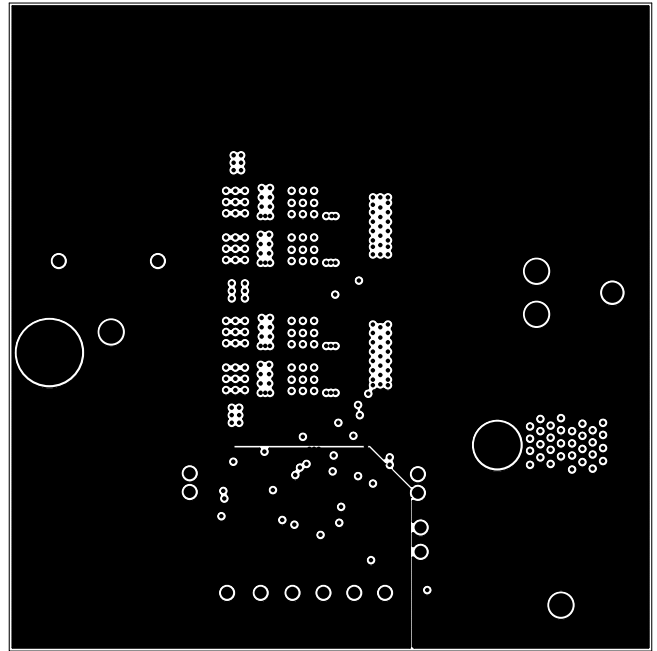

FIGURE 9. 5<sup>th</sup> LAYER

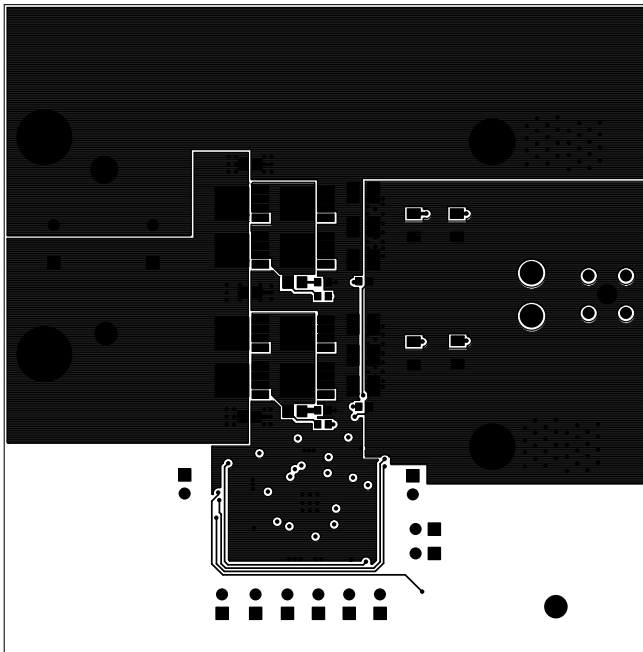

FIGURE 10. BOTTOM LAYER

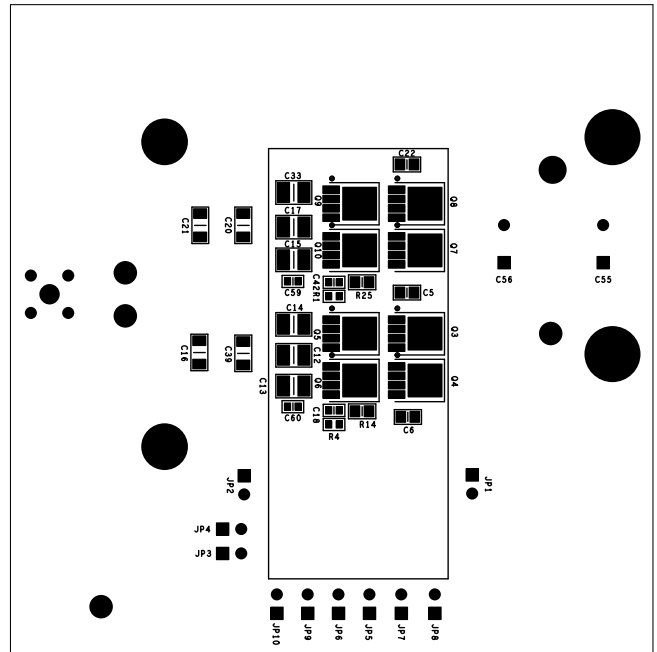

FIGURE 11. BOTTOM SILKSCREEN (MIRRORED)



# ISL8120EVAL4Z Board Layout (Continued)

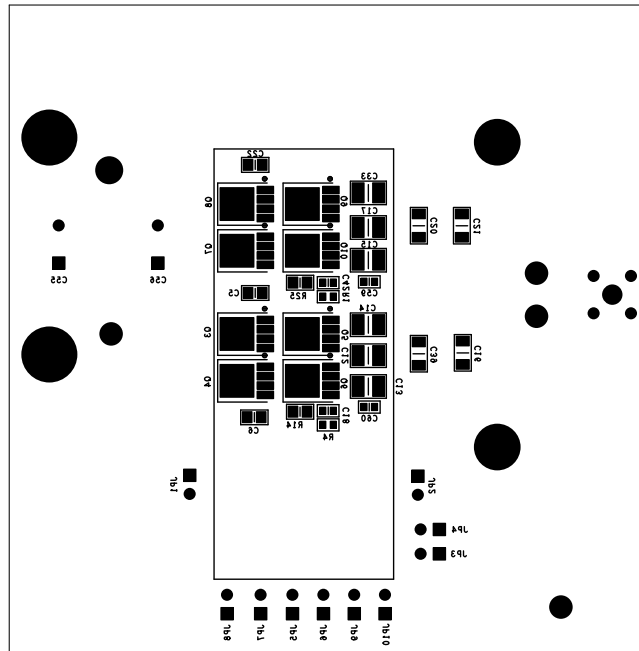

FIGURE 12. BOTTOM SILKSCREEN

### Test Data for ISL8120EVAL4Z

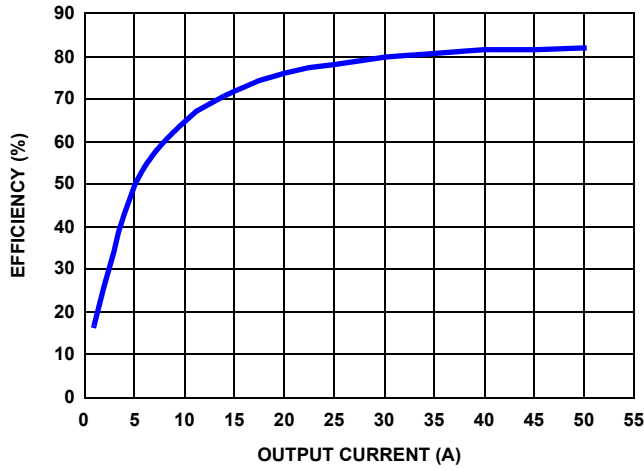

FIGURE 13. EFFICIENCY (12V  $V_{IN}$  AND 1.2V  $V_{OUT}$ )

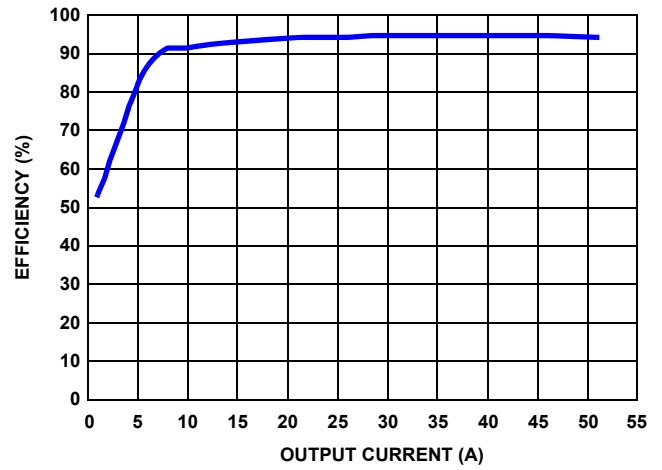

FIGURE 14. EFFICIENCY (12V  $V_{IN}$  AND 3.3V  $V_{OUT}$ )

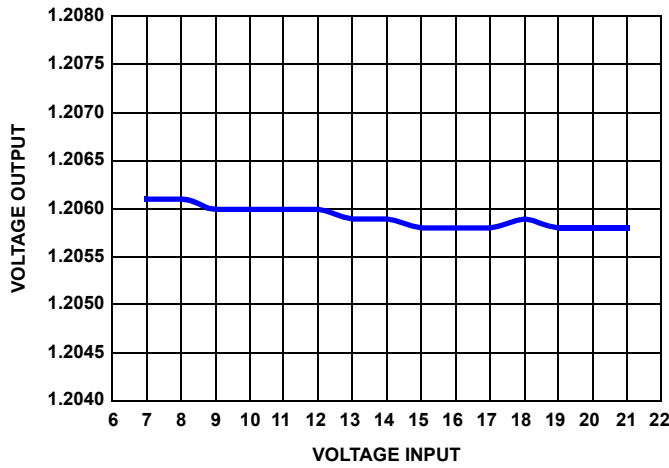

FIGURE 15. LINE REGULATION

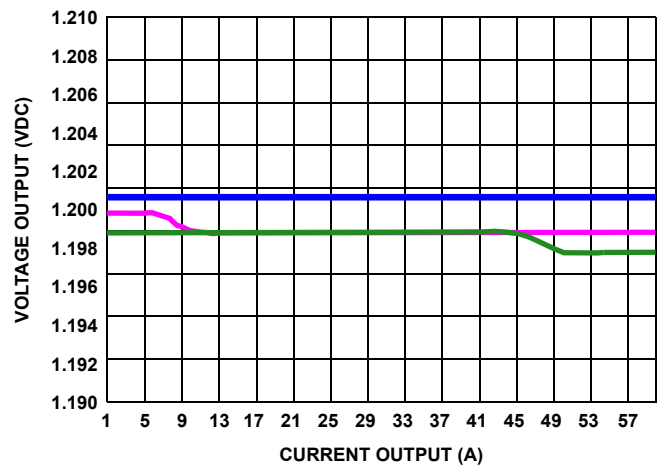

FIGURE 16. LOAD REGULATION

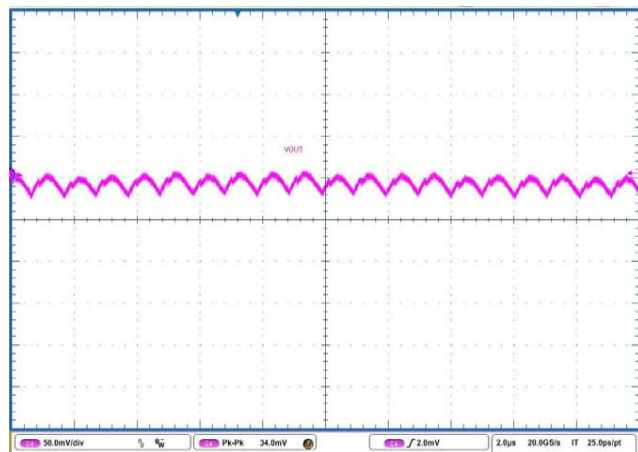

FIGURE 17. OUTPUTS RIPPLE UNDER 0A LOAD

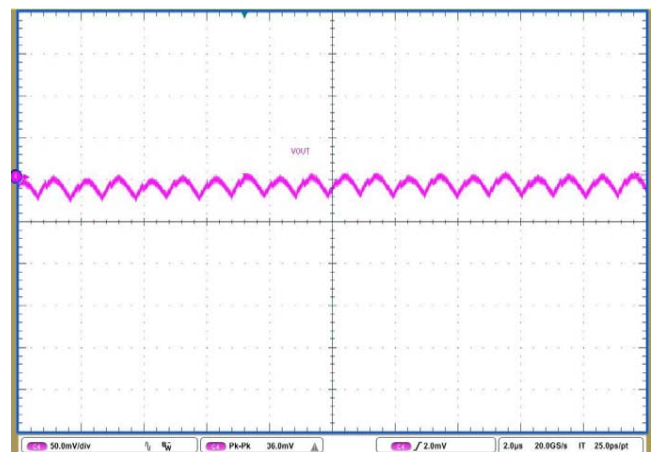
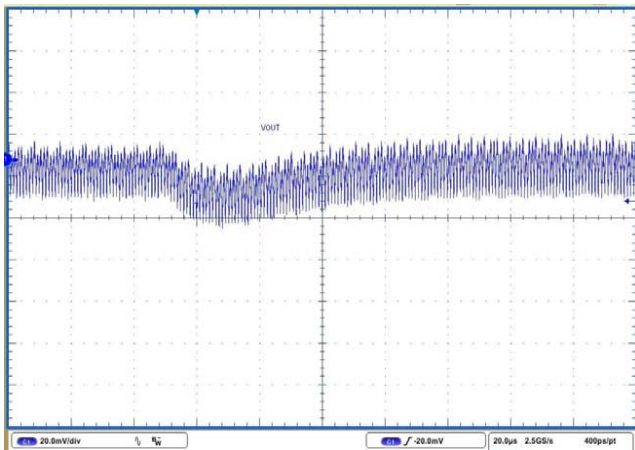
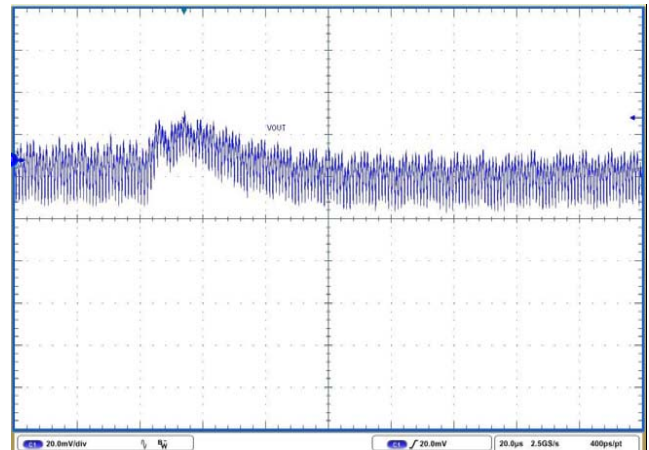

FIGURE 18. OUTPUTS RIPPLE UNDER 50A LOAD

**Test Data for ISL8120EVAL4Z (Continued)**



**FIGURE 19. LOAD TRANSIENT (0A TO 50A STEP, SLEW\_RATE = 2.5A/µs)**



**FIGURE 20. LOAD TRANSIENT (50A TO 0A STEP, SLEW\_RATE = 2.5A/µs)**

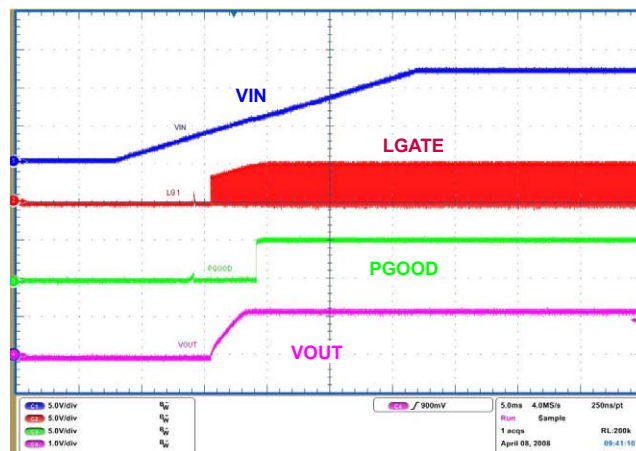

**FIGURE 21. POWER-UP UNDER 50A FULL LOAD**