

ISL85005DEMO1Z, ISL85005ADEMO1Z

Demonstration Boards User Guide

UG110
Rev.0.00
Feb 6, 2017

Description

The [ISL85005](#) and [ISL85005A](#) are 4.5V to 18V input, 5A synchronous buck regulators for applications with input voltage from multi-cell batteries or regulated 5V and 12V power rails. These devices also provide an integrated bootstrap diode for the high-side gate driver to reduce the external parts count. The ISL85005DEMO1Z and ISL85005ADEMO1Z platforms allow quick demonstration of the high performance features of the ISL85005 and ISL85005A buck regulators.

Specifications

These boards have been configured and optimized for the following operating conditions:

- Input voltage ranges from 7V to 15V
- 5V nominal output voltage
- Up to 5A output current capability
- Default internally set 500kHz switching frequency
- Default internally set 2.3ms soft-start
- Operating temperature range: -40 °C to +85 °C

Key Features

- Switch selectable EN (enabled/disabled)
- Selectable mode (DEM/Forced CCM) (ISL85005DEMO1Z)
- Internal and external compensation options
- Frequency synchronization option (ISL85005DEMO1Z)
- Adjustable soft-start option (ISL85005ADEMO1Z)
- Small and compact design

Related Literature

- For a full list of related documents please visit our website - [ISL85005](#) and [ISL85005A](#) product pages

Ordering Information

PART NUMBER	DESCRIPTION
ISL85005DEMO1Z	Small form-factor demonstration board for ISL85005FRZ
ISL85005ADEMO1Z	Small form-factor demonstration board for ISL85005AFRZ

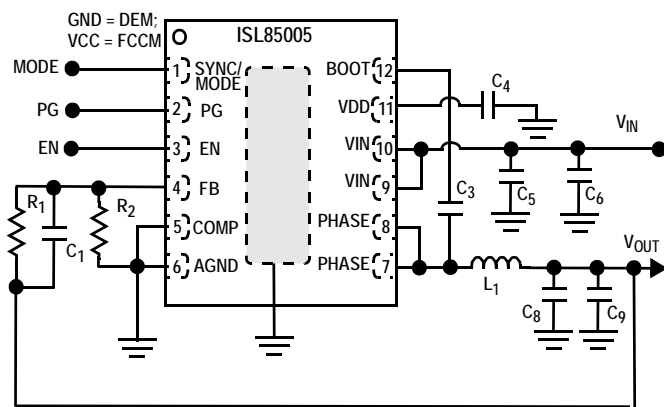

FIGURE 1A. ISL85005DEMO1Z

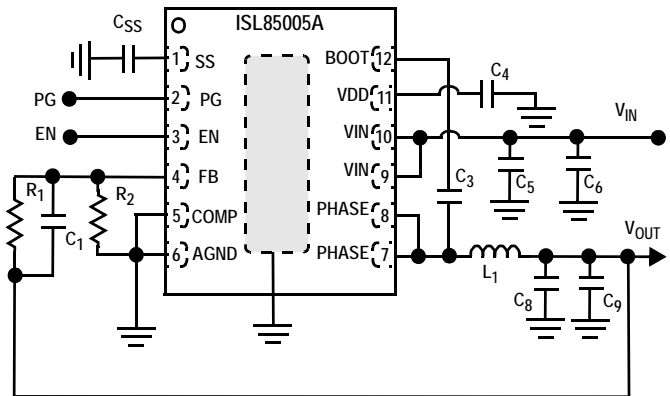

FIGURE 1B. ISL85005ADEMO1Z

FIGURE 1. BLOCK DIAGRAM

Connector and Selection Jumper Descriptions

The ISL85005DEMO1Z and ISL85005ADEMO1Z demonstration boards include I/O connectors and a selection jumper as shown in [Table 1](#).

TABLE 1. CONNECTORS AND JUMPER

REFERENCE DESIGNATOR	DESCRIPTION
J1	Selection Jumper for Enable (EN)
J3	Input voltage positive connection
J4	Input voltage return connection
J5	Output voltage positive connection
J6	Output voltage return connection

Quick Setup Guide

Refer to the following Quick Setup Guide to configure and power-up the board for proper operation.

1. Set the power supply voltage to 12V, and turn off the power supply. Connect the positive output of power supply to J3 (VIN) and the negative output to J4 (GND).
2. Connect an electronic load to J5 (VOUT) for the positive connection and J6 (GND) for the negative connection.
3. Measure the output voltage (J5 and J6) with the voltmeter.
4. Place scope probes on VOUT and other test points of interest.
5. Set EN jumper (J1) to ON position.
6. Set the load current to be 0.1A and turn on the power supply, the output voltage should be in regulation with a nominal 5V output.
7. Slowly increase the load up to 5A while monitoring the output voltage which should remain in regulation with a nominal 5V output.
8. Slowly sweep VIN from 7V to 15V, the output voltage should remain in regulation with a nominal 5V output.
9. Decrease the input voltage to 0V to shut down the regulator.

Operation Mode Selection (ISL85005DEMO1Z)

The ISL85005DEMO1Z can be configured in either forced Continuous Conduction Mode (CCM) or Diode Emulation Mode (DEM):

- In the default configuration of ISL85005DEMO1Z, SYNC/MODE (Pin 1) of ISL85005 is floating, the ISL85005 operates in forced CCM.
- To configure the ISL85005 in DEM, short the SYNC/MODE pin to GND by populating a 0Ω resistor for C_{SS}. DEM enables automatic transition from CCM to DCM and higher efficiency at light-load conditions.

Frequency Synchronization (ISL85005DEMO1Z)

The ISL85005 can be synchronized to an external clock with frequency ranges from 300kHz to 2MHz by applying the external clock to the SYNC/MODE pin on the ISL85005DEMO1Z demonstration board. The external clock should meet the specifications of the pulse width and voltage level described in the datasheet.

Adjusting Soft-Start Time (ISL85005ADEMO1Z)

With the SS pin floating, the ISL85005A features an internally set 2.3ms of soft-start time. The soft-start time can be set to a desired value by connecting an external capacitor (C_{SS} on the ISL85005ADEMO1Z demonstration board) between the SS pin and AGND. The capacitance can be calculated by [Equation 1](#):

$$C_{SS}[\text{nF}] = 3.5 \cdot t_{SS}[\text{ms}] - 1.6\text{nF} \quad (\text{EQ. 1})$$

Evaluating Other Output Voltages

Both ISL85005DEMO1Z and ISL85005ADEMO1Z have a nominal 5V output voltage. The output voltages are programmable by an external resistor divider formed by R₁ and R₂ as shown in [Figure 1 on page 1](#). R₁ is usually chosen first, then the value for R₂ can be calculated based on R₁ and the desired output voltage using [Equation 2](#).

$$R_2 = \frac{R_1 \cdot 0.8V}{V_{OUT} - 0.8V} \quad (\text{EQ. 2})$$

PCB Layout Considerations

The PCB layout is critical for proper operation of the ISL85005 and ISL85005A. The following guidelines should be followed to achieve good performance.

1. Use a multilayer PCB structure to achieve optimized performance, a four-layer PCB is recommended for this design.
2. Use a combination of bulk capacitors and smaller ceramic capacitors with lower ESL for the input capacitors and place them as close to the IC as possible.
3. Place the VDD decoupling capacitor close to the IC between VDD and GND. A 1μF ceramic capacitor is typically used.
4. Place a bootstrap capacitor close to the IC between the BOOT and PHASE pins. A 0.1μF ceramic capacitor is typically used.
5. Connect the feedback resistor divider between the output capacitor positive terminal and the AGND pin of the IC, and place the resistors close to the FB pin of the IC.
6. Connect the EPAD of the IC to the GND planes underneath using multiple thermal vias to improve thermal performance.

ISL85005xDEMO1Z Demonstration Board



FIGURE 2. TOP VIEW

Schematic

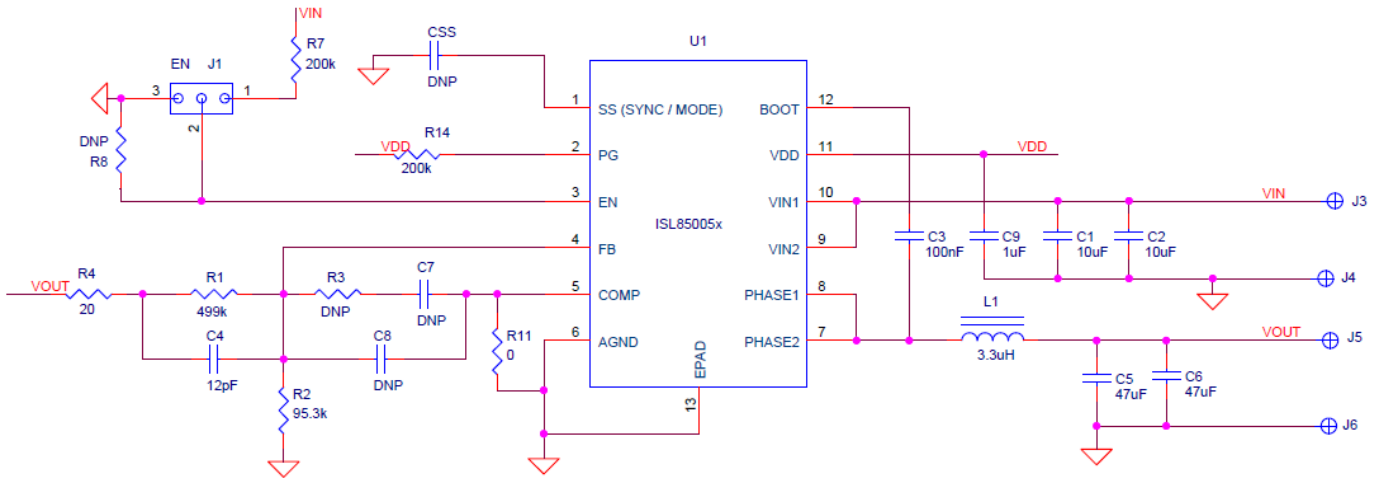

FIGURE 3. ISL85005xDEMO1Z SCHEMATIC

Bill of Materials

MANUFACTURER PART NUMBER	REFERENCE DESIGNATOR	QTY	DESCRIPTION	MANUFACTURER
ISL85005FRZ (ISL85005DEMO1Z)	U1	1	IC-BUCK REGULATOR W/ SYNC/MODE PIN, 12PIN, DFN, 3x4, ROHS	INTERSIL
ISL85005AFRZ (ISL85005ADEMO1Z)		1	IC-BUCK REGULATOR W/ SS PIN, 12PIN, DFN, 3x4, ROHS	INTERSIL
GRM1555C1H120JA01D	C4	1	CAP, SMD, 0402, 12pF, 50V, 5%, NP0, ROHS	MURATA
	C7, C8, C _{SS}	0	CAP, SMD, 0402, DNP-PLACE HOLDER, ROHS	
GRM188R71E104KA01D	C3	1	CAP, SMD, 0603, 0.1μF, 25V, 10%, X7R, ROHS	MURATA
GRM188R61E105KA12D	C9	1	CAP, SMD, 0603, 1μF, 25V, 10%, X5R, ROHS	MURATA
C1206X7R250-106KNE	C1, C2	2	CAP, SMD, 1206, 10μF, 25V, 10%, X7R, ROHS	VENKEL
CL32A476KOJNNNE	C5, C6	2	CAP, SMD, 1210, 47μF, 16V, 10%, X5R, ROHS	SAMSUNG
744314330	L1	1	COIL-PWR INDUCTOR, SMD, 6.9mm ² , 3.3μH, 9A 9mΩ, WW, ROHS	WURTH ELEKTRONIK
1514-2	J3, J4, J5, J6	4	CONN-TURRET, TERMINAL POST, TH, ROHS	KEYSTONE
ERJ2RKF20R0	R4	1	RES, SMD, 0402, 20Ω, 1/16W, 1%, TF, ROHS	PANASONIC
CR0402-16W-00T	R11	1	RES, SMD, 0402, 0Ω, 1/16W, 5%, TF, ROHS	VENKEL
MCR01MZPF2003	R7, R14	2	RES, SMD, 0402, 200k, 1/16W, 1%, TF, ROHS	ROHM
CR0402-16W-4993FT	R1	1	RES, SMD, 0402, 499k, 1/16W, 1%, TF, ROHS	VENKEL
RC0402FR-0795K3L	R2	1	RES, SMD, 0402, 95.3k, 1/16W, 1%, TF, ROHS	YAGEO
	R3, R8	0	RES, SMD, 0402, DNP, DNP, DNP, TF, ROHS	
929950-00	Jumper	1	CONN-JUMPER, SHORTING, 2PIN, BLK, OPEN TOP, 2.54mmPITCH, ROHS	3M
PEC03SAAN	J1	1	3 Positions Header, 100 mil (2.54mm) spacing, Through Hole Tin	Sullins Connector Solutions
ISL85005xDEMO1Z	PCB	1	PWB-PCB, ISL85005xDEMO1Z, REVA, ROHS	Any

ISL85005xDEMO1Z PCB Layout

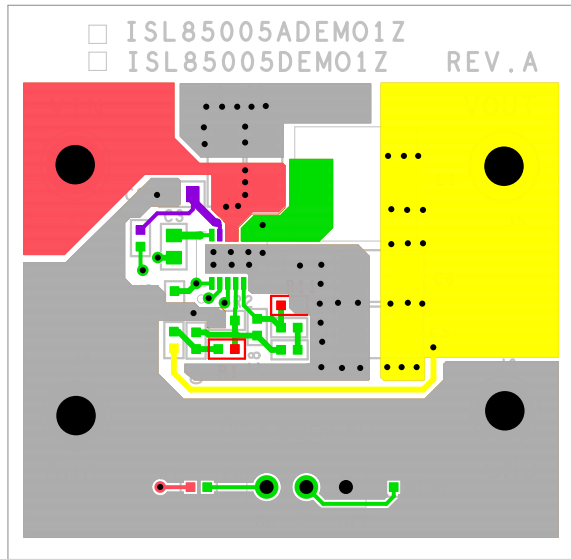

FIGURE 4. TOP LAYER

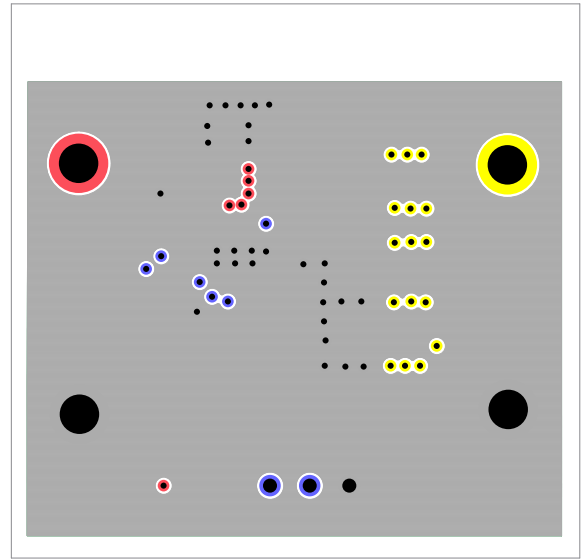

FIGURE 5. LAYER 2

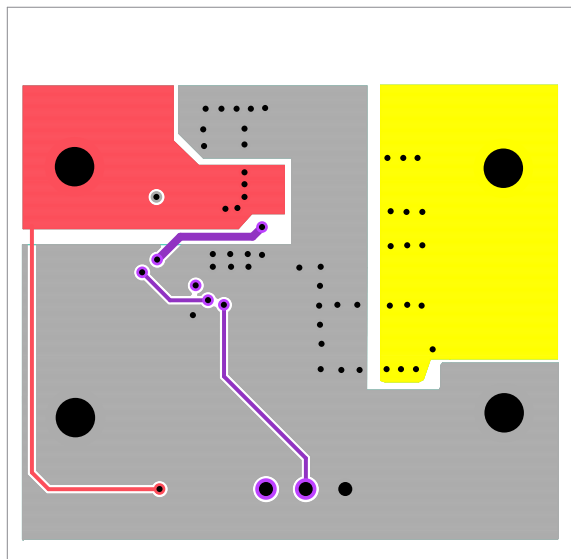

FIGURE 6. LAYER 3

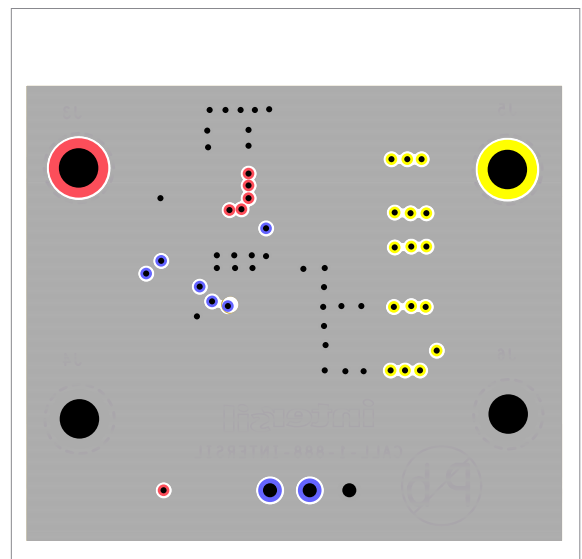

FIGURE 7. BOTTOM LAYER