

ISL8502AEVAL1Z

2A Synchronous Buck Regulator with Integrated MOSFETs

AN1703
Rev 0.00
October 21, 2011

The ISL8502A is a synchronous buck controller with internal MOSFETs packaged in a small 4mmx4mm QFN package. The ISL8502A can support a continuous load of 2A and has a very wide input voltage range. With the switching MOSFETs integrated into the IC, the complete regulator footprint can be very small and provide a much more efficient solution than a linear regulator.

The ISL8502A is capable of standalone operation or it can be used in a master slave combination for multiple outputs that are derived from the same input rail. Multiple slave channels can be individually programmed such that the internal clocks are out-of-phase. This method minimizes the ripple on the input rail.

The switching PWM controller drives two internal N-Channel MOSFETs in a synchronous-rectified buck converter topology. The synchronous buck converter uses voltage-mode control with fast transient response. The switching regulator provides a maximum static regulation tolerance of $\pm 1\%$ over line, load, and temperature ranges. The output is user-adjustable by means of external resistors down to 0.6V.

The output is monitored for undervoltage events. The switching regulator also has over current protection. Thermal shutdown is integrated. The ISL8502A features a bidirectional Enable pin that allows the part to shut itself down and pull the enable pin low at the same time. PG00D Rising Delay (measured from VOUT reaching regulation to PG00D Rising) has been reduced from 250ms (typical) for ISL8502 to 1ms (typical) for ISL8502A (measured at 500kHz switching frequency).

Pin Configuration

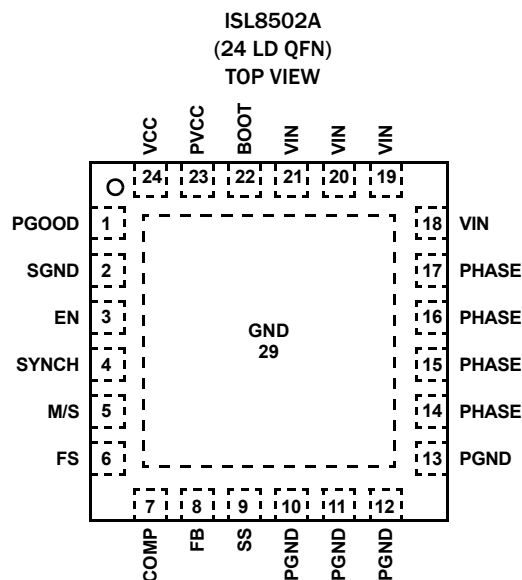

Features

- 2A Continuous Output Current
- Integrated MOSFETs for Small Regulator Footprint
- Adjustable Switching Frequency, 500kHz to 1.2MHz
- Tight Output Voltage Regulation, $\pm 1\%$ Over-Temperature
- Wide Input Voltage Range, 5V $\pm 10\%$ or 5.5V to 14V
- Wide Output Voltage Range, from 0.6V
- Simple Single-Loop Voltage-Mode PWM Control Design
- Input Voltage Feed-Forward for Constant Modulator Gain
- Fast PWM Converter Transient Response
- Lossless $r_{DS(ON)}$ High Side and Low Side Overcurrent Protection
- Undervoltage Detection
- Integrated Thermal Shutdown Protection
- Power-Good Indication
- Adjustable Soft-Start
- QFN Package
 - Compliant to JEDEC PUB95 MO-220 QFN (Quad Flat No Leads) package outline
 - Near Chip Scale Package footprint, which improves PCB efficiency and has a thinner profile
- Pb-Free (RoHS Compliant)

Applications

- Point of Load Applications
- Graphics Cards - GPU and Memory Supplies
- ASIC Power Supplies
- Embedded Processor and I/O Supplies
- DSP Supplies

Ordering Information

PART NUMBER	PART MARKING	TEMP. RANGE (°C)	PACKAGE (Pb-free)	PKG. DWG. #
ISL8502AIRZ (Notes 1, 2, 3)	85 02AIRZ	-40 to +85	24 Ld 4x4 QFN	L24.4x4D
ISL8502AEVAL1Z	Evaluation Board			

NOTES:

1. Add "-T*" suffix for tape and reel. Please refer to [TB347](#) for details on reel specifications.
2. These Intersil Pb-free plastic packaged products employ special Pb-free material sets, molding compounds/die attach materials, and 100% matte tin plate plus anneal (e3 termination finish, which is RoHS compliant and compatible with both SnPb and Pb-free soldering operations). Intersil Pb-free products are MSL classified at Pb-free peak reflow temperatures that meet or exceed the Pb-free requirements of IPC/JEDEC J STD-020.
3. For Moisture Sensitivity Level (MSL), please see device information page for [ISL8502A](#). For more information on MSL please see tech brief [TB363](#).

What's Inside

The Evaluation Board Kit contains the following materials:

- The ISL8502A EVAL REVD board
- The ISL8502A datasheet
- This EVAL KIT document

Recommended Equipment

The following materials are recommended to perform testing:

- 0V to 15V power supply with at least 5A source current capability, battery, notebook AC adapter
- Two Electronic Loads capable of sinking current up to 5A
- Digital Multimeters (DMMs)
- 100MHz quad-trace Oscilloscope
- Signal generator (only if the SYNC function needs to be evaluated)

Quick Setup Guide

1. Ensure that the circuit is correctly connected to the supply and loads prior to applying any power.
2. Connect the bias supply to VIN. Plus terminal to J1(VIN) and negative return to J2(GND).
3. Verify that all positions are ON for S1, EN_all, EN_1, EN_2.
4. Turn on the power supply.
5. Verify the outputs voltages are 2.5V for V_{OUT1} and V_{OUT2}.

Evaluating Other Output Voltages

The ISL8502AEVAL kit outputs are preset to 2.5V. For a quick evaluation of output voltages between 0.6V and V_{IN} -1.7V, the following resistors need to be changed in the feedback network as shown in Equations 1 and 2:

$$R_{111} = (R_{108}) / [(V_{OUT} / V_{FB1})^{-1}] \quad (\text{EQ. 1})$$

where R₁₀₈ = 17.4kΩ; and V_{FB1} = 0.6V

$$R_{211} = (R_{208}) / [(V_{OUT2} / V_{FB2})^{-1}] \quad (\text{EQ. 2})$$

where R₂₀₈ = 17.4kΩ; and V_{FB2} = 0.6V

However, for reliable operation over the entire load and temperature range, it is highly recommended to follow the output filter and loop compensation network design guidelines as listed in the ISL8502A datasheet.

Frequency

The ISL8502AEVAL can operate at switching frequencies from 500kHz to 1.2MHz. R₁₀₄ and R₂₀₄ are used to program the switching frequency through Equation 3:

$$R_{104} \text{ and } (R_{204}) = 48000 / (f_{osc} [\text{kHz}]) \quad (\text{EQ. 3})$$

TABLE 1. SWITCH 1 SETTINGS

SW1	SKIP	OPERATING MODE
1	NC	No Connect
2	EN_ALL	Enable or disable V _{OUT1} and V _{OUT2}
3	EN1	Enable or disable V _{OUT1}
4	EN2	Enable or disable V _{OUT2}

Soft-start

C107, C207 can be used to adjust the soft-start time.

ISL8502AEVAL1Z Schematic

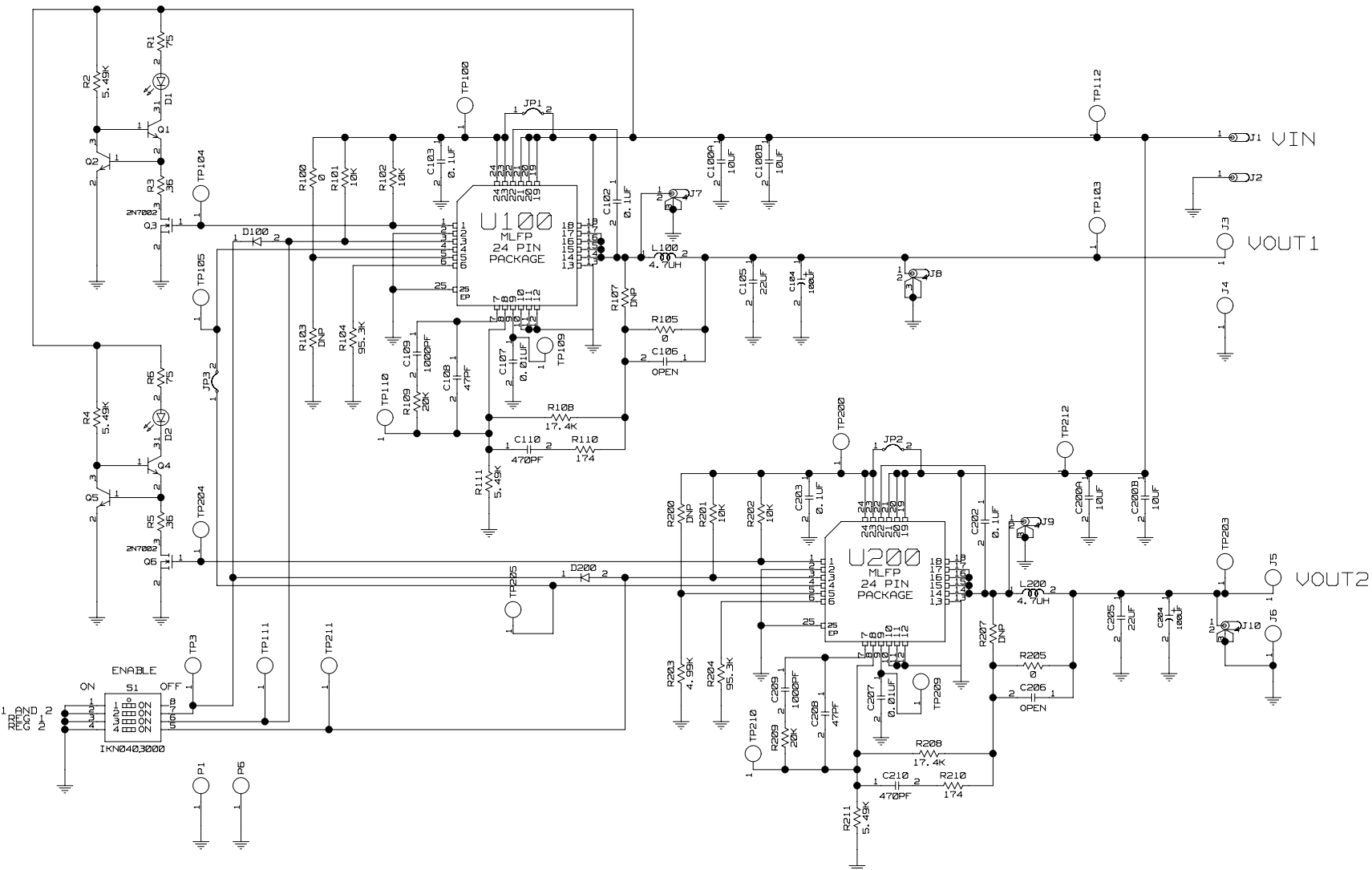

TABLE 2. BILL OF MATERIALS

PART NUMBER	QTY	UNITS	REFERENCE DESIGNATOR	DESCRIPTION	MANUFACTURER	MANUFACTURER PART
ISL8502EVAL1ZREVEPCB	1	ea	SEE LABEL- RENAME BOARD	PWB-PCB, ISL8502EVAL1Z, REV E, SOIC, ROHS	IMAGINEERING INC	ISL8502EVAL1ZREVEPCB
GRM21BR71C475KA73L	2	ea	C111, C211	CAP, SMD, 0805, 4.7µF, 16V, 10%, X7R, ROHS	MURATA	GRM21BR71C475KA73L
H1044-00104-16V10-T	2	ea	C102, C202	CAP, SMD, 0402, 0.1µF, 16V, 10%, X7R, ROHS	VENKEL	C0402X7R160-104KNE
					MURATA	GRM155R71C104KA88D
					PANASONIC	ECJ-0EX1C104K
					TAIYO YUDEN	EMK105B7104KV-F
					YAGEO	CC0402KRX7R7BB104
					KEMET	C0402C104K4RACTU
					TDK	C1005X7R1C104K
H1044-00105-10V10-T	2	ea	C103, C203	CAP, SMD, 0402, 1.0µF, 10V, 10%, X5R, ROHS	MURATA	GRM155R61A105KE15D
					VENKEL	C0402X5R100-105KNE
					TAIYO YUDEN	LMK105BJ105KV-F
					AVX	0402ZD105KAT2A
H1044-00150-50V5-T	2	ea	C108, C208	CAP, SMD, 0402, 15pF, 50V, 5%, NP0, ROHS	MURATA	GRM36COG150J050AQ
					PANASONIC	ECU-E1H150JCQ
					VENKEL	C0402COG500-150JNE
H1044-00153-16V10-T	2	ea	C107, C207	CAP, SMD, 0402, 0.015µF, 16V, 10%, X7R, ROHS	PANASONIC	ECJ-0EB1C153K
					VENKEL	C0402X7R160-153KNE
					AVX	0402YC153KAT2A
					MURATA	GRM155R71C153KA01D
H1044-00471-50V10-T	2	ea	C110, C210	CAP, SMD, 0402, 470pF, 50V, 10%, X7R, ROHS	PANASONIC	ECJ-0EB1H471K
					VENKEL	C0402X74500-471KNE
H1044-00821-50V10-T	2	ea	C109, C209	CAP, SMD, 0402, 820pF, 50V, 10%, X7R, ROHS	PANASONIC	ECJ-0EB1H821K
H1044-DNP	0	ea	C106, C206	CAP, SMD, 0402, DNP- PLACE HOLDER, ROHS		
H1046-DNP	0	ea	C112, C113	CAP, SMD, 0805, DNP- PLACE HOLDER, ROHS		
H1065-00106-25V10-T	4	ea	C100A, C100B, C200A, C200B	CAP, SMD, 1206, 10µF, 25V, 10%, X5R, ROHS	VENKEL	C1206X5R250-106KNE
H1082-00107-10V20-T	2	ea	C105, C205	CAP, SMD, 1210, 100µF, 10V, 20%, X5R, ROHS	TAIYO YUDEN	LMK325BJ107MM-T
111-0702-001	1	ea	VIN	CONN-GEN, BIND.POST, INSUL-RED, THMBNUT- GND	JOHNSON COMPONENTS	111-0702-001
					KEYSTONE	7006
111-0703-001	1	ea	GND	CONN-GEN, BIND.POST, INSUL-BLK, THMBNUT- GND	JOHNSON COMPONENTS	111-0703-001
					KEYSTONE	7007
131-4353-00	4	ea	J7-J10	CONN-SCOPE PROBE TEST PT, COMPACT, PCB MNT, ROHS	TEKTRONIX	131-4353-00
1514-2	6	ea	J3-J6, P1, P2	CONN-TURRET, TERMINAL POST, TH, ROHS	KEYSTONE	1514-2

TABLE 2. BILL OF MATERIALS (Continued)

PART NUMBER	QTY	UNITS	REFERENCE DESIGNATOR	DESCRIPTION	MANUFACTURER	MANUFACTURER PART
5002	17	ea	a) TP3, TP100, TP103-TP105, TP109-TP112,	CONN-MINI TEST POINT, VERTICAL, WHITE, ROHS	KEYSTONE	5002
5002	0	ea	b) TP200, TP203-TP205, TP209-TP212	CONN-MINI TEST POINT, VERTICAL, WHITE, ROHS	KEYSTONE	5002
69190-202HLF	3	ea	JP1-JP3	CONN-HEADER, 1X2, RETENTIVE, 2.54mm, 0.230X 0.120, ROHS"	BERG/FCI	69190-202HLF
SPC02SYAN	1	ea	JP3	CONN-JUMPER, SHORTING, 2 PIN, BLACK, GOLD, ROHS	SULLINS	SPC02SYAN
1N4148WS-7-F-T	2	ea	D100, D200	DIODE-RECTIFIER, SMD, SOD-323, 2P, 75V, 150mA, ROHS	DIODES INC.	1N4148WS-7-F
BAT54-T	0	ea	DNP (D1, D3)	DIODE-SCHOTTKY, SMD, SOT23, 3P, 30V, 200mA, SINGLE DIODE	FAIRCHILD	BAT54
PDS560-13	0	ea	DNP (D2, D4)	DIODE-RECTIFIER, SMD, POWER DI5, 3P, 60V, 5A, ROHS	DIODES INC.	PDS560-13
LTST-C170CKT	2	ea	LED1, LED2	LED-GaAs RED, SMD, 2mmx1.25mm, 100mW, 40mA, 10mcd, ROHS	LITEON/VISHAY	LTST-C170CKT
					ROHM	SML-210LTT86
					STANLEY ELECTRIC	BR112H-TR
CDRH8D28NP-4R7NC	2	ea	L100, L200	COIL-PWR INDUCTOR, SMD, 8.3mm, 4.7 μ H, 30%, 3.4A, ROHS, SHIELDED	SUMIDA ELECTRIC, CO.	CDRH8D28NP-4R7NC
ISL8502AIRZ	2	ea	U100, U200	IC-2A BUCK REGULATOR, 24P, QFN, 4X4, ROHS	INTERSIL	ISL8502AIRZ
2N7002-7-F-T	2	ea	Q3, Q6	TRANSISTOR, N-CHANNEL, 3 LD, SOT-23, 60V, 115mA, ROHS	DIODES, INC.	2N7002-7-F
					ON SEMICONDUCTOR	2N7002LT1G
MMBT2222ALT1G-T	4	ea	Q1, Q2, Q4, Q5	TRANSISTOR, NPN, 3 LD, SOT23, 40V, 600mA, ROHS		
H2510-00360-1/16W5-T	2	ea	R3, R5	RES, SMD, 0402, 36 Ω , 1/16W, 5%, TF, ROHS	YAGEO	RC0402JR-0736RL
					VENKEL	CR0402-16W-360JT
H2510-00750-1/16W5-T	2	ea	R1, R6	RES, SMD, 0402, 75 Ω , 1/16W, 5%, TF, ROHS	PANASONIC	ERJ2GEJ0750
					VENKEL	CR0402-16W-750JT
H2510-00R00-1/16W-T	3	ea	R100, R105, R205	RES, SMD, 0402, 0 Ω , 1/16W, 5%, TF, ROHS	VENKEL	CR0402-16W-00T
					PANASONIC	ERJ-2GE0JR00
H2510-01002-1/16W1-T	4	ea	R101, R102, R201, R202	RES, SMD, 0402, 10k, 1/16W, 1%, TF, ROHS	PANASONIC	ERJ-2RKF1002X
					VENKEL	CR0402-16W-1002FT
					ROHM	MCR01MZPF1002
					YAGEO	RC0402FR-0710KLL
					VISHAY/DALE	CRCW040210K0FKED

TABLE 2. BILL OF MATERIALS (Continued)

PART NUMBER	QTY	UNITS	REFERENCE DESIGNATOR	DESCRIPTION	MANUFACTURER	MANUFACTURER PART
H2510-01401-1/16W1-T	2	ea	R110, R210	RES, SMD, 0402, 1.4k, 1/16W,1%, TF, ROHS	VISHAY/DALE	CRCW04021K40FKED
					STACKPOLE	RMCF0402FT1K40
					VENKEL	CR0402-16W-1401FT
H2510-02802-1/16W1-T	4	ea	R108, R109, R208, R209	RES, SMD, 0402, 28k,1/16W, 1%, TF, ROHS	VENKEL	CR0402-16W-2802FT
					PANASONIC	ERJ-2RKF2802X
					ROHM	MCR01MZPF2802
					YAGEO	RC0402FR-0728KL
					VISHAY/DALE	CRCW040228K0FKED
H2510-04991-1/16W1-T	1	ea	R203	RES, SMD, 0402, 4.99k, 1/16W, 1%, TF, ROHS	KDA	RK73H1E4991F
					VENKEL	CR0402-16W-4991FT
H2510-05491-1/16W1-T	2	ea	R2, R4	RES, SMD, 0402, 5.49k, 1/16W, 1%, TF, ROHS		
H2510-06041-1/10W1-T	2	ea	R111, R211	RES, SMD, 0402, 6.04k, 1/10W, 1%, TF, ROHS	PANASONIC	ERJ2RKF6041X
H2510-09532-1/16W1-T	2	ea	R104, R204	RES, SMD, 0402, 95.3k, 1/16W, 1%, TF, ROHS	YAGEO	RC0402FR-0795K3L
					VENKEL	CR0402-16W-9532FT
H2510-DNP	0	ea	R103, R107, R200, R207	RES, SMD, 0402, DNP, DNP, TF, ROHS		
H2511-00100-1/10W1-T	2	ea	R112, R212	RES, SMD, 0603, 10Ω, 1/10W, 1%, TF, ROHS	KOA	RK73H1JT10R0F
					VENKEL	CR0603-10W-10R0FT
H2515-DNP	0	ea	R113, R114	RES, SMD, 2512, DNP, DNP, TF, ROHS		
IKN0403000	1	ea	S1 (Install according to silkscreen)	SWITCH-DIP, SMD, 4P, SLIDE, SPST, LP, ROHS	APEM	IKN0403000
4-40X1/2-SCREW	4	ea	Four corners	SCREW, 4-40X1/2in, PAN, NYLON, PHILLIPS, ROHS		
4-40X3/4-STANDOFF	4	ea	Four corners	STANDOFF, 4-40X3/4in, F/F, HEX, NYLON, ROHS	KEYSTONE	1902D
5X8-STATIC-BAG	1	ea	Place assy in bag	BAG, STATIC, 5X8, ZIPLOC, ROHS	INTERSIL	212403-013
DNP	0	ea	C104, C204	DO NOT POPULATE OR PURCHASE		
LABEL-DATE CODE	1	ea		LABEL-FOR DATE CODE AND BOM REV #	INTERSIL	LABEL-DATE CODE
LABEL-RENAME BOARD	1	ea	RENAME PCB TO: ISL8502AEVAL1Z	LABEL, TO RENAME BOARD	INTERSIL	LABEL-RENAME BOARD

ISL8502AEVAL1Z Board Layout

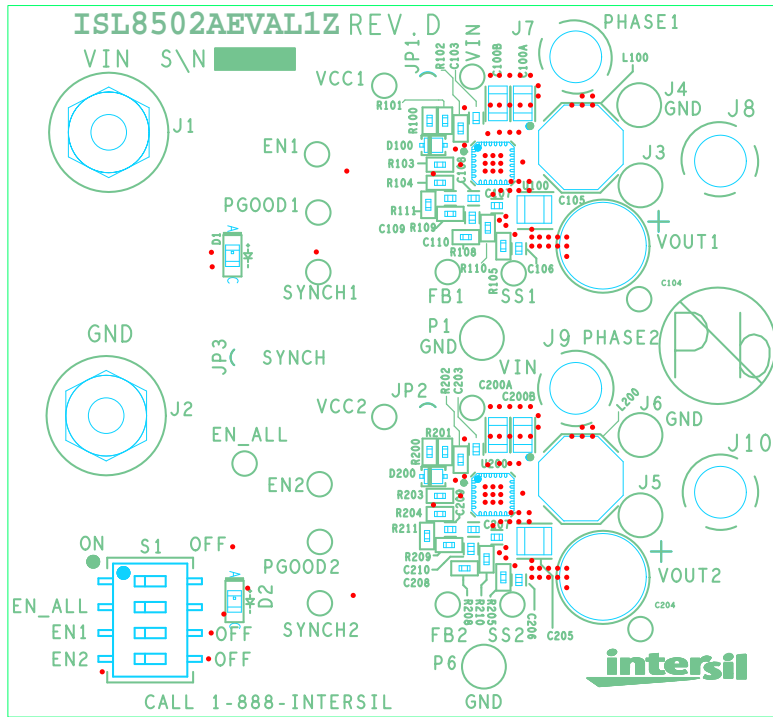

FIGURE 1. TOP COMPONENTS

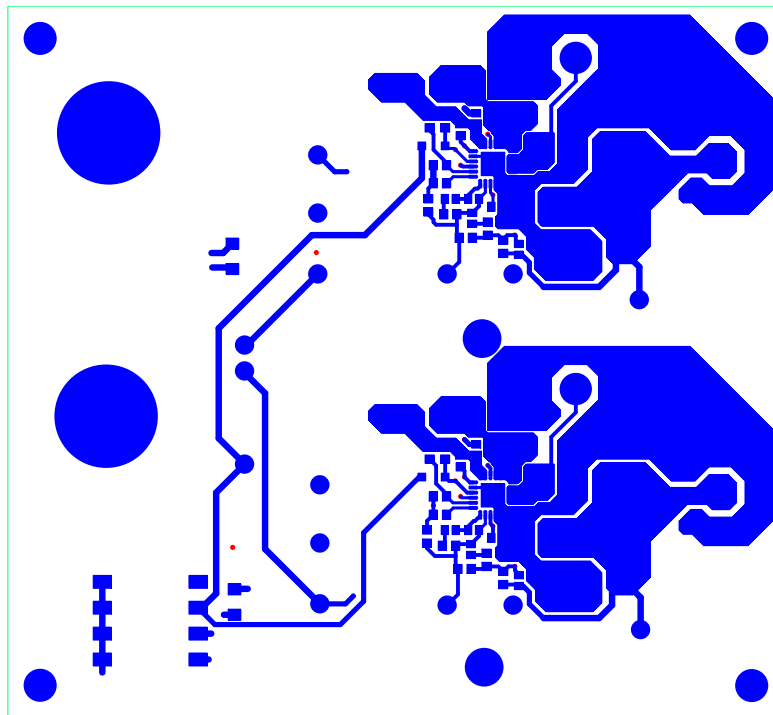

FIGURE 2. TOP LAYER ETCH

ISL8502AEVAL1Z Board Layout (Continued)

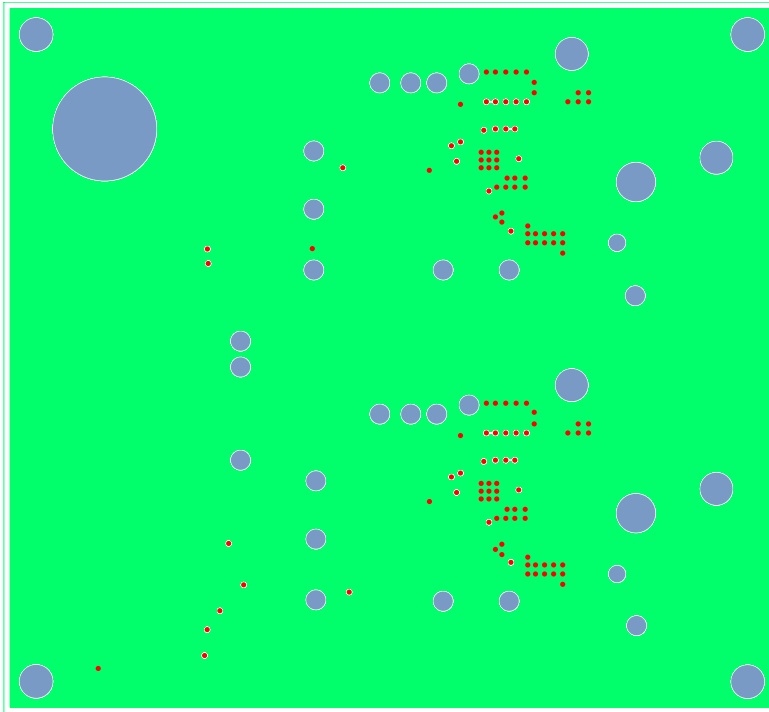

FIGURE 3. 2ND LAYER ETCH

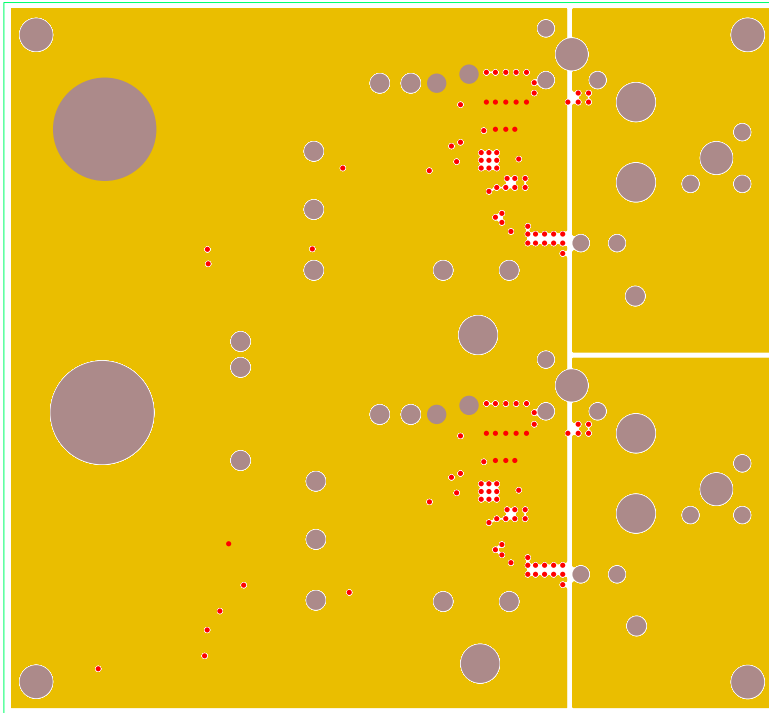

FIGURE 4. 3RD LAYER ETCH

ISL8502AEVAL1Z Board Layout (Continued)

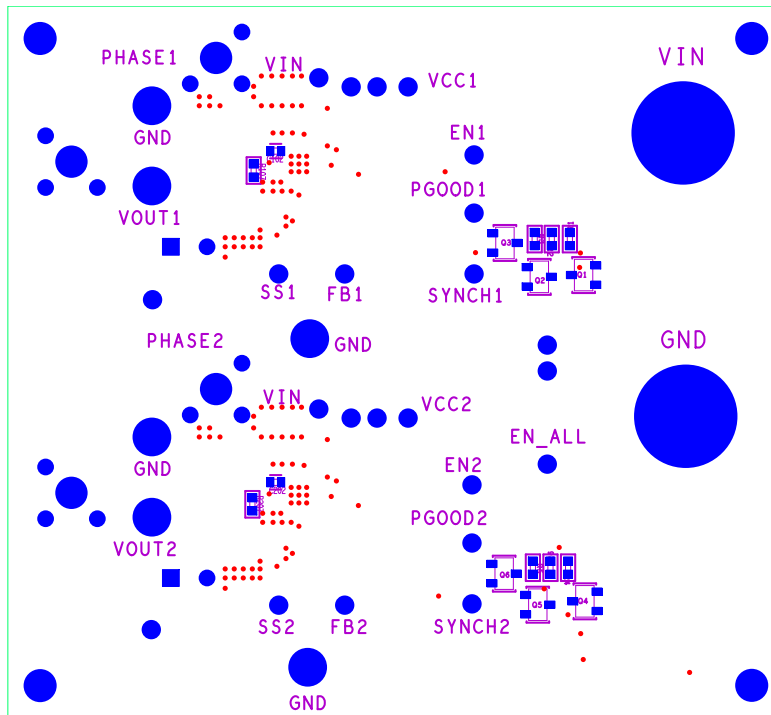

FIGURE 5. BOTTOM LAYER COMPONENTS (MIRRORED)

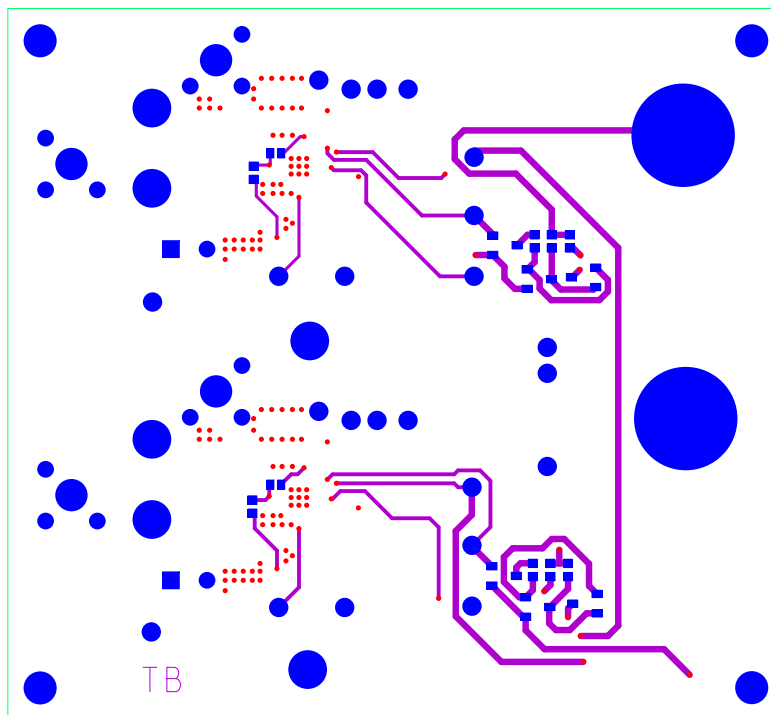

FIGURE 6. BOTTOM LAYER ETCH (MIRRORED)