

ISL85033EVAL2Z

(Small Form) Wide VIN Dual Standard Buck Regulator With 3A/3A Output Current - Short Form

AN1585
Rev 1.00
Nov 29, 2010

Description

The ISL85033EVAL2Z kit demonstrates performance of the ISL85033 switching regulator IC. An input range of 4.5V to 28V and 3A output per channel (connect in parallel to 6A) allows the ISL85033 to meet a wide variety of POL requirements.

The ISL85033 is offered in a 4mmx4mm 28 Ld TQFN package with 1mm maximum height. The complete converter occupies 6.25cm² area.

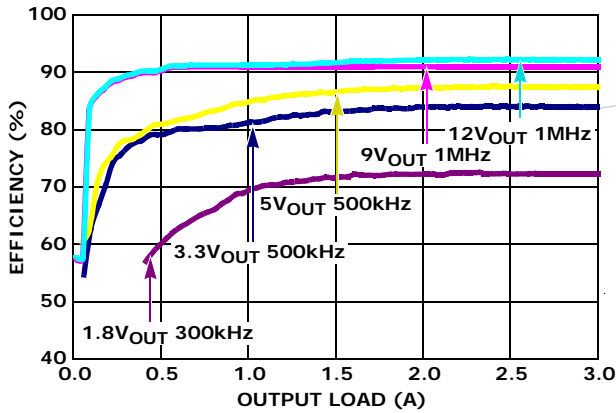

FIGURE 1. EFFICIENCY vs LOAD, T_A = +25°C, V_{IN} = 28V

Key Features

- Wide Input Voltage Range from 4.5V to 28V
- Adjustable Output Voltage with Continuous Output Current up to 3A per channel
- Current Mode Control
- Adjustable Switching Frequency from 300kHz to 2MHz
- Independent Power-Good Detection
- Selectable In-Phase or Out-of-Phase PWMs Switching Operation
- Independent, Sequential, Ratiometric or Absolute Tracking Between Outputs
- Internal 2ms Soft-start Time
- Overcurrent and Hiccup Mode Short Circuit Protection, Thermal Overload Protection, UVLO
- Boot Undervoltage Detection
- Channels are Out-of-phase, Reducing Voltage Ripple and Component Size

Quick Setup Guide

1. Ensure correct board connection to the supply ("+" to VIN1 and "-" to GND2) and loads prior to applying power, then turn on the power supply.
2. Verify the output voltage is 5V for V_{OUT1} and 3.3V for V_{OUT2}.

Frequency Control

ISL85033 has an FS pin that controls the frequency of operation. Programmable frequency allows for optimization between efficiency and external component size. ISL85033EVAL2Z has the switching frequency set to 500kHz (FS is tied to VCC).

SYNC Control

The ISL85033 has a SI pin for external synchronization. Default board configuration has R8 = 0 to GND, which defaults to the internally selected switching frequency. Removing R8 allows the synchronization to be external between 600kHz to 4MHz. Do not leave this pin floating.

Output Voltage Selection

ISL85033EVAL2Z board has V_{OUT1} set to 5V and V_{OUT2} set to 3.3V. The output voltage programming resistor, R₃ (R₁₀ respectively), will depend on the value chosen for the feedback resistor, R₂ (R₁₂ respectively), and the desired output voltage, V_{OUT}, see Equation 1. The value for R₂ (R₁₂ respectively) is typically between 1k and 10k.

$$R_3 = (V_{OUT1} - V_{FB}) \cdot R_2 / 0.8 \tag{EQ. 1}$$

$$R_{10} = (V_{OUT2} - V_{FB}) \cdot R_{12} / 0.8$$

Please note that if V_{OUT} is less than 2.5V, switching frequency and compensation must be changed for 300kHz operation due to minimum on-time limitation. Please refer to data sheet [FN6676](#) for further information.

ISL85033EVAL2Z REV. A

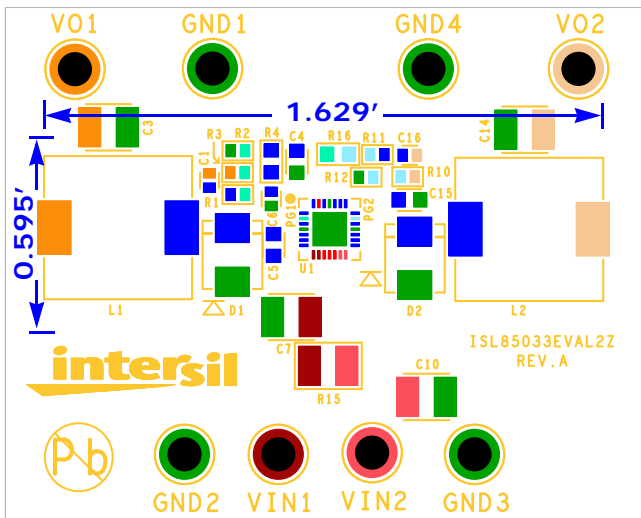

FIGURE 2. ISL85033EVAL2Z TOP LAYER COMPONENTS

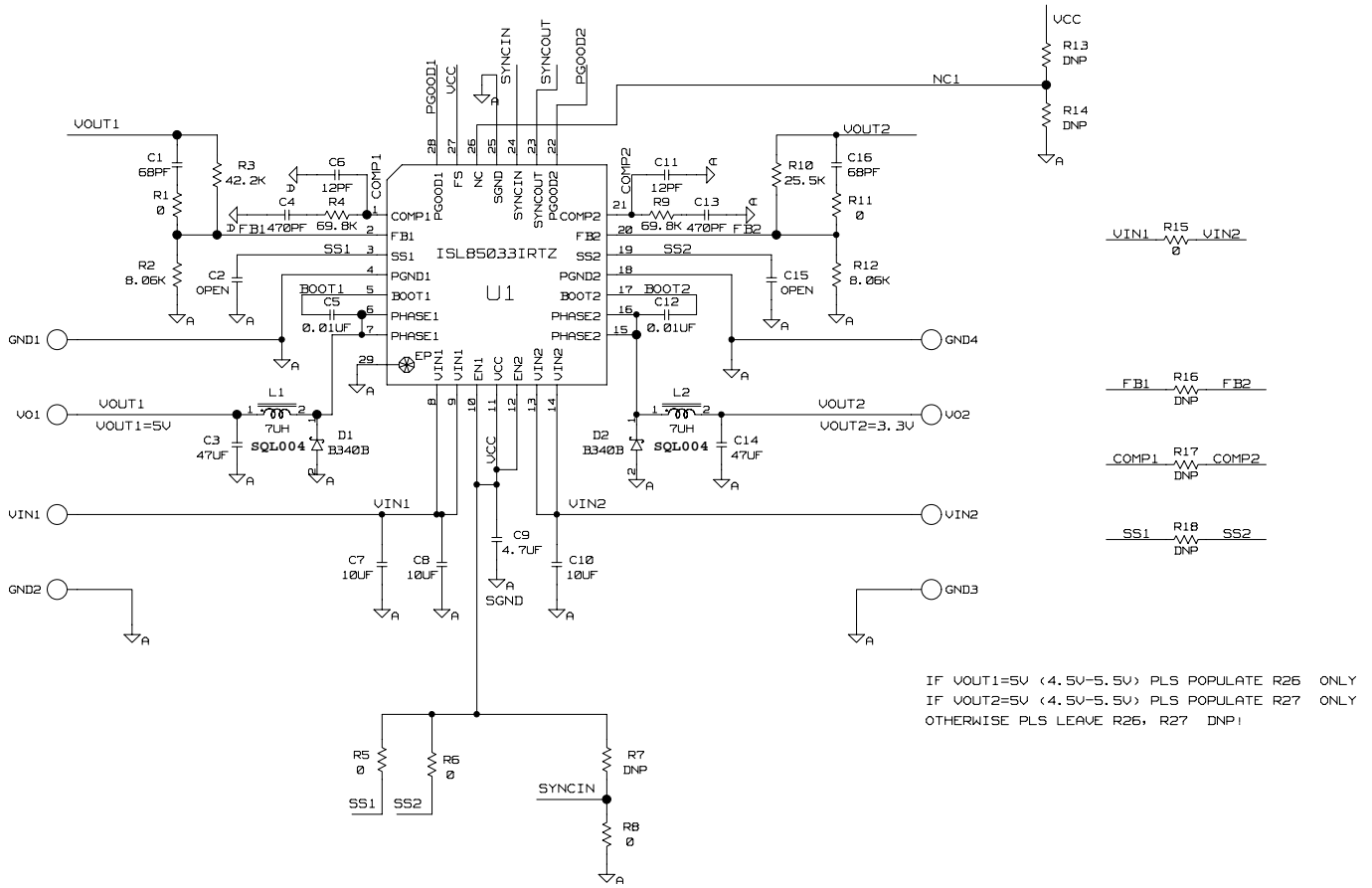

FIGURE 3. ISL85033EVAL2Z SCHEMATIC

ISL85033EVAL2Z REV.A

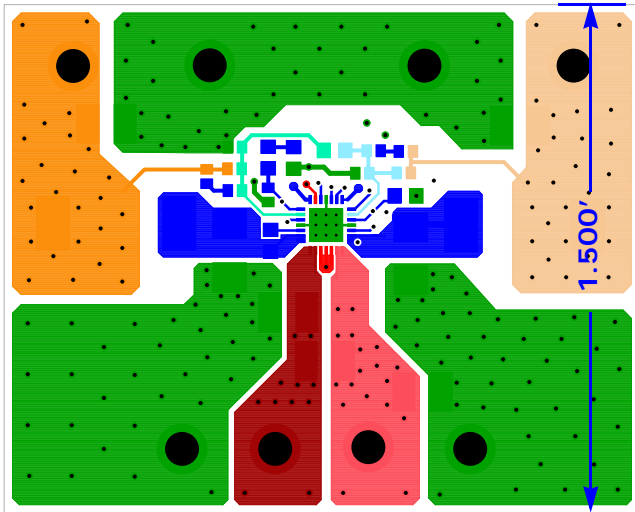

FIGURE 4. ISL85033EVAL2Z TOP LAYER ETCH

ISL85033EVAL2Z REV.A

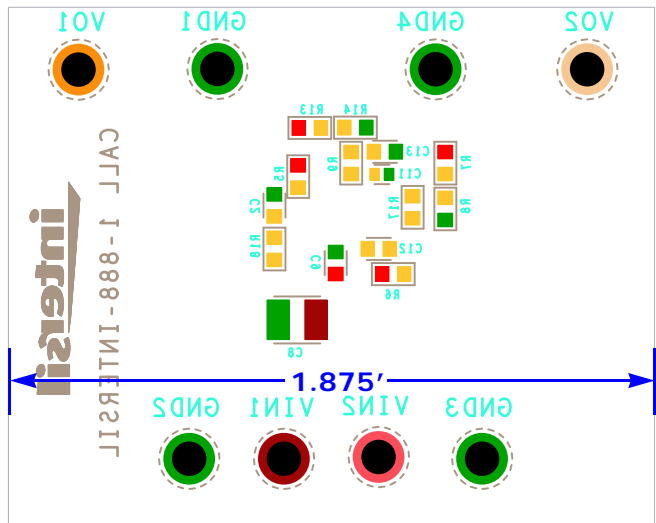

FIGURE 5. ISL85033EVAL2Z BOTTOM LAYER COMPONENTS