

Description

The ISL85410EVAL1Z, ISL854102EVAL1Z, and ISL85418EVAL1Z boards are intended for use for point-of-load applications sourcing from 3V to 40V. The boards are used to evaluate the performance of the [ISL85410](#), [ISL854102](#), and [ISL85418](#) wide V_{IN} low quiescent current high-efficiency synchronous buck regulators with 1A (ISL85410), 1.2A (ISL854102) and 800mA (ISL85418EVAL1Z) output current.

The ISL85410, ISL854102, and ISL85418 are offered in a 4mmx3mm 12 Ld DFN package with 1mm maximum height. The converter occupies 1.516cm² area.

Specifications

These boards have been configured and optimized for the following operating conditions:

- V_{IN} = 24V
- V_{OUT} = 3.3V
- I_{MAX} = 1A (ISL85410), 1.2A (ISL854102), and 800mA (ISL85418)
- f_{SW} = 500kHz
- Peak efficiency: >84% at 50% load
- Output ripple: <3mV at 1.2A
- Dynamic response: 4.5% (0A to 1.2A and 1.2A to 0A steps, PWM, $di/dt = 1A/\mu s$)
- Board temperature: +25°C

Key Features

- Wide input voltage range 3V to 40V
- Synchronous operation for high efficiency
- No compensation required
- Integrated high-side and low-side NMOS devices
- Selectable PFM or forced PWM mode at light loads
- Internal fixed (500kHz) or adjustable switching frequency 300kHz to 2MHz
- Continuous output current up to 1A (ISL85410), 1.2A (ISL854102), and 800mA (ISL85418)
- Internal or external soft-start
- Minimal external components required
- Power-good and enable functions available

Related Literature

- For a full list of related documents please visit our website - [ISL85410](#), [ISL85418](#), [ISL854102](#), product pages

Ordering Information

PART NUMBER	DESCRIPTION
ISL85410EVAL1Z	Evaluation board (1A output current)
ISL85418EVAL1Z	Evaluation board (800mA output current)
ISL854102EVAL1Z	Evaluation board (1.2A output current)

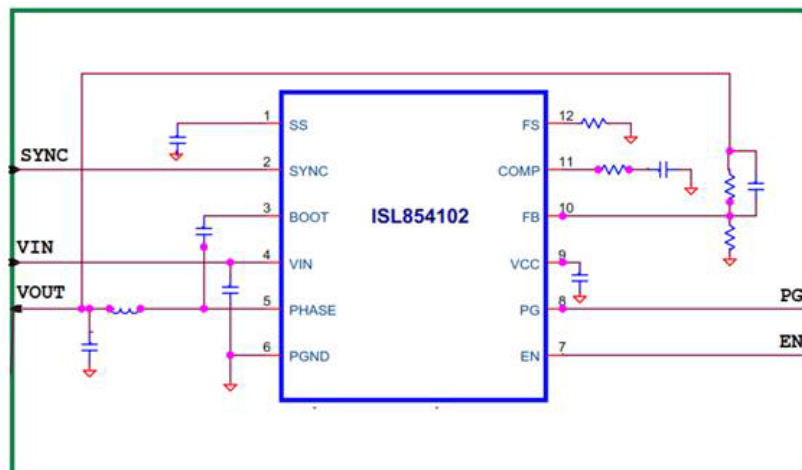

FIGURE 1. BLOCK DIAGRAM

Recommended Equipment

The following materials are recommended to perform testing:

- 0V to 50V power supply with at least 2A source current capability
- Electronic loads capable of sinking current up to 2A
- Digital Multimeters (DMMs)
- 100MHz quad-trace oscilloscope
- Signal generator

Quick Setup Guide

1. Ensure that the circuit is correctly connected to the supply and loads prior to applying any power.
2. Connect the bias supply to VIN, the plus terminal to VIN (P4), and the negative return to GND (P5).
3. Verify that the position is ON for S1.
4. Turn on the power supply.
5. Verify the output voltage is 3.3V for V_{OUT}.

Evaluating the Other Output Voltage

The ISL85410EVAL1Z, ISL854102EVAL1Z and ISL85418EVAL1Z board outputs are preset to 3.3V; however, output voltages can be adjusted from 0.6V to 15V. The output voltage programming resistor, R₂, will depend on the desired output voltage of the regulator and the value of the feedback resistor R₁, as shown in [Equation 1](#).

$$R_2 = R_1 \left(\frac{0.6}{V_{OUT} - 0.6} \right) \quad (\text{EQ. 1})$$

If the output voltage desired is 0.6V, then R₁ is shorted. Please note that if V_{OUT} is less than 1.8V, the switching frequency and compensation must be changed for 300kHz operation due to minimum on-time limitation. Please refer to datasheets [ISL85410](#), [ISL854102](#), and [ISL85418](#) for further information.

[Table 1](#) shows the component selection that should be used for the respective V_{OUT}.

TABLE 1. EXTERNAL COMPONENT SELECTION

V _{OUT} (V)	L ₁ (μH)	C ₅ +C ₆ (μF)	R ₁ (kΩ)	R ₂ (kΩ)	C ₄ (pF)	R ₁₂ (kΩ)	R ₃ (kΩ)	C ₇ (pF)
12	22	2x22	90.9	4.75	22	115	150	470
5	22	47+22	90.9	12.4	27	DNP (Note 1)	100	470
3.3	22	47+22	90.9	20	27	DNP (Note 1)	100	470
2.5	22	47+22	90.9	28.7	27	DNP (Note 1)	100	470
1.8	12	47+22	90.9	45.5	27	DNP (Note 1)	70	470

NOTE:

1. Connect FS to V_{CC}.

Frequency Control

The ISL85410, ISL854102, and ISL85418 have an FS pin that controls the frequency of operation. Programmable frequency allows for optimization between efficiency and external component size. It also allows low frequency operation for low V_{OUTs} when minimum on-time would limit the operation otherwise. Default switching frequency is 500kHz when FS is tied to V_{CC} (R₁₀ = 0). By removing R₁₀, the switching frequency could be changed from 300kHz (R₁₂ = 340k) to 2MHz (R₁₂ = 32.4k). Please refer to datasheets [ISL85410](#), [ISL854102](#), and [ISL85418](#) for calculating the value of R₁₀. Do not leave this pin floating.

Disabling/Enabling Function

The ISL85410, ISL85418 evaluation boards contain an S1 switch that enables or disables the part, thus allowing low quiescent current state. [Table 2](#) details this function.

TABLE 2. SWITCH SETTINGS

S1	ON/OFF CONTROL
ON	Enable V _{OUT}
OFF	Disable V _{OUT}

SYNC Control

The ISL85410, ISL85418 evaluation boards have a SYNC pin that allows external synchronization frequency to be applied. Default board configuration has R₆ = 200k to V_{CC}, which defaults to PWM operation mode and also to the preselected switching frequency set by R₁₂ (see datasheets and previous section [“Frequency Control”](#) for details). If this pin is tied to GND the IC will operate in PFM mode. The S2 switch allows forced PFM or PWM modes.

Soft-Start/COMP Control

R₁₅ selects between internal (R₁₅ = 0) and external soft-start. R₁₁ selects between internal (R₁₁ = 0) and external compensation. For applications where repetitive restarts of the IC are required, it is recommended to add a 350kΩ resistor in parallel to CSS in order to allow its fast discharge. Please refer to the pin description table of the [ISL85410](#), [ISL854102](#), and [ISL85418](#) datasheets.

Pictures of Boards

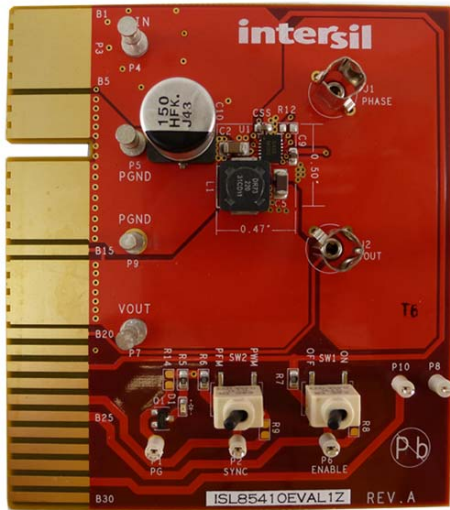

FIGURE 2. FRONT OF EVALUATION BOARD ISL85410EVAL1Z

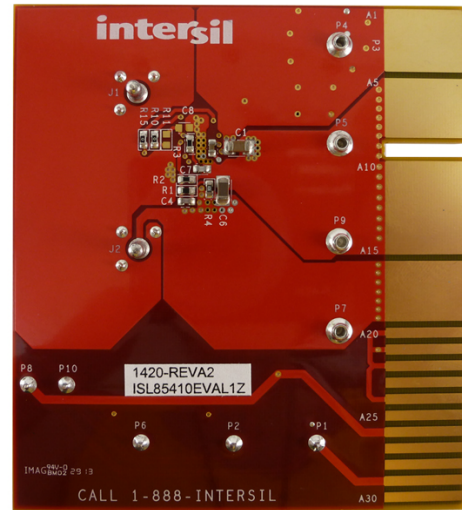

FIGURE 3. BACK OF EVALUATION BOARD ISL85410EVAL1Z



FIGURE 4. FRONT OF EVALUATION BOARD ISL854102EVAL1Z



FIGURE 5. BACK OF EVALUATION BOARD ISL854102EVAL1Z

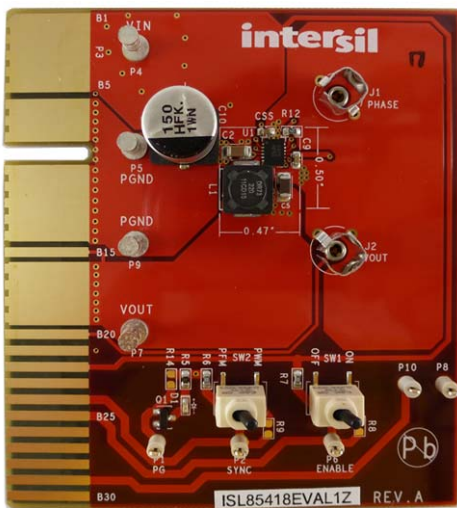

FIGURE 6. FRONT OF EVALUATION BOARD ISL85418EVAL1Z



FIGURE 7. BACK OF EVALUATION BOARD ISL85418EVAL1Z

Schematics

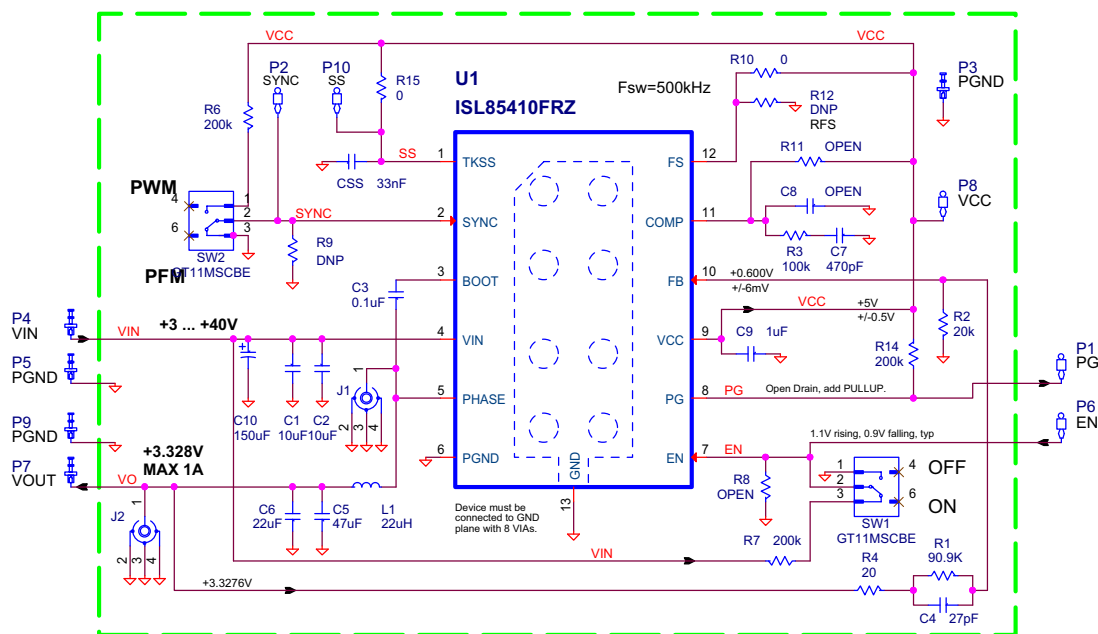

FIGURE 8. ISL85410EVAL1Z SCHEMATIC

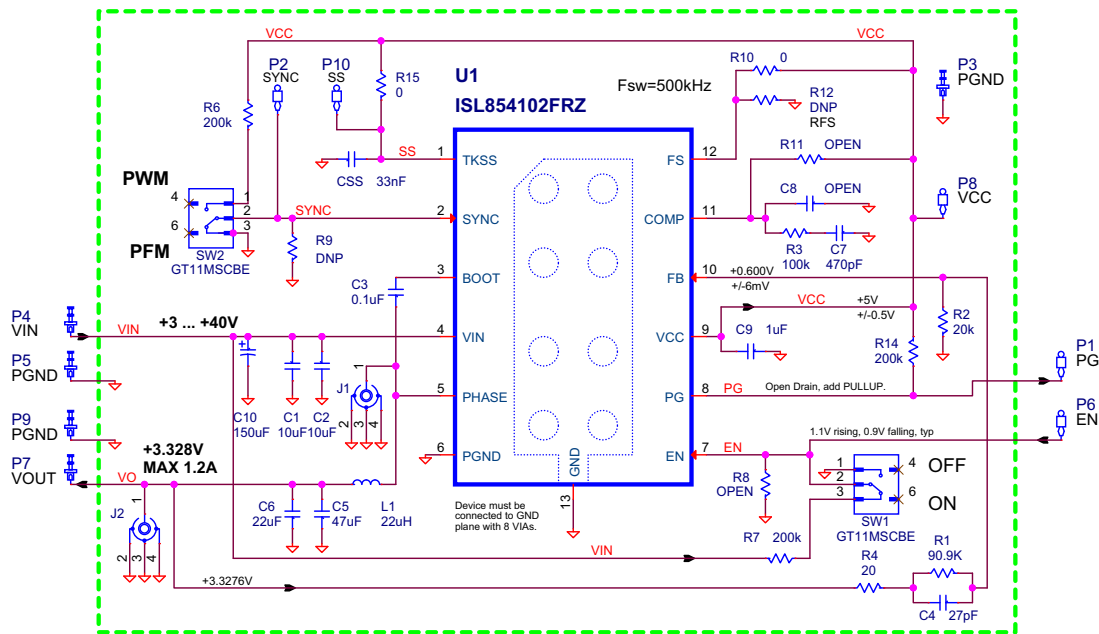

FIGURE 9. ISL854102EVAL1Z SCHEMATIC

Schematics (Continued)

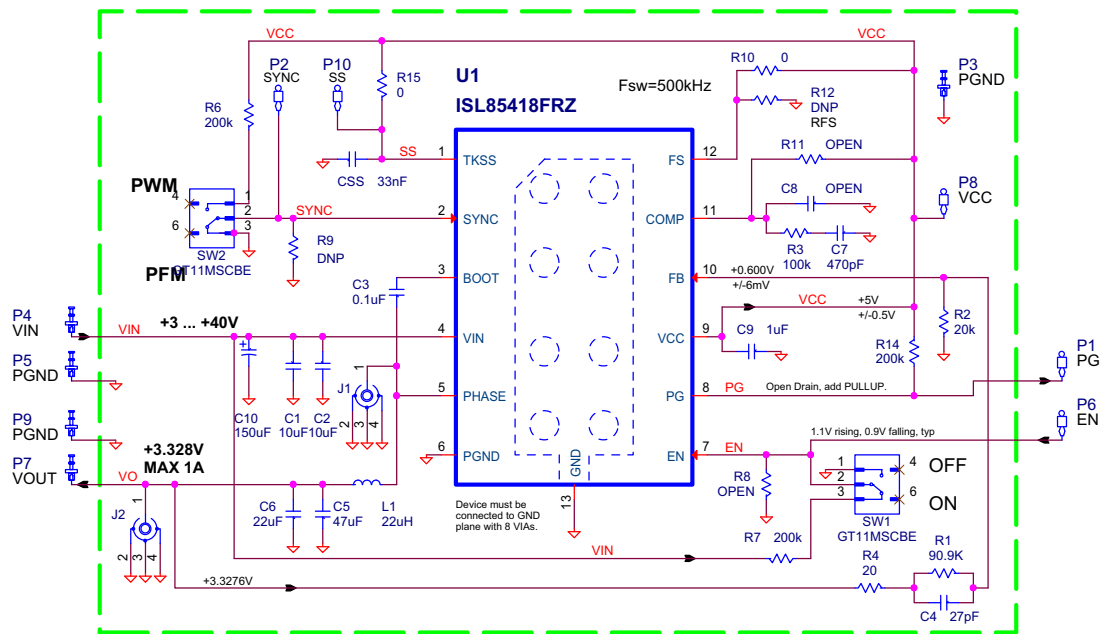

FIGURE 10. ISL85418EVAL1Z SCHEMATIC

Bill of Materials

MANUFACTURER PART	QTY	UNITS	REFERENCE DESIGNATOR	DESCRIPTION	MANUFACTURER
ISL85400EVAL1ZREVAPCB	1	ea	SEE LABEL-RENAME BOARD	PWB-PCB, ISL85400EVAL1Z, REVA, ROHS	INTERSIL
EEE-FK1H151P	1	ea	C10	CAP, SMD, 10.3mm, 150μF, 50V, 20%, ROHS, ALUM.ELEC.	PANASONIC
06035C104KAT2A	1	ea	C3	CAP, SMD, 0603, 0.1μF, 50V, 10%, X7R, ROHS	AVX
GRM188R61C105KA12D	1	ea	C9	CAP, SMD, 0603, 1μF, 16V, 10%, X5R, ROHS	MURATA
C1608C0G1H270J	1	ea	C4	CAP, SMD, 0603, 27pF, 50V, 5%, NP0, ROHS	TDK
C0603X7R160-333KNE	1	ea	CSS	CAP, SMD, 0603, 33000pF, 16V, 10%, X7R, ROHS	VENKEL
ECJ-1VC1H471J	1	ea	C7	CAP, SMD, 0603, 470pF, 50V, 5%, NP0, ROHS	PANASONIC
	0	ea	C8	CAP, SMD, 0603, DNP-PLACE HOLDER, ROHS	
C3216X5R1H106K	2	ea	C1, C2	CAP, SMD, 1206, 10μF, 50V, 10%, X5R, ROHS	TDK
GRM31CR60J476ME19L			C5	CAP, SMD, 1206, 47μF, 6.3V, 20%, X5R, ROHS	MURATA
ECJ-DV50J226M	2	ea	C6	CAP, SMD, 1206, 22μF, 6.3V, 20%, X5R, ROHS	PANASONIC

Bill of Materials (Continued)

MANUFACTURER PART	QTY	UNITS	REFERENCE DESIGNATOR	DESCRIPTION	MANUFACTURER
DR73-220-R	1	ea	L1	COIL-PWR INDUCTOR, SMD, 7.6mm, 22µH, 20%, 1.62A, ROHS	COOPER/COILTRONICS
131-4353-00	2	ea	J1, J2	CONN-SCOPE PROBE TEST PT, COMPACT, PCB MNT, ROHS	TEKTRONIX
1514-2	4	ea	P4, P5, P7, P9	CONN-TURRET, TERMINAL POST, TH, ROHS	KEYSTONE
5002	5	ea	P1, P2, P6, P8, P10	CONN-MINI TEST POINT, VERTICAL, WHITE, ROHS	KEYSTONE
LTST-C190KGKT	1	ea	D1	LED, SMD, 0603, GREEN CLEAR, 2V, 20mA, 571nm, 35mcd, ROHS	LITEON/VISHAY
ISL85410FRZ for ISL85410EVAL1Z, ISL85418FRZ for ISL85418EVAL1Z, ISL854102FRZ for ISL854102EVAL1Z	1	ea	U1	IC 40V BUCK REGULATOR, 12P, DFN, 3x4, ROHS	INTERSIL
2N7002LT1G	1	ea	Q1	TRANSISTOR-MOS, N-CHANNEL, SMD, SOT23, 60V, 115mA, ROHS	ON SEMICONDUCTOR
ERJ-3EKF20R0V	1	ea	R4	RES, SMD, 0603, 20Ω, 1/10W, 1%, TF, ROHS	PANASONIC
CR0603-10W-000T	2	ea	R10, R15	RES, SMD, 0603, 0Ω, 1/10W, TF, ROHS	VENKEL
CR0603-10W-1003FT	1	ea	R3	RES, SMD, 0603, 100k, 1/10W, 1%, TF, ROHS	VENKEL
RK73H1JTTD2001F	1	ea	R5	RES, SMD, 0603, 2k, 1/10W, 1%, TF, ROHS	KOA
CR0603-10W-2002FT	0	ea	R2	RES, SMD, 0603, 20k, 1/10W, 1%, TF, ROHS	VENKEL
CR0603-10W-2003FT	2	ea	R6, R7	RES, SMD, 0603, 200k, 1/10W, 1%, TF, ROHS	VENKEL
ERJ-3EKF9092V	1	ea	R1	RES, SMD, 0603, 90.9k, 1/10W, 1%, TF, ROHS	PANASONIC
	0	ea	R8, R9, R11, R12, R14	RES, SMD, 0603, DNP-PLACE HOLDER, ROHS	
GT11MSCBE	2	ea	SW1, SW2	SWITCH-TOGGLE, SMD, 6PIN, SPDT, 2POS, ON-ON, ROHS	ITT INDUSTRIES/C&K DIVISION
DNP	0	ea	P3 (3VH30/1JN5)	DO NOT POPULATE OR PURCHASE	

Board Layout

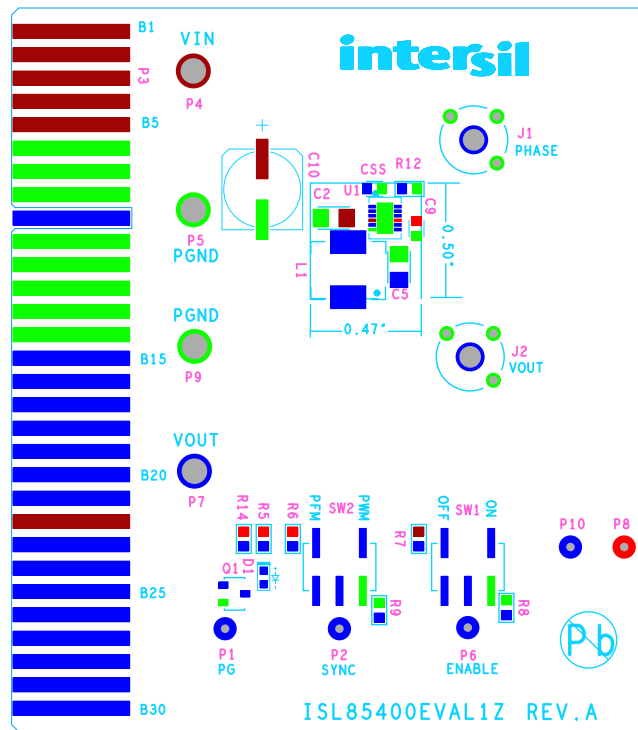

FIGURE 11. SILK SCREEN TOP

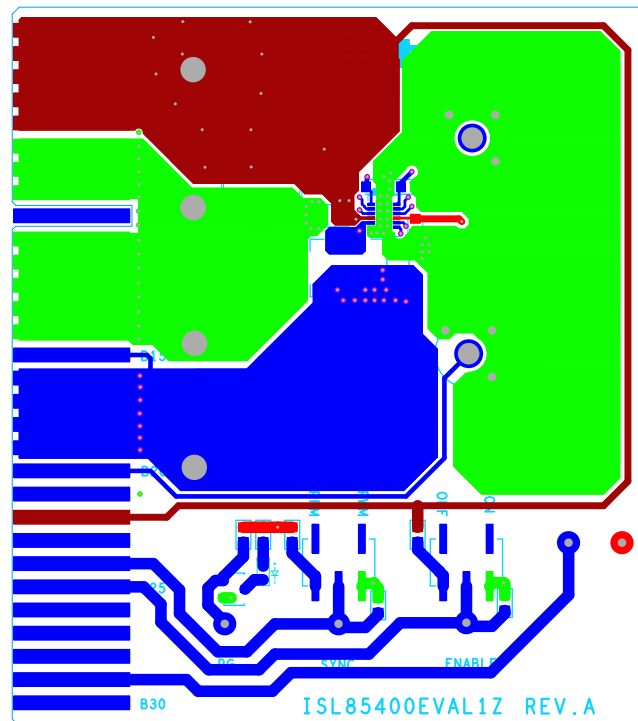

FIGURE 12. LAYER 1

Board Layout (Continued)

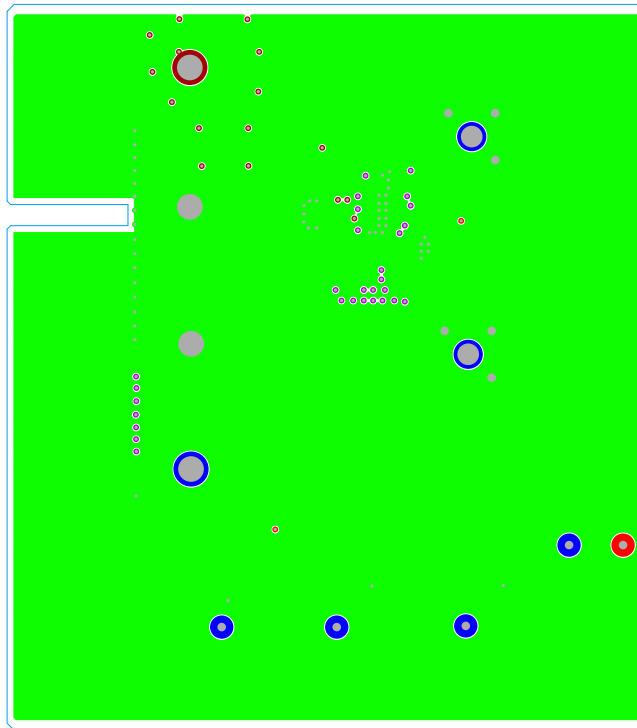

FIGURE 13. LAYER 2

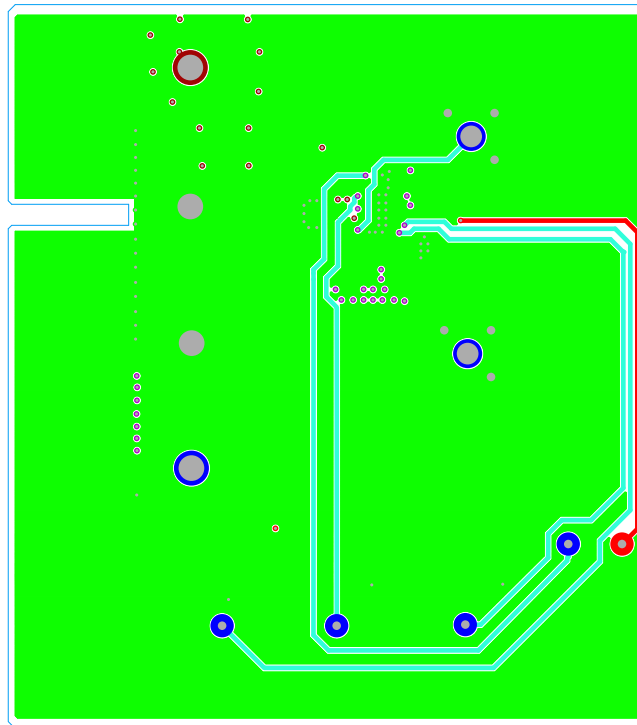

FIGURE 14. LAYER 3

Board Layout (Continued)

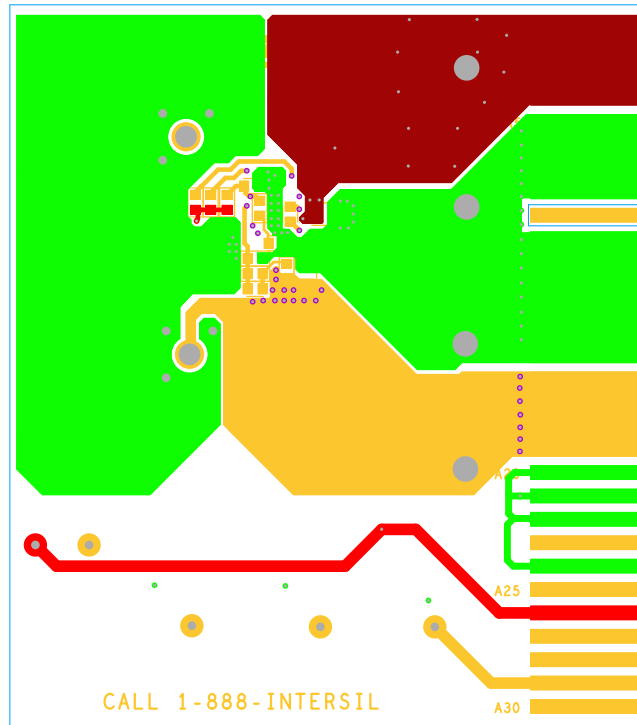

FIGURE 15. LAYER 4

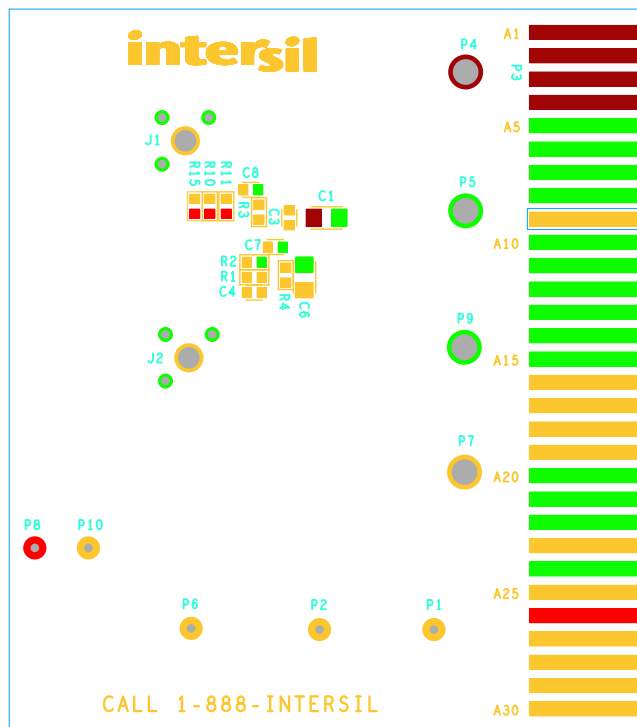

FIGURE 16. SILK SCREEN BOTTOM

Typical Performance Curves

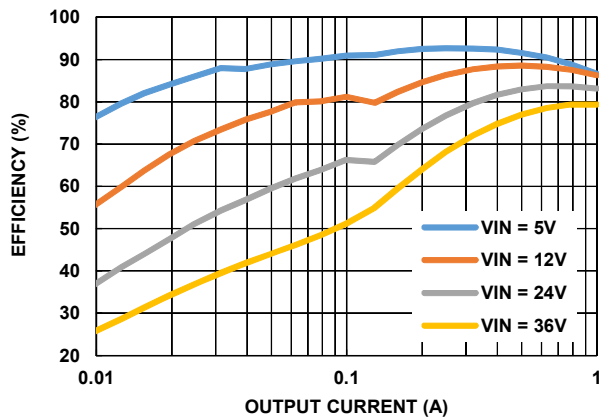

FIGURE 17. EFFICIENCY, PFM (ISL85410EVAL1Z, $V_{OUT} = 3.3V$)

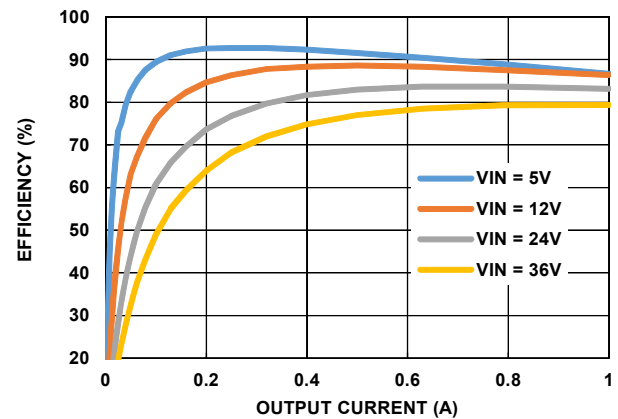

FIGURE 18. EFFICIENCY, PWM (ISL85410EVAL1Z, $V_{OUT} = 3.3V$)

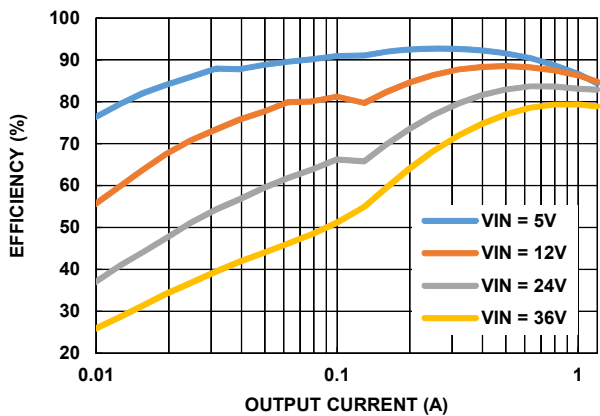

FIGURE 19. EFFICIENCY, PFM (ISL854102EVAL1Z, $V_{OUT} = 3.3V$)

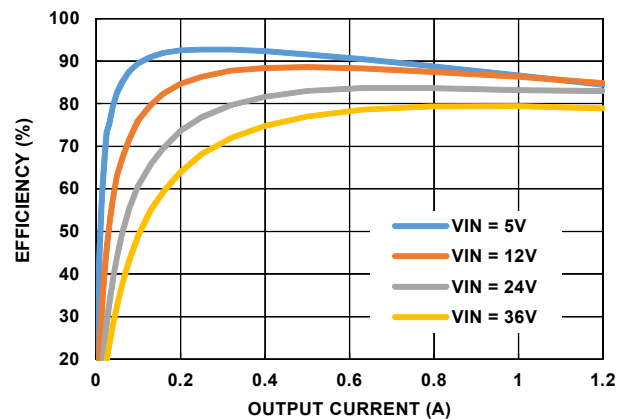

FIGURE 20. EFFICIENCY, PWM (ISL854102EVAL1Z, $V_{OUT} = 3.3V$)

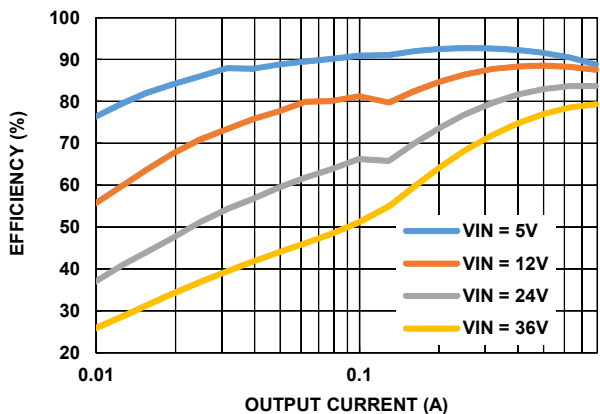

FIGURE 21. EFFICIENCY, PFM (ISL85418EVAL1Z, $V_{OUT} = 3.3V$)

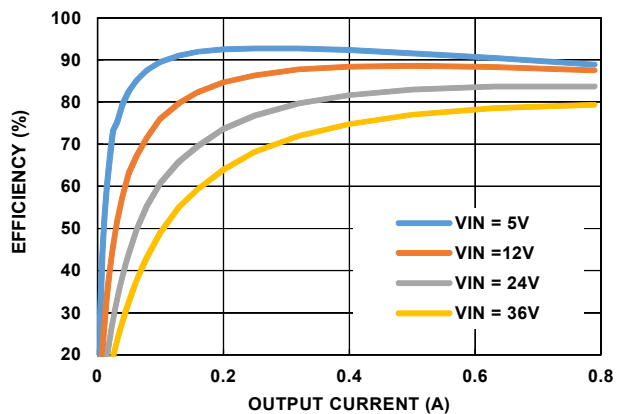

FIGURE 22. EFFICIENCY, PWM (ISL85418EVAL1Z, $V_{OUT} = 3.3V$)