

ISL9104xxxxEVAL1Z, ISL9104AxxxxEVAL1Z

Evaluation Board

AN1522
Rev 1.00
March 15, 2010

Description

The ISL9104 evaluation kit provides a test platform for the ISL9104 4.3MHz low quiescent current, high efficiency integrated step-down regulator. The ISL9104 is capable of delivering 500mA output current. For adjustable output option, the output voltage can be programmed through the external feedback resistors R1 and R2 on the board (on board the default output voltage is set to be 1.6V but it can be programmed for the range of 0.8V to V_{IN}). It is also offered in many fixed output voltage options including 1.2V, 1.5V, 1.8V, 2.0V, 2.5V, 2.8V and 3.3V.

The complete ISL9104 regulator is located at the center of the board. On the left side of the board are the connectors for the input power source (V_{IN} and GND). The output connectors are located on the right side (V_O and GND). Jumper JP1 allows the user to enable or disable the IC.

The evaluation board schematic, layout and bill of materials (BOM) can be found at the end of this application note.

Pinout

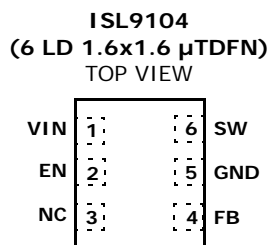

Features

- A Complete Evaluation Platform for ISL9104, ISL9104A
- Convenient Jumpers for Enable/Disable Operation
- Pb-Free (RoHS Compliant)

Recommended Equipment

The following instruments are recommended for testing:

- Power supplies: DC 6.5V/1A
- Electronic load: 0mA to 500mA
- Multimeters
- Function generator
- Oscilloscope
- Cables and wires

Recommended Operating Conditions

- Input voltage: from 2.7V or ($V_{OUT} + V_{DROP}$) whichever is higher to 6.0V. Here $V_{DROP} = I_{LOAD} * (r_{DSON_PFET} + R_L)$. r_{DSON_PFET} is the ON-resistance of the high-side power P-MOSFET and R_L is the DCR of the inductor.
- Loading current: 0mA ~ 500mA
- Ambient temperature range: -40°C ~ +85°C

NOTE: For the fixed output options, the output voltage is pre-set in the factory. For the adjustable output options, the output voltage can be programmed through the external resistor network from V_{OUT} to FB to GND, where $V_{OUT} = 0.8V * (1 + R2/R1)$, please refer to ISL9104, ISL9104A data sheet [FN6829](#) for recommended component values. On board, the default output voltage is set at 1.6V for the adjustable output options.

Setup Guide

1. Place shunt on JP1 at the position of "Enable" to enable the device. Put shunt on JP1 at the position of "Disable" will disable the device.
2. Connect the DC power supply between V_{IN} and GND connectors. Make sure the power supply has enough supply current capability. Do not adjust the V_{IN} higher than the recommended maximum supply voltage (6.0V).
3. Connect the output to a load (resistor or electronic load).
4. Turn on the input power supply and evaluate the device.

Ordering Information

| PART NUMBER | DESCRIPTION |
|--------------------|--|
| ISL9104IRUNEVAL1Z | Evaluation Board for ISL9104IRUNZ-T (3.3V) |
| ISL9104IRUJEVAL1Z | Evaluation Board for ISL9104IRUJZ-T (2.8V) |
| ISL9104IRUFEVAL1Z | Evaluation Board for ISL9104IRUFZ-T (2.5V) |
| ISL9104IRUDEVAL1Z | Evaluation Board for ISL9104IRUDZ-T (2.0V) |
| ISL9104IRUCEVAL1Z | Evaluation Board for ISL9104IRUCZ-T (1.8V) |
| ISL9104IRUBEVAL1Z | Evaluation Board for ISL9104IRUBZ-T (1.5V) |
| ISL9104IRUWEVAL1Z | Evaluation Board for ISL9104IRUWZ-T (1.2V) |
| ISL9104IRUAEVAL1Z | Evaluation Board for ISL9104IRUAZ-T (Adjustable) |
| ISL9104AIRUNEVAL1Z | Evaluation Board for ISL9104AIRUNZ-T (3.3V) |

Ordering Information (Continued)

| PART NUMBER | DESCRIPTION |
|-----------------------------|---|
| ISL9104 AIRUJ EVAL1Z | Evaluation Board for ISL9104AIRUJZ-T (2.8V) |
| ISL9104 AIRUF EVAL1Z | Evaluation Board for ISL9104AIRUFZ-T (2.5V) |
| ISL9104 AIRUD EVAL1Z | Evaluation Board for ISL9104AIRUDZ-T (2.0V) |
| ISL9104 AIRUC EVAL1Z | Evaluation Board for ISL9104AIRUCZ-T (1.8V) |
| ISL9104 AIRUB EVAL1Z | Evaluation Board for ISL9104AIRUBZ-T (1.5V) |
| ISL9104 AIRUW EVAL1Z | Evaluation Board for ISL9104AIRUWZ-T (1.2V) |
| ISL9104 AIRUA EVAL1Z | Evaluation Board for ISL9104AIRUAZ-T (Adjustable) |

Evaluation Board Schematic

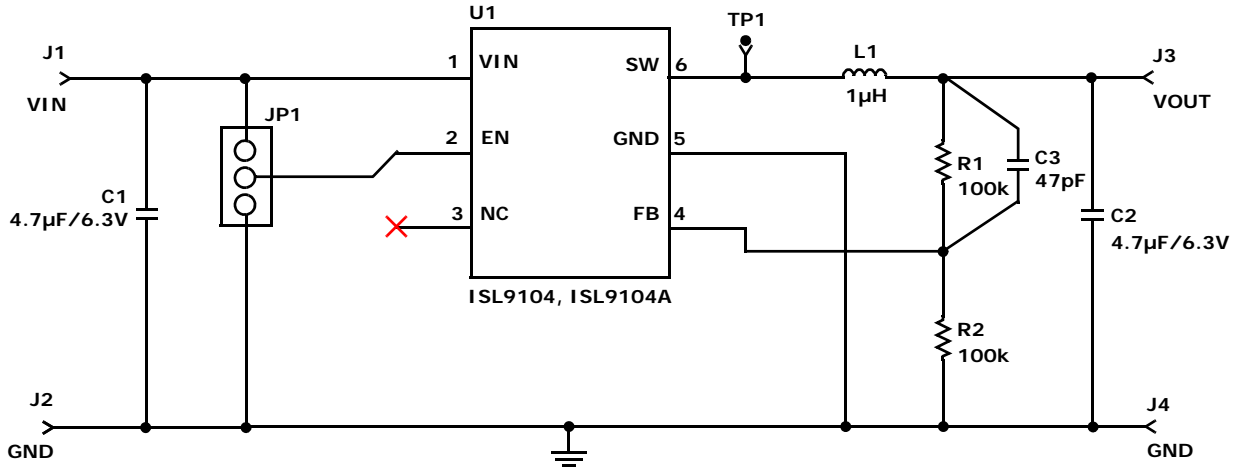

NOTE: FOR THE FIXED OUTPUT VOLTAGE OPTIONS, R1 = 0, C3 AND R2 NOT POPULATED

FIGURE 1. ISL9104, ISL9104A EVALUATION BOARD SCHEMATIC

Bill of Materials (BOM)

| ITEM | QTY | REFERENCE | PART DESCRIPTION | PCB FOOTPRINT | PART NUMBER | VENDOR | NOTE |
|------|-----|------------------|---|-------------------------|-------------------------|-----------|--|
| 1 | 1 | U1 | ISL9104 or ISL9104A | 1.6x1.6 6 Ld μ TDFN | | Intersil | |
| 2 | 2 | C1, C2 | Capacitor, SMD, 4.7 μ F, 10%, X5R | 0603 | GRM188R60J475KE19D | Murata | |
| 3 | 1 | C3 | Capacitor, SMD 47pF, 5%, X7R | 0402 | GRM36COG470J050AQ | Murata | Only populated for boards with part numbers ISL9104IRUAEVAL1Z and ISL9104AIRUAEVAL1Z. For boards with other part numbers, it is unpopulated. |
| 4 | 1 | R1 | Resistor, SMD, 100k Ω , 1%, 0.1W | 0402 | ERJ2RKF1003 | Panasonic | Only populated for boards with part numbers ISL9104IRUAEVAL1Z and ISL9104AIRUAEVAL1Z. For boards with other part numbers, it is unpopulated. |
| 5 | 1 | R1 | Resistor, SMD, 0 Ω | 0402 | Generic | Generic | Populated for all boards with other part numbers EXCEPT ISL9104IRUAEVAL1Z and ISL9104AIRUAEVAL1Z |
| 6 | 1 | R2 | Resistor, SMD, 100k Ω , 1% | 0402 | ERJ2RKF1003 | Panasonic | Only populated for boards with part numbers ISL9104IRUAEVAL1Z and ISL9104AIRUAEVAL1Z. For boards with other part numbers, it is unpopulated. |
| 7 | 1 | L1 | Inductor, 1 μ H | | L1207C1R0MPWS | KEMET | |
| 8 | 4 | VIN, VO, GND(x2) | Connector | - | 3156-1-00-15-00-00-08-0 | Mill-Max | |
| 9 | 1 | TP1 | Scope Probe Test Point | - | 131503100 | Tektronix | Not populated |
| 10 | 1 | JP1 | Connect Header, 1X3 | - | 68000-236-1X3 | BERG/FCI | |

PCB Layout

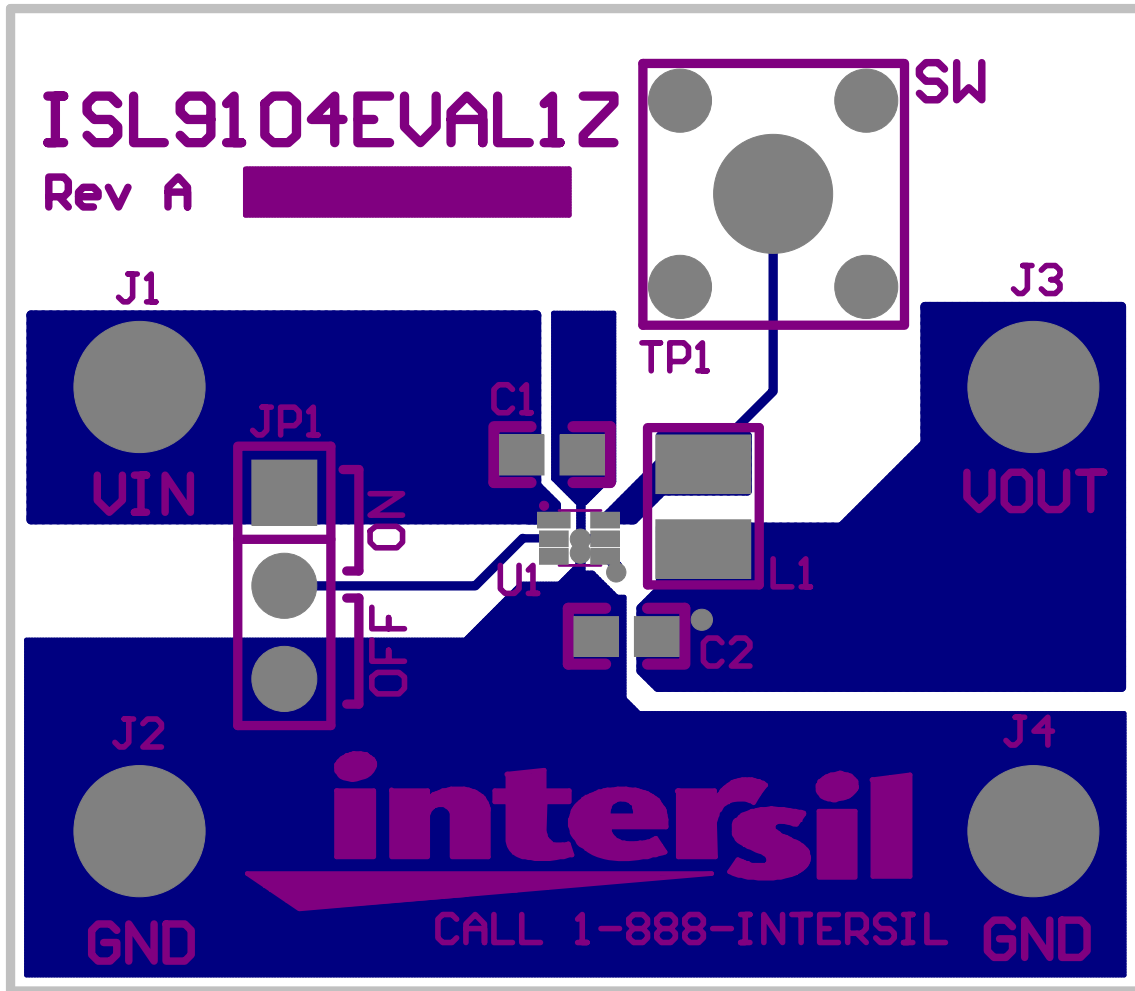

FIGURE 2. TOP SILK LAYER

PCB Layout (Continued)

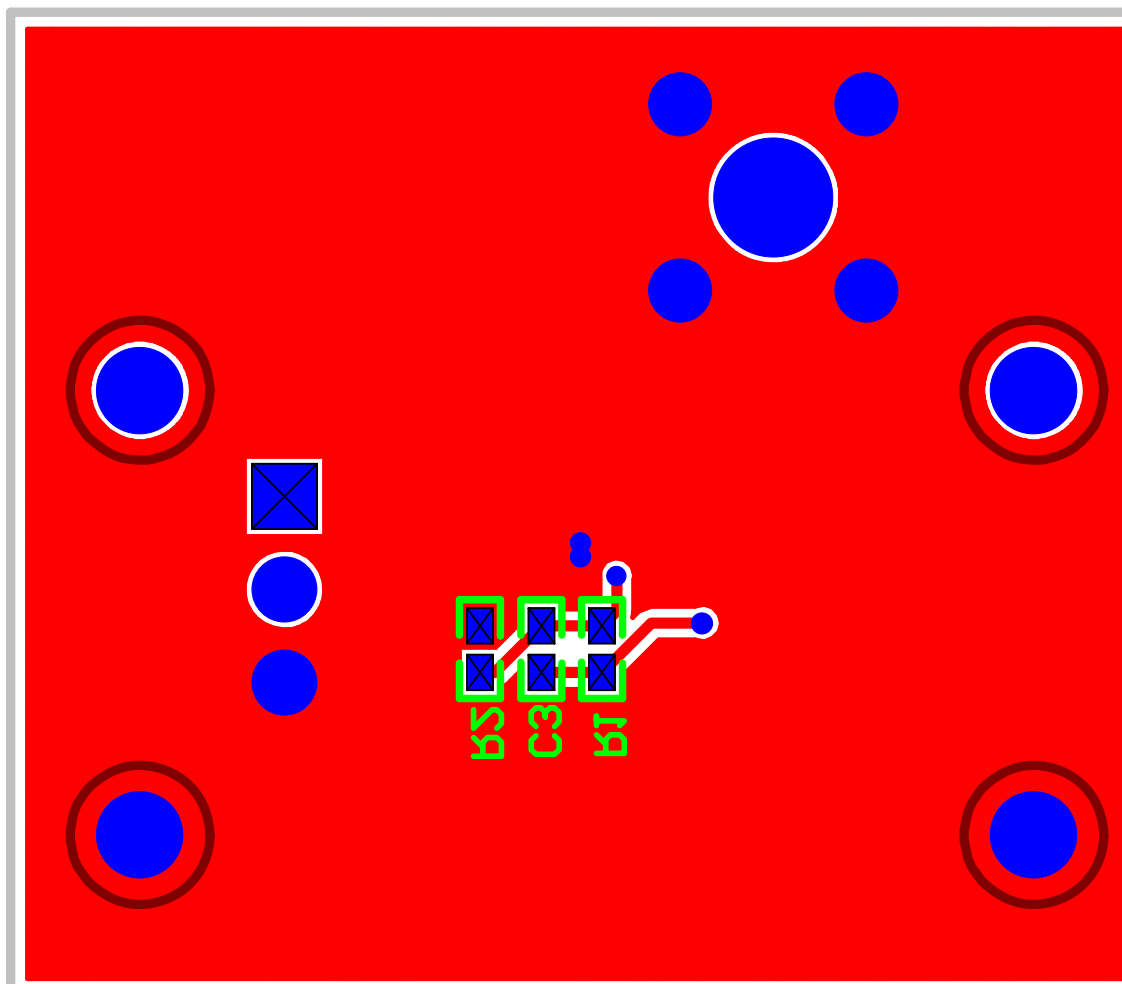

FIGURE 3. BOTTOM SILK LAYER

PCB Layout (Continued)

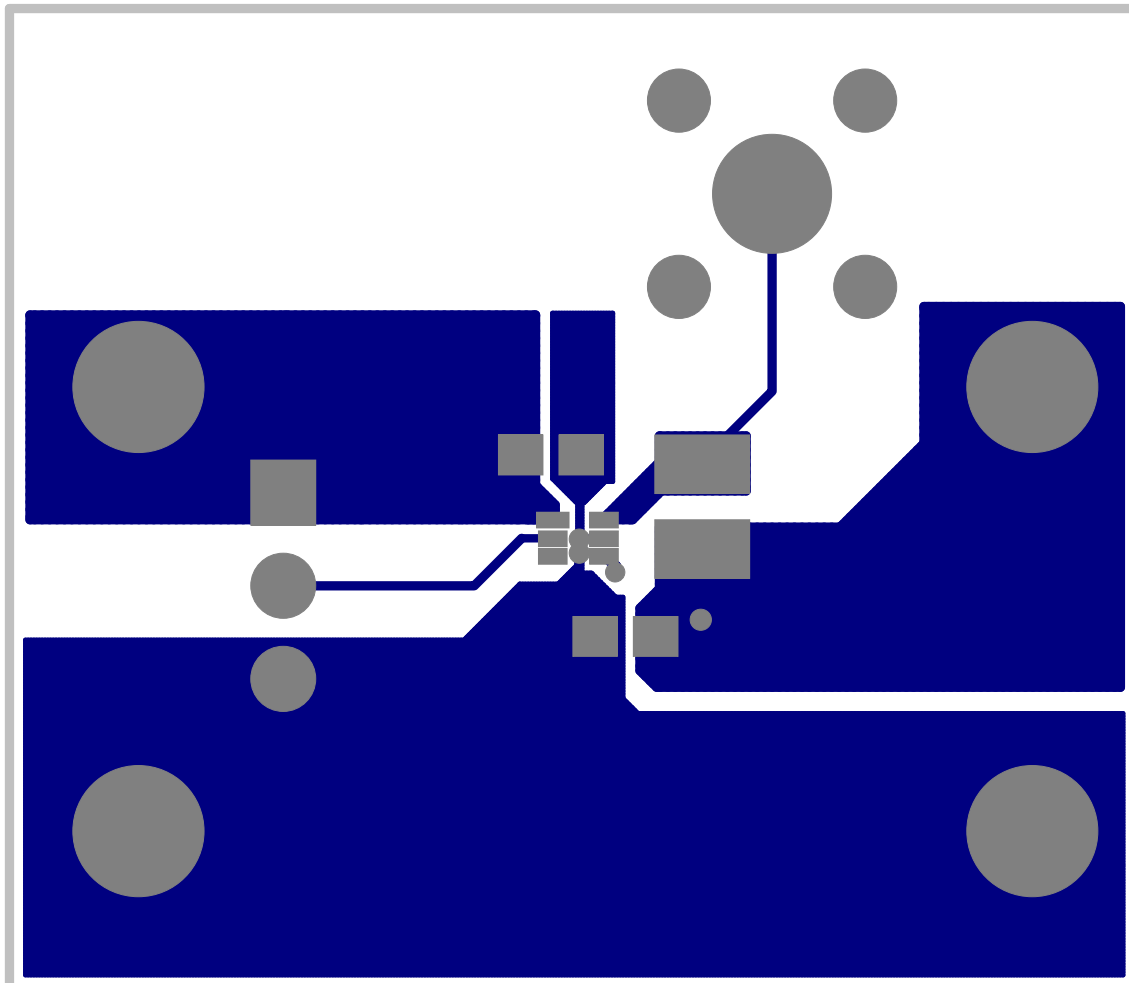

FIGURE 4. TOP LAYER

PCB Layout (Continued)

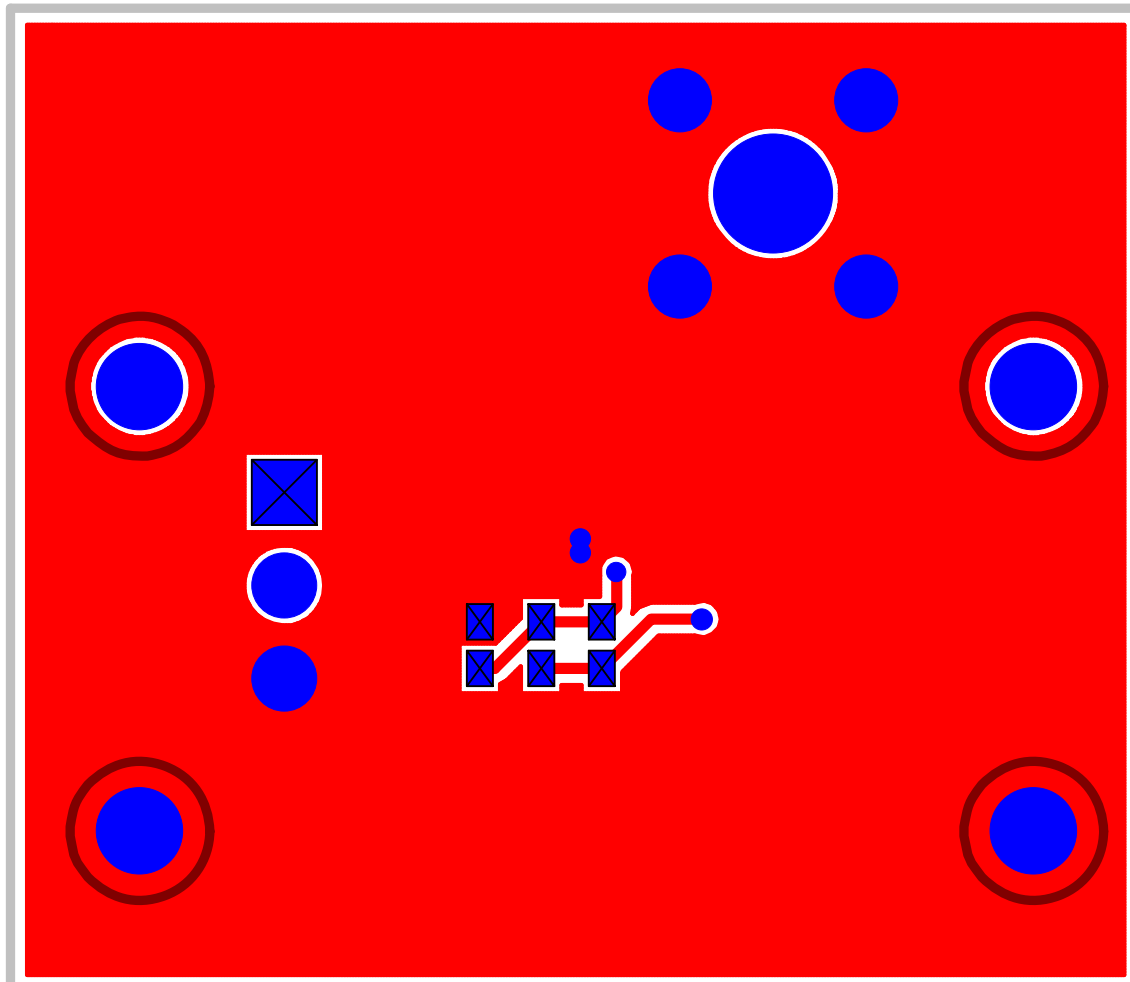

FIGURE 5. BOTTOM LAYER