

ISL9105EVAL1Z

Evaluation Board Application\Manual

AN1346
Rev 0.00
August 3, 2007

Description

The ISL9105EVAL1Z is an evaluation kit for the ISL9105 1.6MHz 600mA low quiescent current, high efficiency integrated step-down regulator. The ISL9105 is capable of delivering up to 600mA output current with an output voltage range of 0.8V to $\sim V_{IN}$. The output voltage is set by two voltage divider resistors of R_2 and R_3 on the board. The default output voltage is set to be 1.6V on the evaluation board and can be modified by changing the R_2 value.

The complete ISL9105 regulator is located at the center of the board. On the left side of the board are the connectors for the input power source (J1 VIN; J2 GND). The output connectors are located on the right side (J4 VO; J5 GND). The other two test points are for the POR (J3) and RSI (J6) signals respectively, as labelled on the board. The RSI input needs either be driven to a low or a high logic input (Please refer to the ISL9105 datasheet, FN6415 for more details regarding RSI function). **Do not leave the RSI input signal floating.** The open-drain POR signal is pulled up to the V_{IN} through a 100k Ω resistor (R_1). Jumper JP1 allows the user to enable or disable the IC. Jumper JP2 is the mode selection input. **Do not leave the EN or the MODE signal floating.** The evaluation board also offers one oscilloscope probe tip connector connected to PHASE pin to minimize the switching noise during the evaluation. One test point (labeled as FB) is connected to the FB pin on the board in order to monitor the FB voltage.

The evaluation board schematic, layout and bill-of-materials (BOM) can be found at the end of this application note.

Ordering Information

PART NUMBER	DESCRIPTION
ISL9105EVAL1Z	Evaluation Board for ISL9105

Pinout

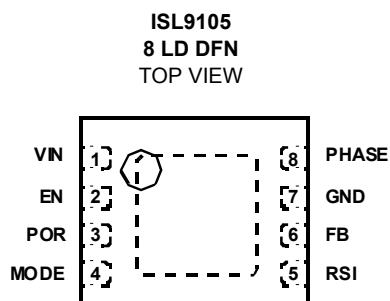

Features

- A Complete Evaluation Platform for ISL9105
- Convenient Jumpers for Enable/Disable, Operation Mode Selection
- 2.0x1.6 Square Inches Board Size Handy for Evaluation
- Pb-Free Plus Anneal Available (RoHS Compliant)

What is Needed

The following instruments will be needed to perform testing:

- Power supplies: DC 10V/1A
- DC Electronic load: 10V/1A
- Multimeters
- Function generator
- Oscilloscope
- Cables and wires

Specifications

Table 1 shows the recommended operation conditions for using the ISL9105EVAL1Z.

TABLE 1. RECOMMENDED OPERATION CONDITIONS

PARAMETER	MIN	TYP	MAX	UNIT
Input Voltage	2.7	-	5.5	V
Output Voltage (Note)	-	1.6	-	V
Maximum Output Current	600	-	-	mA

NOTE: The output voltage can be set to other values by changing the R_2 value, $V_{OUT} = 0.8V \cdot (1 + R_2/R_3)$.

Evaluation Board Setup

The following are steps for setting up the evaluation board:

1. Connect Jumper JP1 at the position of "Enable" to enable the device. Connect JP1 at the position of "Disable" will disable the device.
2. Connect Jumper JP2 either at the position of "SKIP" or "Forced PWM". With JP2 connected at the position of "SKIP", the device enters skip mode under light load condition; with JP2 connected at the position of "FORCED PWM", the device always operates under PWM mode regardless of the load condition.
3. Connect the RSI input to either ground or VIN. Do not leave it floating. Please refer to the ISL9105 datasheet, FN6415 for more details regarding the function of RSI.
4. Connect a DC power supply with voltage range of 2.7V to $\sim 5.5V$ to VIN (J1) and GND (J2) connectors. Make sure the power supply has enough supply current capability. Do not adjust the V_{IN} higher than the recommended maximum supply voltage (5.5V).
5. Connect the output to a load (resistor or electronic load).
6. Turn on the input power supply and evaluate the device.

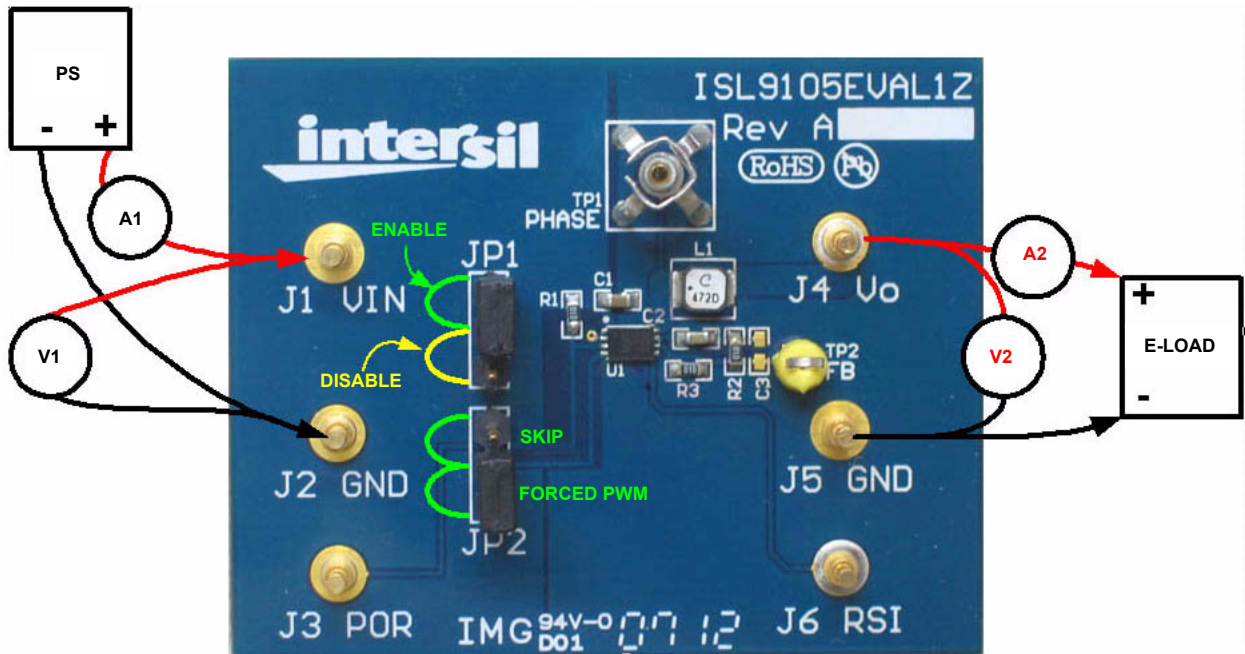

FIGURE 1. ISL9105EVAL1Z PCB

ISL9105EVAL1Z Schematic

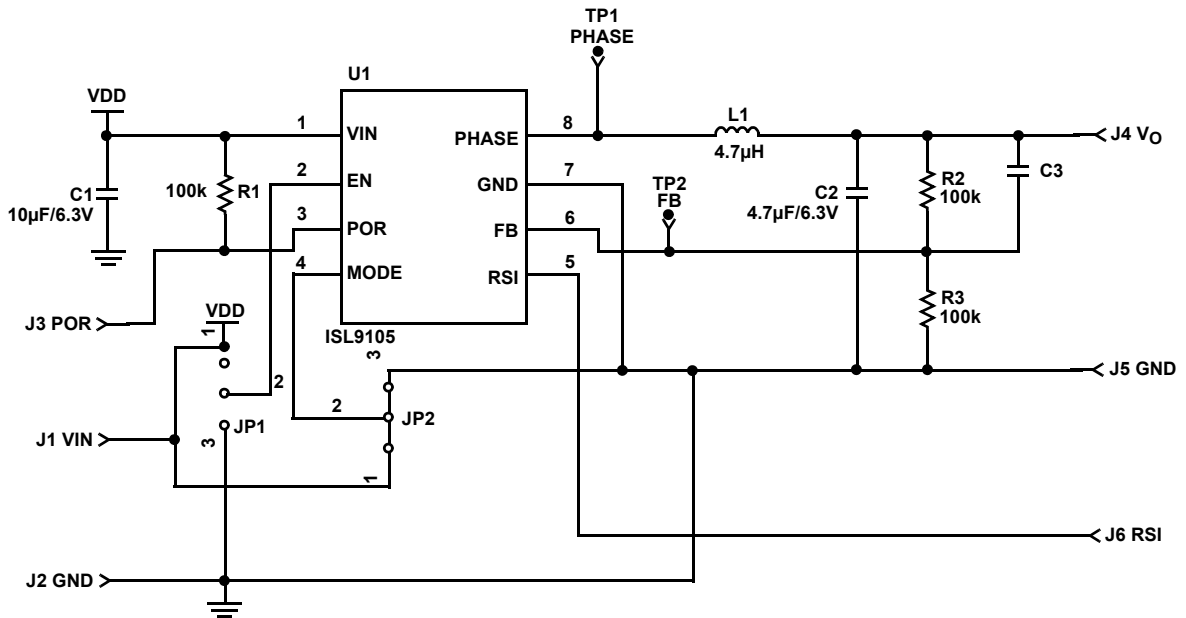

FIGURE 2. ISL9105EVAL1Z SCHEMATIC

ISL9105EVAL1Z Bill of Materials (BOM)

ITEM	QTY	REFERENCE	PART DESCRIPTION	PCB FOOTPRINT	PART NUMBER	VENDOR
1	1	U1	ISL9105	2x3 8 Ld DFN	ISL9105	Intersil
2	1	C1	Capacitor, SMD, 10µF/6.3V, 10%, X5R	0603	GRM188R60J106	Murata
3	1	C2	Capacitor, SMD, 4.7µF/6.3V, 10%, X5R	0603	GRM188R60J475K	Murata
4	1	C3	Capacitor, not populated	0603	N/A	N/A
5	3	R1, R2, R3	100kΩ,1%, SMD Resistor	0603	RC0603FR-07100KL	Yageo
6	1	L1	Inductor, 4.7µH	-	LPS3015-472ML	Coilcraft
7	6	J1-J6	Turrent Terminal Pin	-	3156-1-00-15-00-00-08-0	Mill-Max
8	1	TP1	Scope Probe Test Point	-	131503100	Tektronix
9	1	TP2	Test Point, Yellow	-	5014	Keystone Electronics
10	2	JP1, JP2	Connect Header, 1X3	-	68000-236-1X3	BERG/FCI

PCB Layout

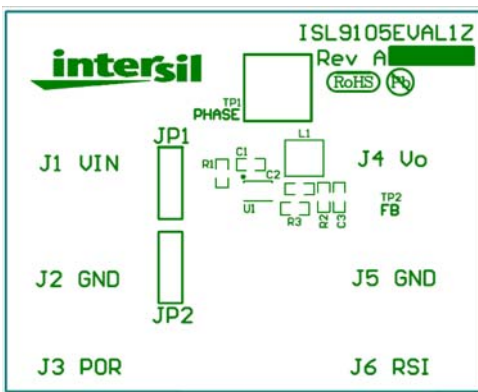

FIGURE 3. SILK LAYER

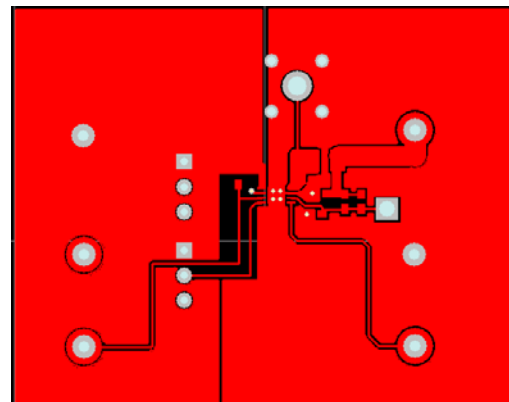

FIGURE 4. TOP LAYER

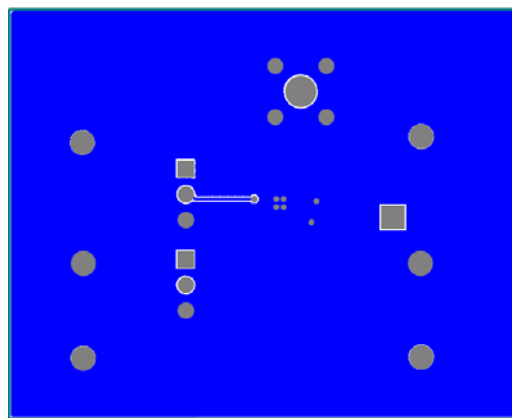

FIGURE 5. BOTTOM LAYER