

ISL91106, ISL91106A

High Efficiency High Current Buck-Boost Regulator with Bypass Mode

FN8679

Rev 2.00

November 20, 2015

The [ISL91106](#) and [ISL91106A](#) are highly integrated buck-boost switching regulators that accept input voltages either above or below the regulated output voltage. Unlike other buck-boost regulators, these regulators automatically transitions between operating modes without significant output disturbance. The devices also include a selectable bypass mode for low power consumption in applications that have a sleep or low-power mode.

These devices are capable of delivering up to 2A of output current ($P_{VIN} = 2.8V$, $V_{OUT} = 3.3V$) and provide excellent efficiency due to their fully synchronous 4-switch architecture. No load quiescent current of only $45\mu A$ also optimizes efficiency under light-load conditions.

The ISL91106 and ISL91106A are designed for stand-alone applications. They support 3.3V and 3.4V fixed output voltages or variable output voltages with an external resistor divider. Output voltages as low as 1V or as high as 5.2V are supported using an external resistor divider.

The ISL91106 and ISL91106A require only a single inductor and very few external components. Power supply solution size is minimized by a $2.15mm \times 1.51mm$ WLCSP and a 2.5MHz switching frequency, which further reduces the size of external components.

Related Literature

- AN1959, "ISL91106IIx-EVZ, ISL91106AIIx -EVZ Evaluation Board User Guide"

Features

- ISL91106 with 3.8A switches
- ISL91106A with 4.2A switches
- Accepts input voltages above or below regulated output voltage
- Automatic and seamless transitions between buck and boost modes
- Input voltage range: 1.8V to 5.5V
- Output current ($P_{VIN} = 2.8V$, $V_{OUT} = 3.3V$):
 - 2.1A (ISL91106A)
 - 2A (ISL91106)
- High efficiency: up to 96%
- $45\mu A$ quiescent current maximizes light load efficiency
- 2.5MHz switching frequency minimizes external component size
- Selectable forced PWM mode
- Selectable bypass power saving mode
- Fully protected for over-temperature, overcurrent and undervoltage
- Small $2.15mm \times 1.51mm$ WLCSP

Applications

- Smartphones and tablet PCs
- Wireless communication devices
- 2G/3G/4G power amplifiers

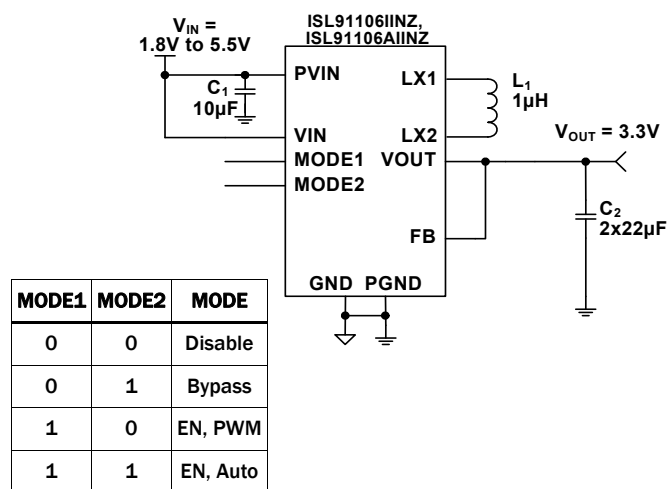

FIGURE 1. TYPICAL APPLICATION ISL91106IIxZ, ISL91106IIQZ OR ISL91106IIAZ, ISL91106AIIAZ

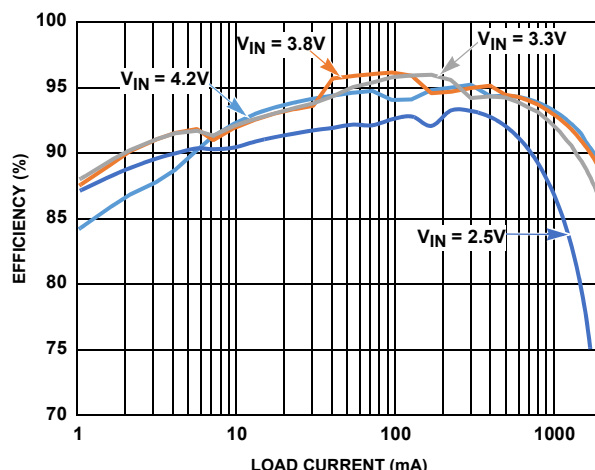

FIGURE 2. EFFICIENCY vs OUTPUT CURRENT ($V_{OUT} = 3.3V$)

© Copyright Intersil Americas LLC 2014-2015. All Rights Reserved.
All trademarks and registered trademarks are the property of their respective owners.

For additional products, see www.intersil.com/en/products.html

Intersil products are manufactured, assembled and tested utilizing ISO9001 quality systems as noted in the quality certifications found at www.intersil.com/en/support/qualandreliability.html

Intersil products are sold by description only. Intersil may modify the circuit design and/or specifications of products at any time without notice, provided that such modification does not, in Intersil's sole judgment, affect the form, fit or function of the product. Accordingly, the reader is cautioned to verify that datasheets are current before placing orders. Information furnished by Intersil is believed to be accurate and reliable. However, no responsibility is assumed by Intersil or its subsidiaries for its use; nor for any infringements of patents or other rights of third parties which may result from its use. No license is granted by implication or otherwise under any patent or patent rights of Intersil or its subsidiaries.

For information regarding Intersil Corporation and its products, see www.intersil.com