

ISL91127IIX-EVZ

Evaluation Boards

UG045
Rev.1.00
July 15, 2016

Description

The [ISL91127](#) is a high-current buck-boost switching regulator for systems using new battery chemistries. It uses Intersil's proprietary buck-boost algorithm to maintain voltage regulation while providing excellent efficiency and very low output voltage ripple when the input voltage is close to the output voltage. The ISL91127IIN-EVZ, ISL91127II2A-EVZ and ISL91127IIA-EVZ platforms allow quick evaluation of the high performance features of the ISL91127 buck-boost regulator series.

Specifications

The boards are designed to operate at the following operating conditions:

- Input voltage rating from 1.8V to 5.5V
- Resistor programmable output voltage on the ISL91127IIA-EVZ
- Fixed 3.3V output voltage on the ISL91127IIN-EVZ
- Fixed 3.5V output voltage on the ISL91127II2A-EVZ
- Up to 2.2A output current (P_{VIN} = 2.5V, V_{OUT} = 3.3V)
- 2.5MHz switching frequency
- Operating temperature range: -40 °C to +85 °C

Key Features

- Small, compact design
- Jumper selectable EN (enabled/disabled)
- Jumper selectable MODE (auto-PFM/forced-PWM)
- Connectors, test points and jumpers for easy probing

References

[ISL91127](#) Datasheet

Ordering Information

PART NUMBER	DESCRIPTION
ISL91127IIN-EVZ	Evaluation Board for ISL91127IINZ
ISL91127II2A-EVZ	Evaluation Board for ISL91127II2AZ
ISL91127IIA-EVZ	Evaluation Board for ISL91127IIAZ

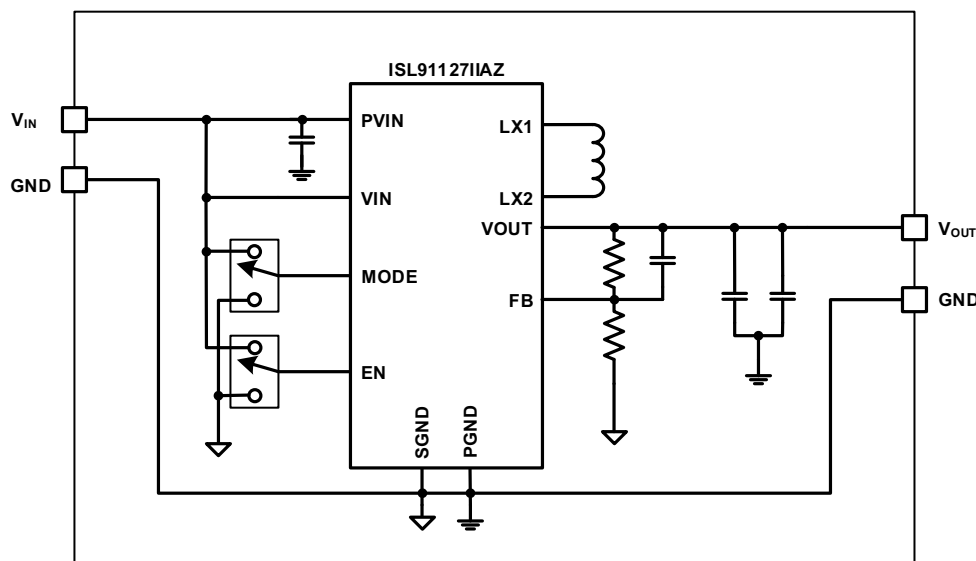

FIGURE 1. ISL91127IIA-EVZ BLOCK DIAGRAM

Functional Description

The ISL91127IIN-EVZ, ISL91127II2A-EVZ and ISL91127IIA-EVZ provide simple platforms to demonstrate the feature of the ISL91127 buck-boost regulator. The ISL91127IIN-EVZ is for the fixed 3.3V output IC ISL91127IINZ. The ISL91127II2A-EVZ is for the fixed 3.5V output IC ISL91127II2AZ and the ISL91127IIA-EVZ is for the adjustable output IC ISL91127IIAZ. The evaluation boards have been functionally optimized for best performance of the ISL91127 IC series. Input power and load connections are provided through multi pin connectors for high current operations.

The ISL91127IIA-EVZ and ISL91127IIN-EVZ evaluation boards are shown in [Figures 4](#) and [5](#). The board's enable function is controlled by the on-board jumper header J3. Similarly, the mode function is controlled by the on-board jumper header J4.

The schematic of the ISL91127IIA-EVZ evaluation board is shown in [Figure 6](#). The schematic for the ISL91127IIN-EVZ and ISL91127II2A-EVZ is shown in [Figure 7](#). The PCB layout images for all layers are shown in [Figures 8](#) through [11](#). The bill of materials of the ISL91127IIA-EVZ is shown in [Table 2](#). The bill of materials of the ISL91127IIN-EVZ and ISL91127II2A-EVZ are shown in [Table 3](#).

Operating Range

The V_{IN} range of the boards is 1.8V to 5.5V. The V_{OUT} range for the ISL91127IIA-EVZ is 2V to 5V. The I_{OUT} range of the boards is 0 to 2A. The operating ambient temperature range is -40°C to $+85^{\circ}\text{C}$.

Recommended PCB Layout

Correct PCB layout is critical for proper operation of the ISL91127. The input and output capacitors should be positioned as closely to the IC as possible. The ground connections of the input and output capacitors should be kept as short as possible, and should be on the component layer to avoid problems that are caused by high switching currents flowing through PCB vias.

Quick Start Guide

For the ISL91127IIA-EVZ board, the default output voltage is set at 3.3V. Should other output voltages be desired, resistor R_2 can be changed to set to a desired voltage as shown in [Table 1](#) (use a resistor with 1% accuracy).

Refer to the following Quick Setup Guide to configure and power up the board for proper operation. During the power on process, the expected waveforms are shown in [Figures 2](#) and [3](#).

Quick Setup Guide

1. Install jumper on J3, shorting EN to VIN.
2. Install jumper on J4, shorting MODE to VIN.
3. Connect power supply to J1, with voltage setting between 1.8V and 5.5V.
4. Connect electronic load to J2.
5. Place scope probes on VOUT test point and other test points of interest.

6. Turn on the power supply.
7. Monitor the output voltage start-up sequence on the scope. The waveforms will look similar to that shown in [Figures 2](#) and [3](#).
8. Turn on the electronic load.
9. Measure the output voltage with the voltmeter. The voltage should regulate within datasheet spec limits.
10. To determine efficiency, measure input and output voltages at the Kelvin sense test points (S+ and S-), which are part of J1 and J2 headers. The bench power supply can be connected to the PVIN and GND headers on J1. The electronic load can be connected to the VOUT and GND headers on J2. Measure the input and output currents. Calculate efficiency based on these measurements.

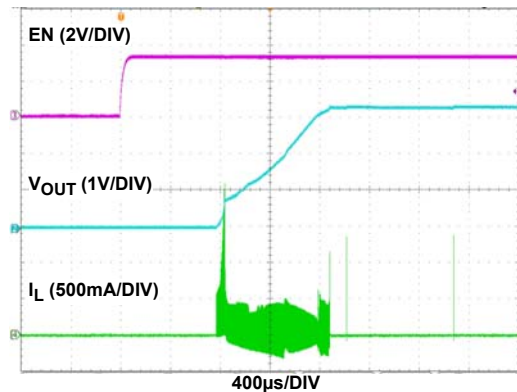

FIGURE 2. START-UP WITH $V_{IN} = 3.6\text{V}$ and $V_{OUT} = 3.3\text{V}$, NO LOAD

TABLE 1. OUTPUT VOLTAGE PROGRAMMING for ISL91127IIA-EVZ

DESIRED OUTPUT VOLTAGE (V)	R_2 RESISTOR VALUE (k Ω)
2.0	665
2.5	470
3.0	365
3.3	324
3.4	309
4.0	249
4.5	215
5.0	191

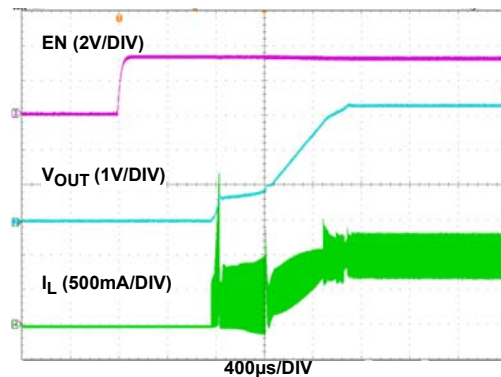

FIGURE 3. START-UP WITH $V_{IN} = 3.6$, $V_{OUT} = 3.3\text{V}$, 1A R_{LOAD}

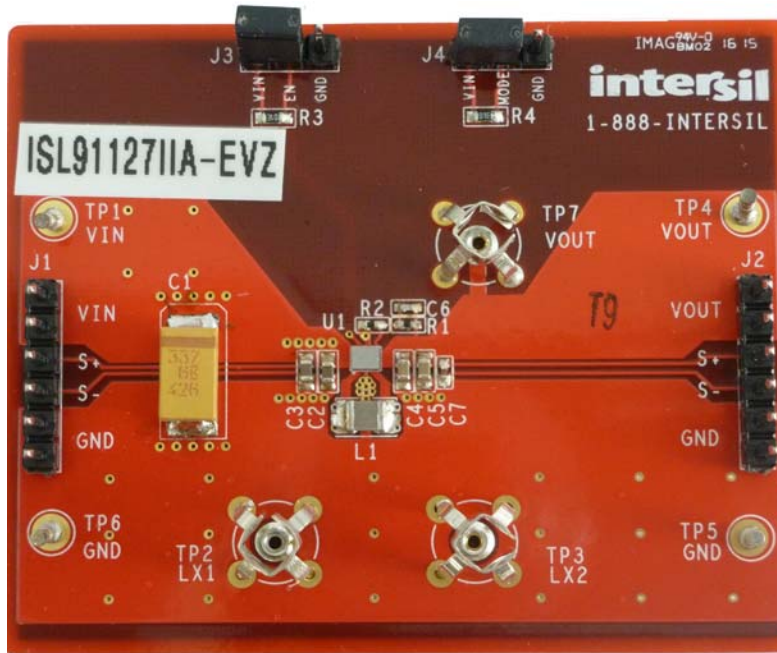

FIGURE 4. ISL91127IIA-EVZ BOARD

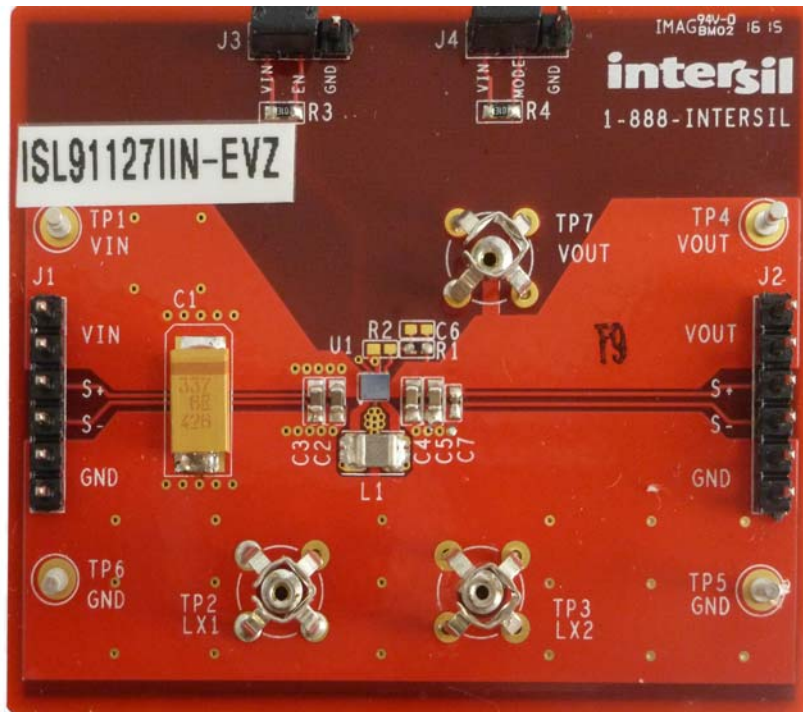

FIGURE 5. ISL91127IIN-EVZ BOARD

ISL91127IIA-EVZ Schematic

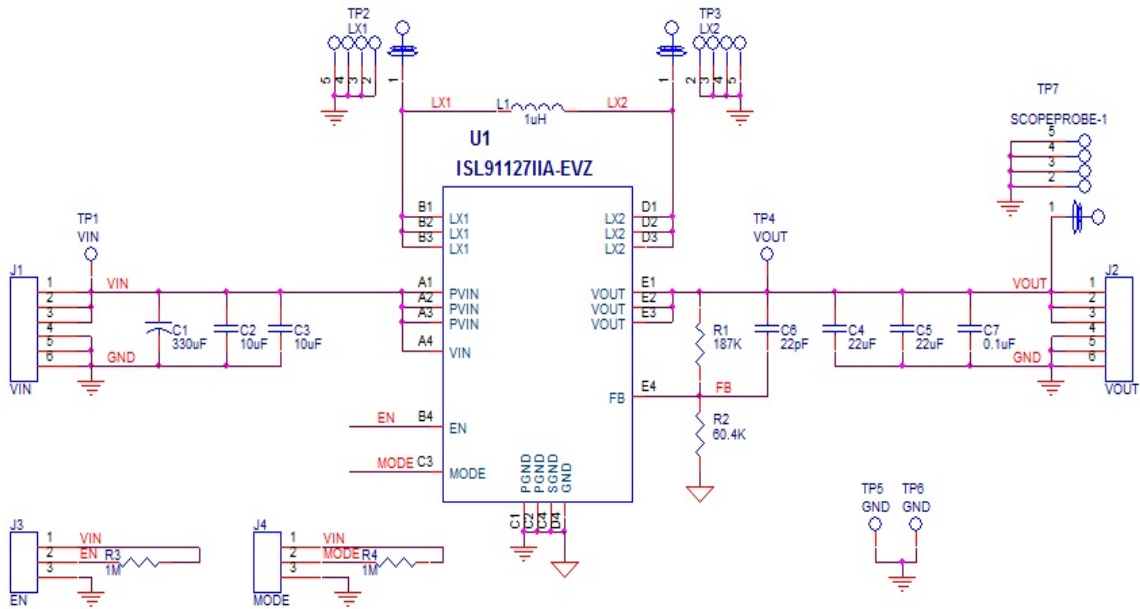

FIGURE 6. ISL91127IIA-EVZ EVALUATION BOARD SCHEMATIC

TABLE 2. ISL91127IIA-EVZ EVALUATION BOARD BILL OF MATERIALS

ITEM#	QTY	DESIGNATORS	PART TYPE	FOOTPRINT	DESCRIPTION	VENDORS
1	1	U1	ISL91127IIAZ	W4x5.20; WLCSF	Intersil ISL91127 Buck-boost Regulator with Adjustable Output Voltage	INTERSIL
2	1	L1	1µH	3.2mmx2.5mmx1.2mm	Power Inductor Toko DFE322512C series, 4.6A (typical), 34m ² (typical)	TOKO
3	1	C1	330µF	7343	Capacitor, Tantalum	ANY
4	2	C2, C3	10µF/6.3V/X5R	0603	Capacitor, Generic	ANY
5	2	C4, C5	22µF/6.3V/X5R	0603	Capacitor, Generic	ANY
6	1	C6	22pF	0402	Capacitor, 22pF 50V 5% NP0 0402	ANY
7	1	C7	0.1µF	0402	Capacitor, Generic	ANY
8	1	R1	187k, 1%	0402	Resistor, Generic	ANY
9	1	R2	60.4k, 1%	0402	Resistor, Generic	ANY
10	2	R3, R4	1M?, 5%	0603	Resistor, Generic	ANY
11	2	J1, J2	HDR-6	HDR-6	Vertical Pin Header, 6-Pin, 0.1" Spacing, Generic	ANY
12	2	J3, J4	HDR-3	HDR-3	Vertical Pin Header, 3-Pin, 0.1" Spacing, Generic	ANY
14	3	TP2, TP3, TP7	SCOPE PROBE	SCOPE PROBE	Test Point, Scope Probe 131-5031-00	TEKTRONIX

ISL91127IIN-EVZ, ISL91127II2A-EVZ Schematic

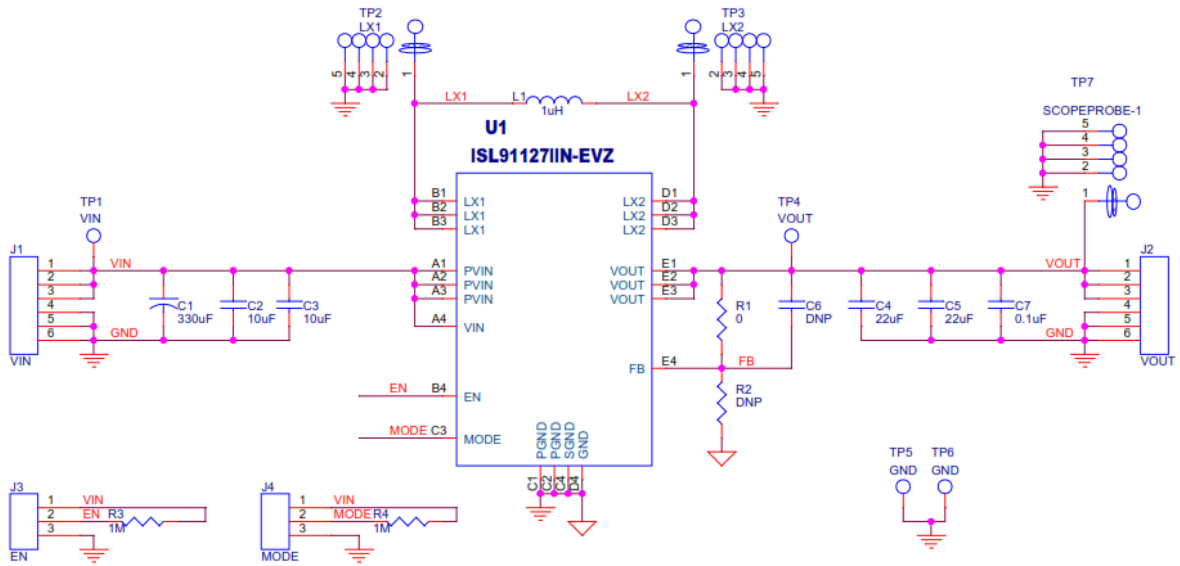

FIGURE 7. ISL91127IIN-EVZ, ISL91127II2A-EVZ EVALUATION BOARD SCHEMATIC

TABLE 3. ISL91127IIN-EVZ, ISL91127II2A-EVZ EVALUATION BOARD BILL OF MATERIALS

ITEM#	QTY	DESIGNATORS	PART TYPE	FOOTPRINT	DESCRIPTION	VENDORS
1	1	U1	ISL91127IINZ, ISL91127II2AZ	W4x5.20; WLCSP	Intersil ISL91127 Buck-boost Regulator	INTERSIL
2	1	L1	1µH	3.2mmx2.5mmx1.2mm	Power Inductor Toko DFE322512C series, 4.6A (typical), 34m ² (typical)	TOKO
3	1	C1	330µF	7343	Capacitor, Tantalum	ANY
4	2	C2, C3	10µF/6.3V/X5R	0603	Capacitor, Generic	ANY
5	2	C4, C5	22µF/6.3V/X5R	0603	Capacitor, Generic	ANY
6	1	C6	DNP	0402		ANY
7	1	C7	0.1µF	0402	Capacitor, Generic	ANY
8	1	R1	0?	0402	Resistor, Generic	ANY
9	1	R2	DNP	0402		ANY
10	2	R3, R4	1M?, 5%	0603	Resistor, Generic	ANY
11	2	J1, J2	HDR-6	HDR-6	Vertical Pin Header, 6-Pin, 0.1" Spacing, Generic	ANY
12	2	J3, J4	HDR-3	HDR-3	Vertical Pin Header, 3-Pin, 0.1" Spacing, Generic	ANY
13	3	TP2, TP3, TP7	SCOPE PROBE	SCOPE PROBE	Test Point, Scope Probe 131-5031-00	TEKTRONIX

PCB Layout

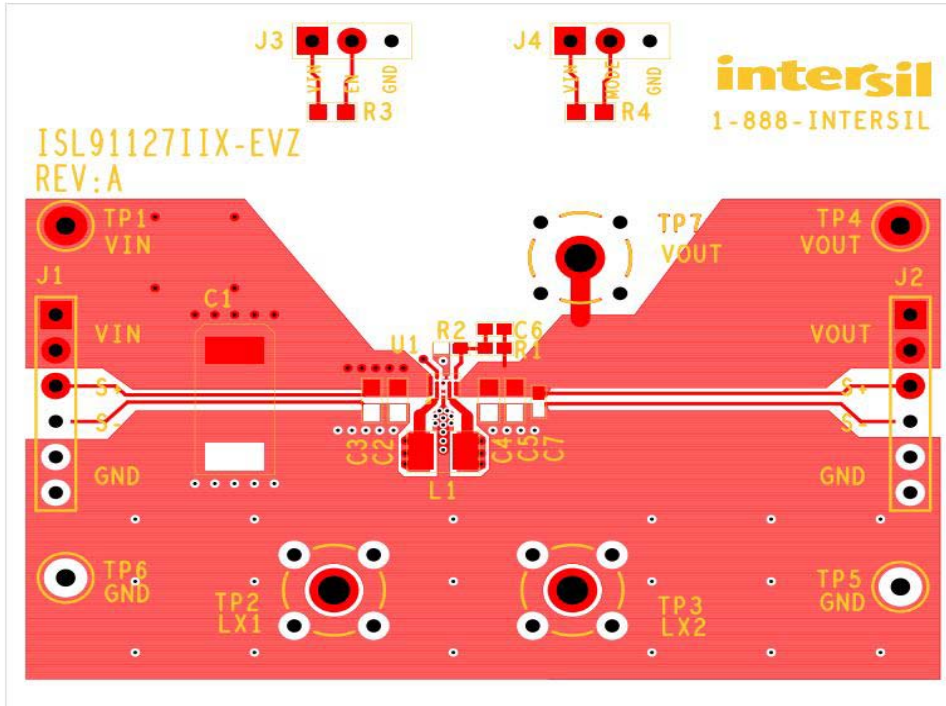

FIGURE 8. TOP LAYER

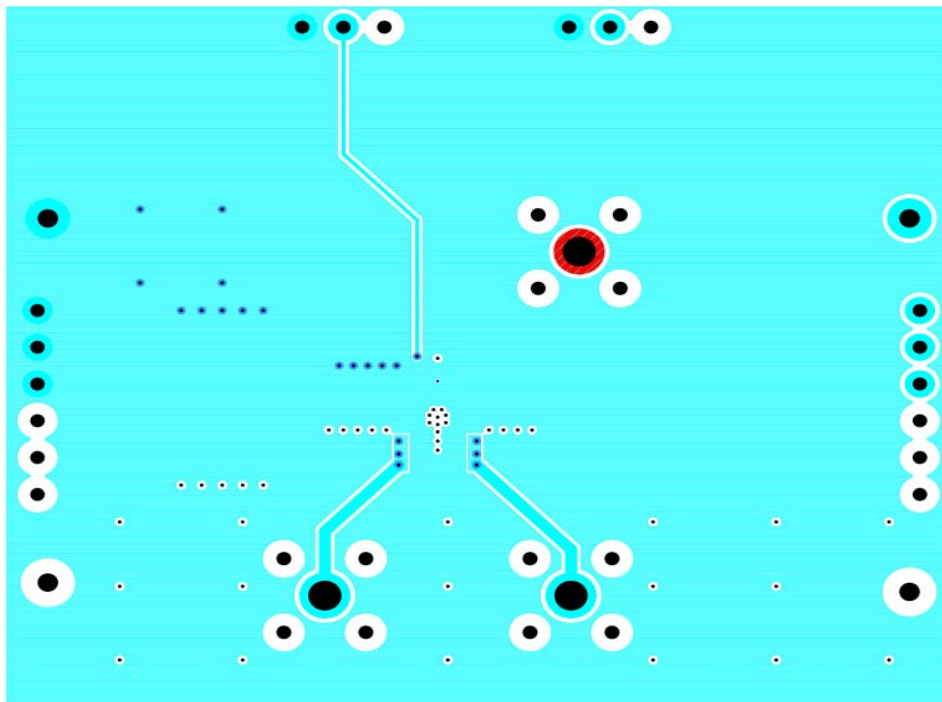

FIGURE 9. INNER LAYER 1

PCB Layout (Continued)

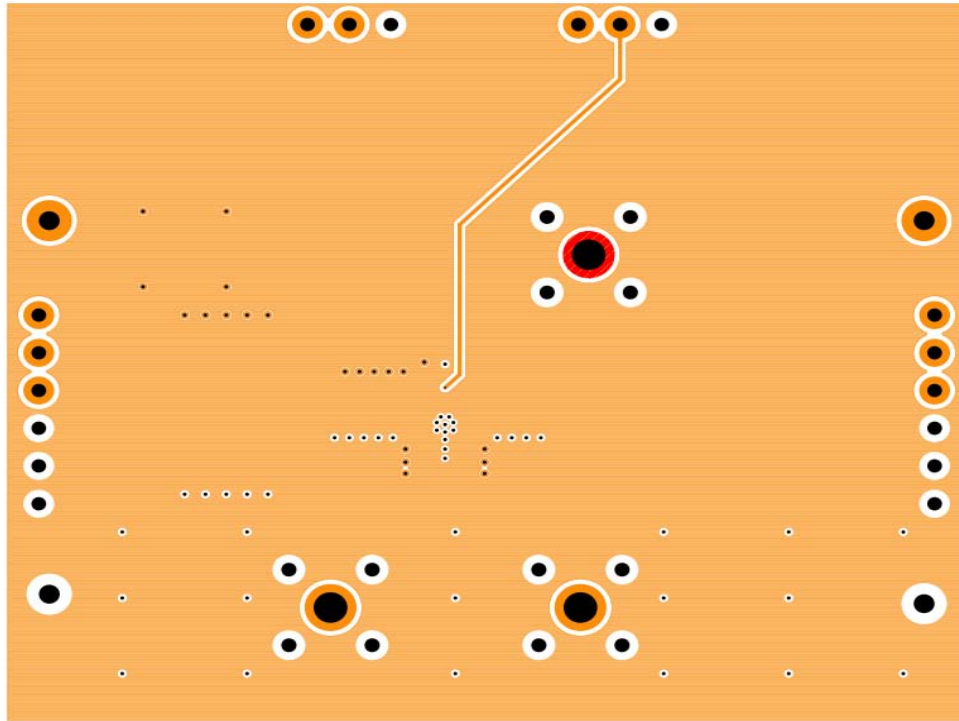

FIGURE 10. INNER LAYER 2

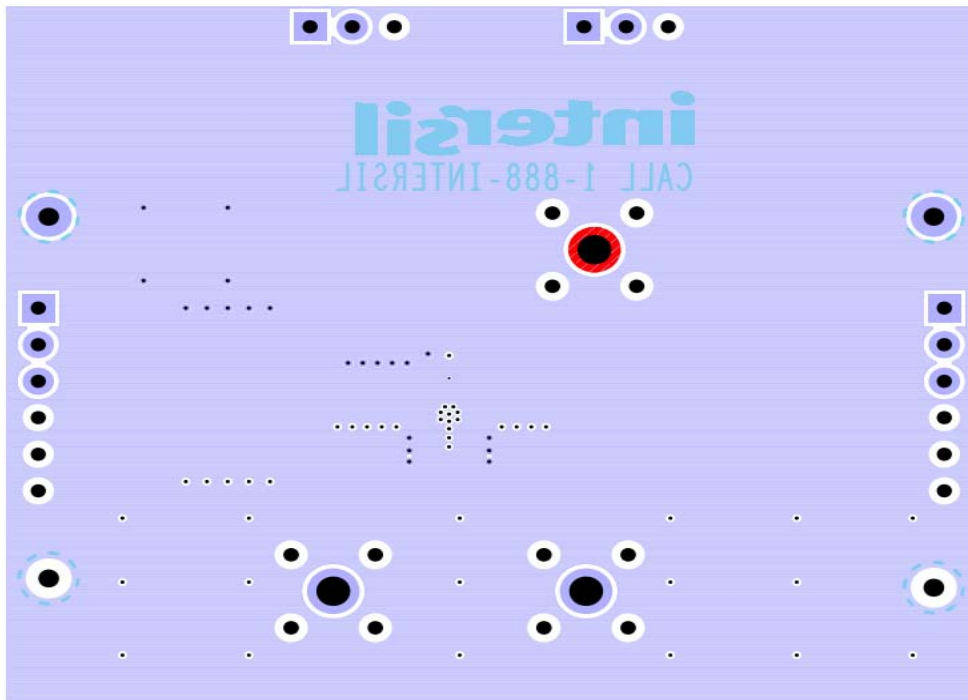

FIGURE 11. BOTTOM LAYER

Typical Performance Curves

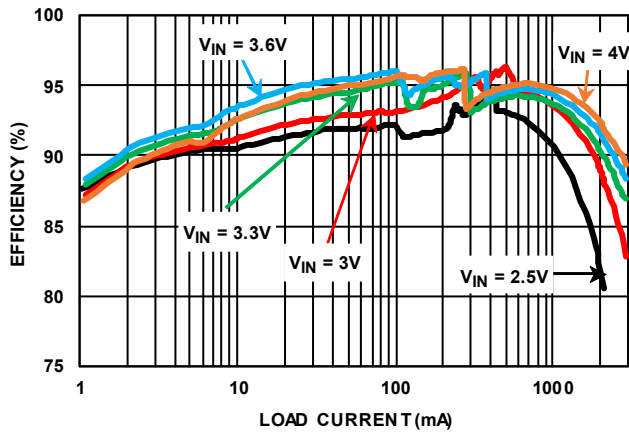

FIGURE 12. EFFICIENCY: $V_{OUT} = 3.3V$

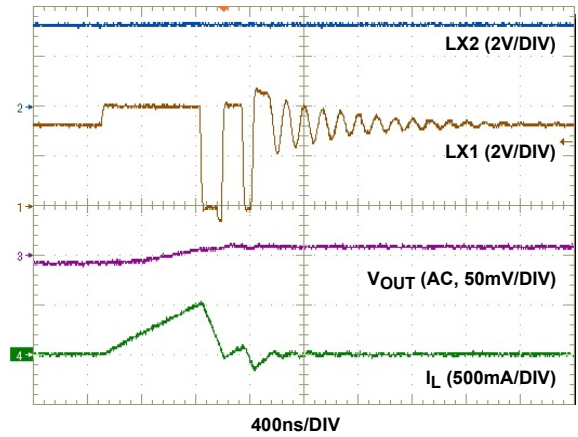

FIGURE 13. STEADY-STATE OPERATION IN PFM ($V_{IN} = 4V$, $V_{OUT} = 3.3V$, NO LOAD)

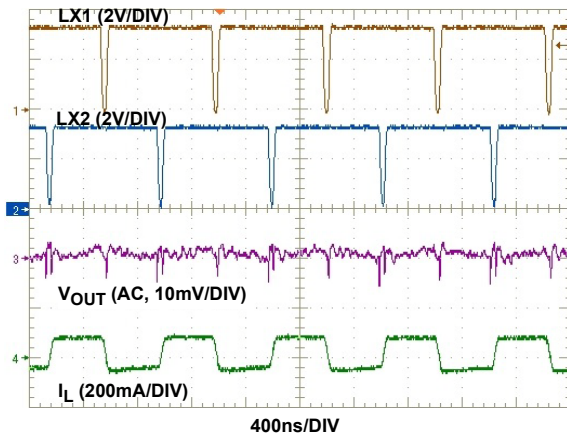

FIGURE 14. STEADY-STATE OPERATION IN PWM ($V_{IN} = 3.3V$, $V_{OUT} = 3.3V$, NO LOAD)

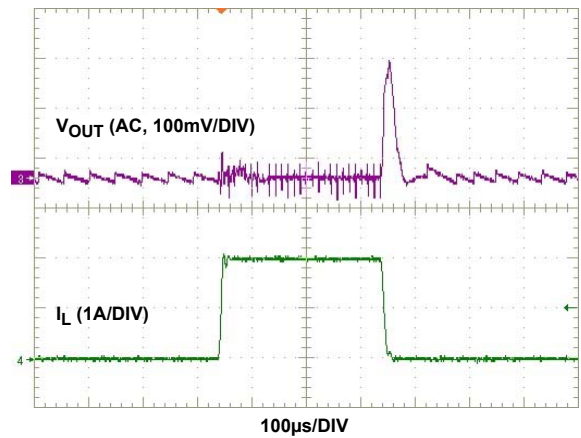

FIGURE 15. 0A TO 2A LOAD TRANSIENT ($V_{IN} = 3.6V$, $V_{OUT} = 3.3V$)