

ISL91133IIX-EVZ

Evaluation Board

AN1958  
Rev 0.00  
September 5, 2014

**Description**

The [ISL91133](#) is an integrated boost with bypass switching regulator for battery powered applications. The device provides a power supply solution for products using one cell Li-ion or Li-polymer battery. The device is capable of delivering up to 2.3A output current from  $V_{IN} = 2.5V$  and  $V_{OUT} = 3.3V$ . The no-load quiescent current is only 108 $\mu A$  in Boost mode and 45 $\mu A$  in Forced Bypass mode, which significantly reduces the standby consumption. The ISL91133 evaluation board allows quick evaluation of the high performance features of this regulator.

**Specifications**

The boards are designed to operate at the following operating conditions:

- Input voltage rating from 2.35V to 5.4V
- Output current: up to 2.3A ( $V_{IN} = 2.5V$ ,  $V_{OUT} = 3.3V$ )
- Forced bypass or Auto Bypass modes with a 38m $\Omega$  switch
- PFM mode at light-load currents
- 108 $\mu A$  quiescent current minimizes standby consumption in Boost mode
- 2.5MHz switching frequency

**Key Features**

- Jumper selectable EN (Enabled/Disabled)
- Jumper selectable  $\overline{BYP}$ S (Auto/Forced)
- Jumper selectable VSET (No offset/offset on  $V_{OUT}$ )
- Connectors, test points, and jumpers for easy probing

**Related Literature**

For a full list of related documents, visit our website

- [ISL91133](#) device page

**Ordering Information**

EVALUATION BOARD NUMBER	$V_{OUT}$ OPTION
ISL91133IIL-EVZ	3.15/3.3V (VSET L/H)
ISL91133IIM-EVZ	3.3/3.5V (VSET L/H)
ISL91133IIN-EVZ	3.5/3.7V (VSET L/H)
ISL91133IIO-EVZ	3.7/3.77V (VSET L/H)
ISL91133IIP-EVZ	4.5/4.76V (VSET L/H)
ISL91133IIQ-EVZ	5.0/5.2V (VSET L/H)

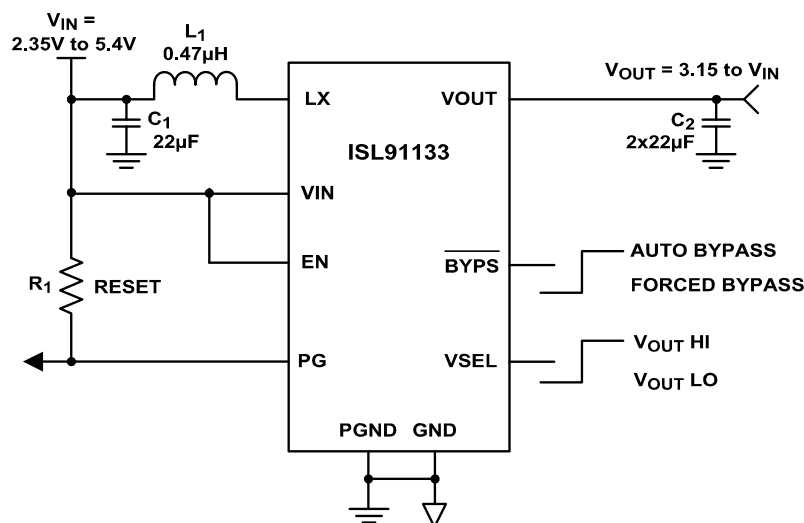

FIGURE 1. ISL91133 TYPICAL APPLICATION SCHEMATIC

## Functional Description

The ISL91133 implements a complete boost switching regulator, with PWM controller, internal switches, references, protection circuitry, and bypass control. The ISL91133 is designed to support six fixed output voltage options. A voltage select pin (VSET) is available to scale up the output voltage by a small offset to compensate the load transient droop. The evaluation boards have been functionally optimized for best performance of the ISL91133. This part requires only an inductor and a few external components to operate. The 2.5MHz switching frequency further reduces the size of external components. The input power and load connections are provided through multi-pin connectors for high current operations.

The ISL91133 evaluation board is shown in [Figures 3 and 4](#). The board's enable function is controlled by the on-board jumper header J3. Similarly, the VSET function is controlled by the on-board jumper header J4, and the BYPASS function can be set to Forced or Auto mode by controlling the on-board jumper header J5.

The schematic of the ISL91133IIM-EVZ evaluation board is shown on [page 4](#). The PCB layout images for all layers are shown in [Figures 5 and 6](#). The bill of materials of the ISL91133IIX-EVZ is shown in [Table 1 on page 4](#).

## Operating Range

The  $V_{IN}$  range of the boards is 2.35V to 5.4V. The  $V_{OUT}$  for the ISL91133 can range from 3.15V to 5.2V. The  $I_{OUT}$  range of the boards is 0 to 2.3A. The operating ambient temperature range is  $-40^{\circ}\text{C}$  to  $+85^{\circ}\text{C}$ .

## Quick Start Guide

For the ISL91133 board, the default output can be selected based on [Table 1](#).

Refer to the following Quick Setup Guide to configure and power-up the board for proper operation. During the power-on process, the expected waveforms are shown in [Figure 2](#).

## Quick Setup Guide

1. Install jumpers on J3 shorting EN to VIN.
2. Install jumper on J5 shorting  $\overline{\text{BYP}}$  to VIN, Auto Bypass mode.
3. Install jumper on J4 shorting VSET to GND or leave it as NC.
4. Connect power supply to J1, with voltage setting between 2.35V and 5.4V.
5. Connect electronic load to J2.
6. Place scope probes on VOUT test point, and other test points of interest.
7. Turn on the power supply.
8. Monitor the output voltage (refer to ordering information) when  $V_{IN} < V_{OUT}$  (Boost mode),  $V_{IN} = V_{OUT}$  when  $V_{IN} > V_{OUT}$   $1.015 * V_{OUT}$  (Bypass mode), the supply current should be  $\sim 110\mu\text{A}$  (Boost mode) and  $\sim 95\mu\text{A}$  (Auto Bypass mode). In Forced Bypass mode ( $\overline{\text{BYP}}$  pin = GND), supply current should be  $\sim 45\mu\text{A}$ .
9. Turn on the electronic load.

10. Measure the output voltage with the voltmeter. The voltage should regulate within datasheet specification limits.
11. To determine efficiency, measure input and output voltages at the test points J1 and TP3. The bench power supply can be connected to the PVIN and GND headers on J1. The electronic load can be connected to the  $V_{OUT}$  and GND headers on J2. Measure the input and output currents and calculate efficiency based on these measurements.

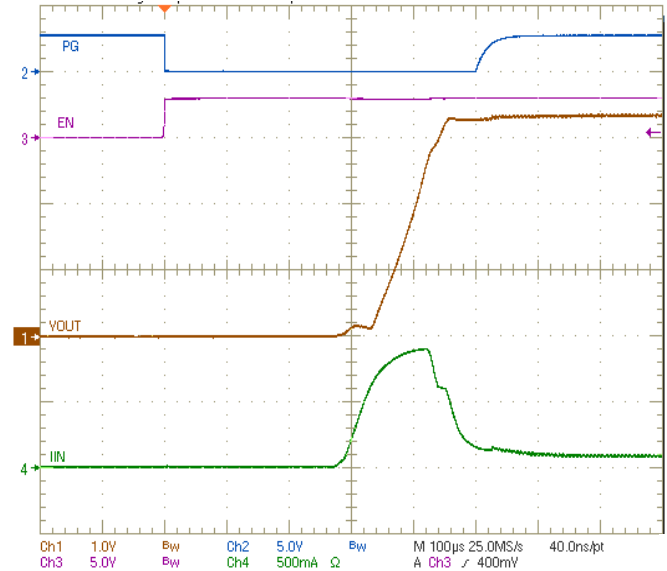

FIGURE 2. START-UP WAVEFORM 50Ω LOAD

## Layout Considerations

1.  $C_1$  is used to compensate for line drops on cables from the power supply to the IC, this is not required for the actual board design.
2. Place the input capacitor ( $C_2$ ) close to the IC to reduce  $V_{IN}$  spikes/noise.
3. Place the output capacitors ( $C_3$ ,  $C_4$ ) as close as possible to the IC to minimize  $V_{OUT}$  spikes.
4. Connect the boost inductor ( $L_1$ ) between VIN and LX using short and wide traces. It is recommended to use multiple vias between the LX pin and the inductor. Three vias of 7 mils width were used on the evaluation board.
5. Renesas recommends maximizing the copper pour area for VIN, VOUT, and GND for better thermal performance.
6. Connect AGND and PGND of the IC to each other. It is crucial to connect these two grounds at a location very close to the IC.

# ISL91133 Evaluation Board



FIGURE 3. TOP VIEW

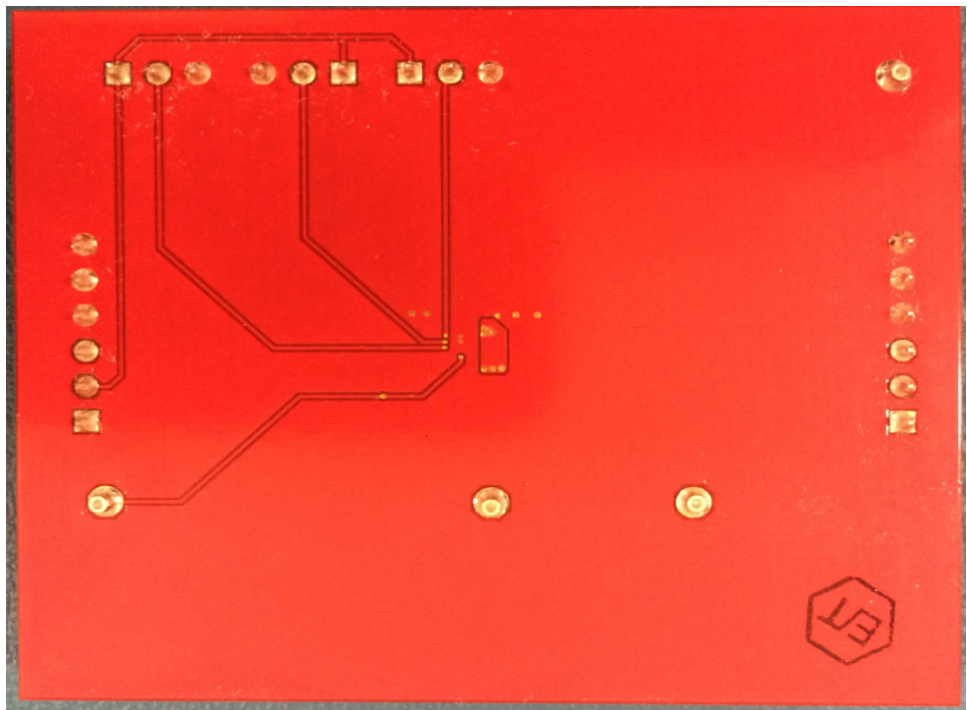

FIGURE 4. BOTTOM VIEW

# ISL91133 Evaluation Board Schematic

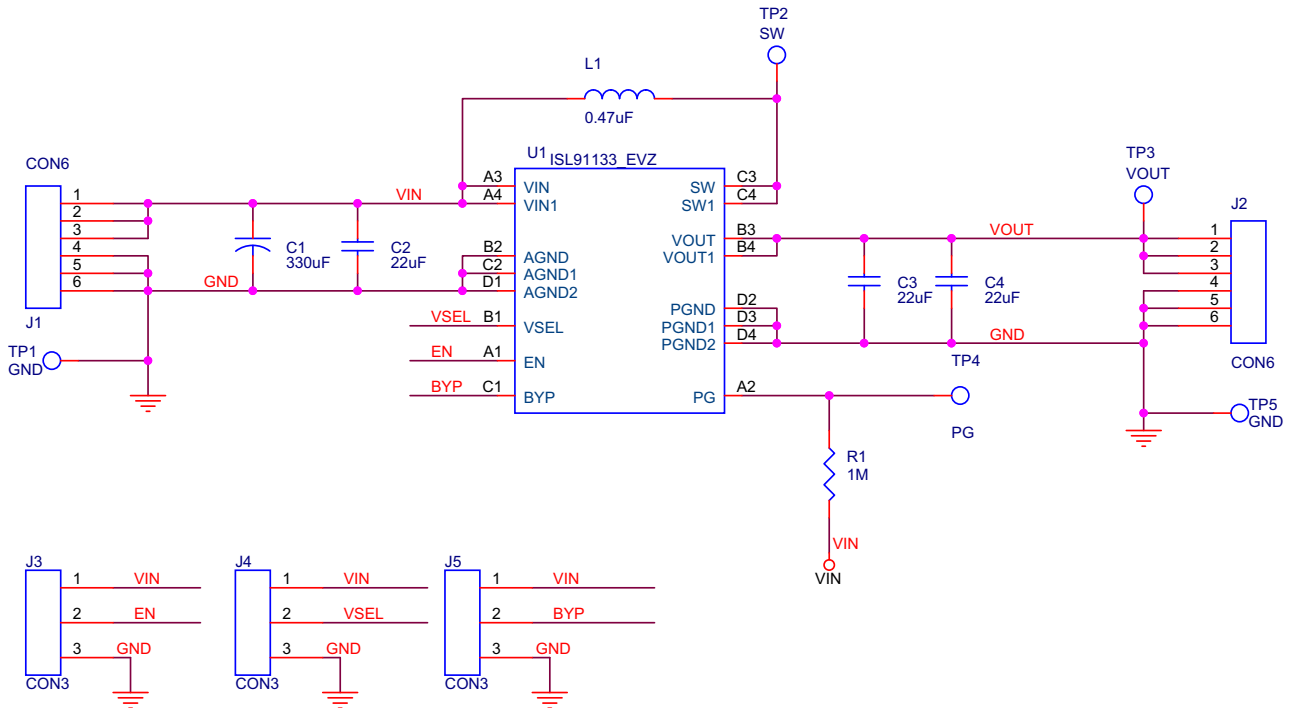

TABLE 1. ISL91133 EVALUATION BOARD BILL OF MATERIALS

ITEM#	QTY	DESIGNATORS	PART TYPE	FOOTPRINT	DESCRIPTION	VENDORS
1	1	U1	ISL91133	W4x4.16E WLCSP	Renesas ISL91133 Boost with Bypass Regulator	Renesas
2	1	L1	0.47µH	3.2x2.5mm	PIFE32251B-R47MS-39	Cyntec
3	1	C1	330µF/6.3V/X5R	7343	T491D337K006AT	Kemet
4	3	C2, C3, C4	22µF/6.3V/X5R	0603	GRM188R61A226M	ANY
5	1	R1	1MΩ, 1%	0603	Resistor, Generic	ANY
6	2	J1, J2	HDR-6	HDR-6	Vert. Pin Header, 6-Pin, 0.1" Spacing, Generic	FCI
7	3	J3, J4, J5	HDR-3	HDR-3	Vert. Pin Header, 3-Pin, 0.1" Spacing, Generic	FCI
8	4	TP1, TP2, TP3, TP4	TEST POINT	TEST POINT	Test Point, 1514-2	KEYSTONE

# PCB Layout

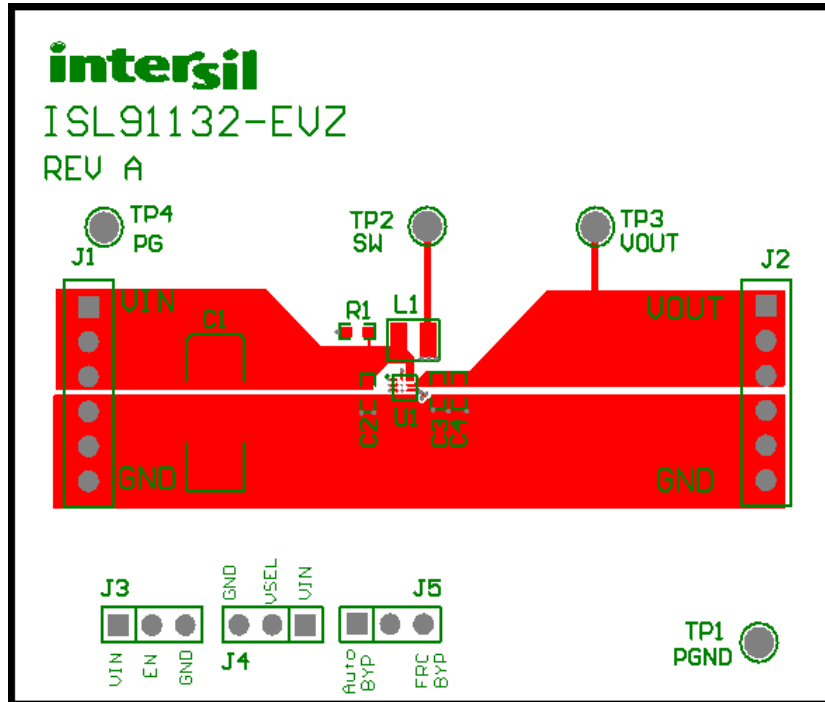

FIGURE 5. TOP LAYER (RECOMMEND USING ISL91132 LAYOUT PLAN FOR ISL91133)

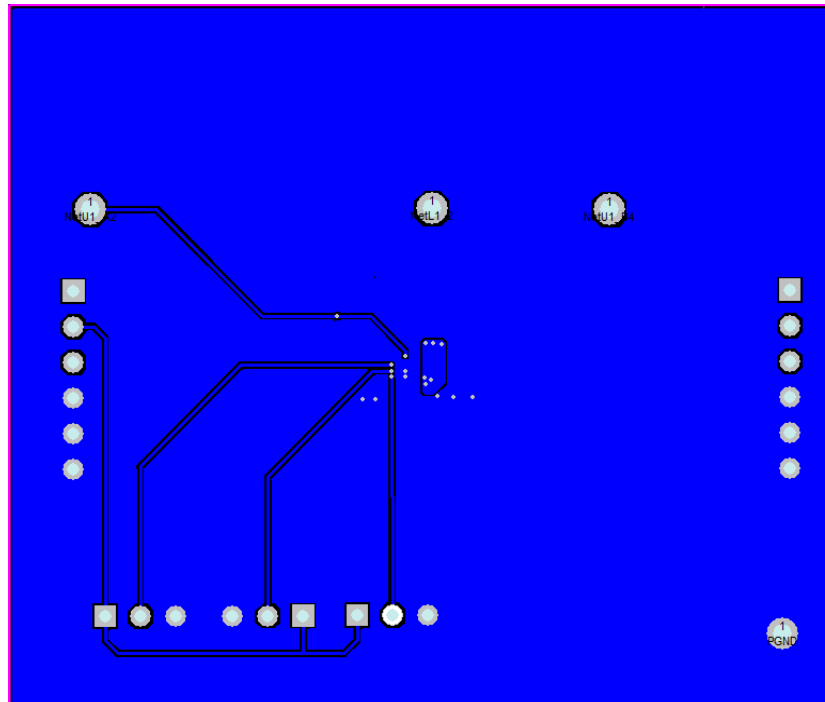

FIGURE 6. BOTTOM LAYER 1

## Typical Performance Curves

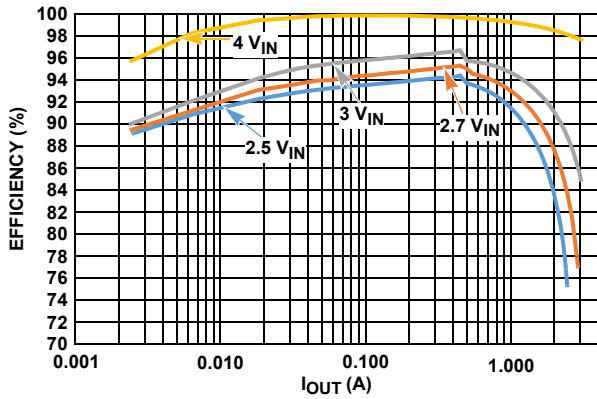

FIGURE 7. EFFICIENCY vs LOAD CURRENT,  $V_{OUT} = 3.3V$

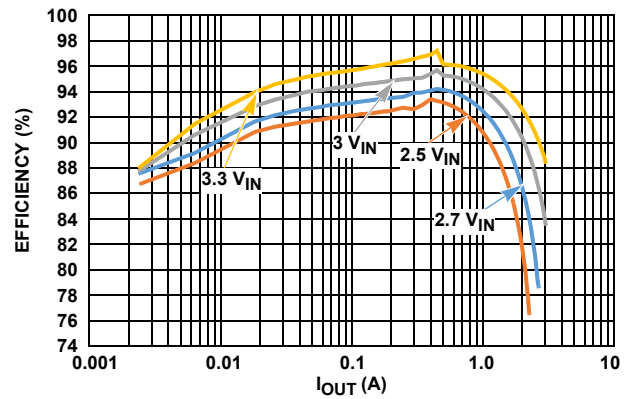

FIGURE 8. EFFICIENCY vs LOAD CURRENT,  $V_{OUT} = 3.5V$

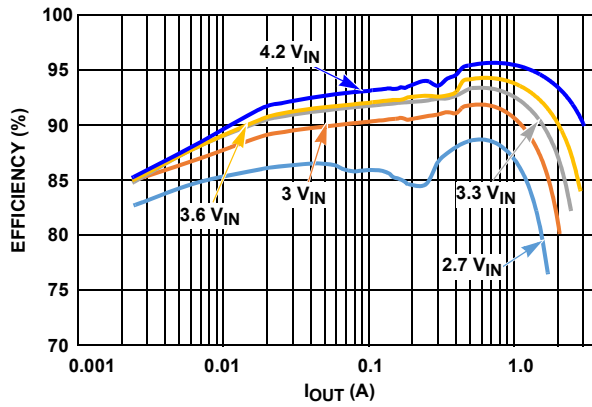

FIGURE 9. EFFICIENCY vs LOAD CURRENT,  $V_{OUT} = 5V$