

ISL9113ERxZ-EVZ

Evaluation Board

AN1816
Rev 1.00
Oct 26, 2016

Description

The [ISL9113](#) provides a power supply solution for devices powered by 3-cell alkaline, NiCd, NiMH, or 1-cell Li-Ion/Li-Polymer batteries. It uses Intersil's proprietary boost algorithm to maintain voltage regulation when the input voltage is very low.

Specifications

The boards are designed to operate at the following operating conditions:

- Input voltage rating from 0.8V to 4.7V
- Fixed 5V nominal output voltage on the ISL9113ER7Z-EVZ
- Adjustable output voltage on the ISL9113ERAZ-EVZ
- Up to 500mA output current ($V_{BAT} = 3V, V_{OUT} = 5V$)
- 1.8MHz switching frequency
- Operating temperature range: $-20^{\circ}C$ to $+85^{\circ}C$

Key Features

- Small, compact design
- Jumper selectable EN (enabled/disabled)
- On-board LED fault indication (for ISL9113ER7Z-EVZ)
- Connectors, test points, and jumpers for easy probing

Related Literature

- For a full list of related documents please visit our website - [ISL9113](#) product page

Ordering Information

PART NUMBER	DESCRIPTION
ISL9113ER7Z-EVZ	Evaluation Board for ISL9113ER7Z
ISL9113ERAZ-EVZ	Evaluation Board for ISL9113ERAZ

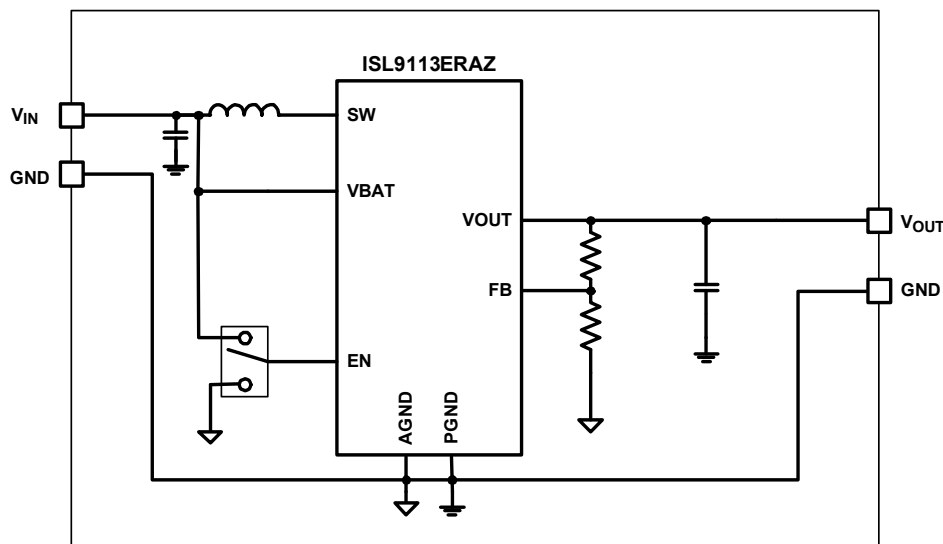

FIGURE 1. ISL9113ERAZ-EVZ BLOCK DIAGRAM

Functional Description

The ISL9113ERAZ-EVZ and ISL9113ER7Z-EVZ provide simple platforms to evaluate the features of the ISL9113 boost regulator. The ISL9113ER7Z-EVZ is for the fixed 5V output ISL9113ER7Z IC and the ISL9113ERAZ-EVZ is for the adjustable output ISL9113ERAZ IC. The evaluation boards have been functionally optimized for best performance of the ISL9113 IC series. Input power and load connections are provided through multiple pin connectors for high current operations.

The evaluation board image is shown in [Figures 3 and 4](#) on [page 3](#). The same PCB is used for both ISL9113ERAZ-EVZ and ISL9113ER7Z-EVZ boards with different BOM's. The board's enable function is controlled by the on-board jumper header J2.

The schematic for the ISL9113ERAZ-EVZ is shown on [Figure 5](#) on [page 4](#) and ISL9113ER7Z-EVZ is shown in [Figure 6](#) on [page 4](#). The PCB layout images for all layers are shown in [Figures 7 and 8](#) on [page 6](#). The bill of materials of the ISL9113ERAZ-EVZ and ISL9113ER7Z-EVZ are shown in [Tables 1 and 2](#) on [page 5](#).

Operating Range

The V_{IN} range of the boards is 0.8V to 4.7V. The I_{OUT} range of the boards is 0 to 500mA. The operating ambient temperature range is -20°C to +85°C.

Recommended PCB Layout

Correct PCB layout is critical for proper operation of the ISL9113. The input and output capacitors should be positioned as closely to the IC as possible. The ground connections of the input and output capacitors should be kept as short as possible, and should be on the component layer to avoid problems that are caused by high switching currents flowing through PCB vias.

Quick Start Guide

Refer to the following Quick Setup Guide to configure and power-up the board for proper operation. During the power-on process, the expected waveforms are shown in [Figure 2](#).

Setup ISL9113ERA-EVZ

1. Install jumper on J2, shorting EN to VIN.
2. Connect a power supply to J1, with voltage setting between 0.8V and 4.7V.
3. Connect electronic load to J3.
4. Place scope probes on VOUT test point and other test points of interest.
5. Turn on the power supply.
6. Monitor the output voltage start-up sequence on the scope. The waveforms will look similar to that shown in [Figure 2](#).
7. Turn on the electronic load.
8. Measure the output voltage with the voltmeter. The voltage should regulate within datasheet specification limits.

Additional Step for ISL9113ER7Z-EVZ Setup

1. Follow Steps 1 through 8 for the ISL9113ERAZ-EVZ setup.
2. Create a fault condition as described in "FAULT DETECTION AND RESPONSE" table of the [ISL9113](#) datasheet. The LED should be ON when a fault condition occurs.

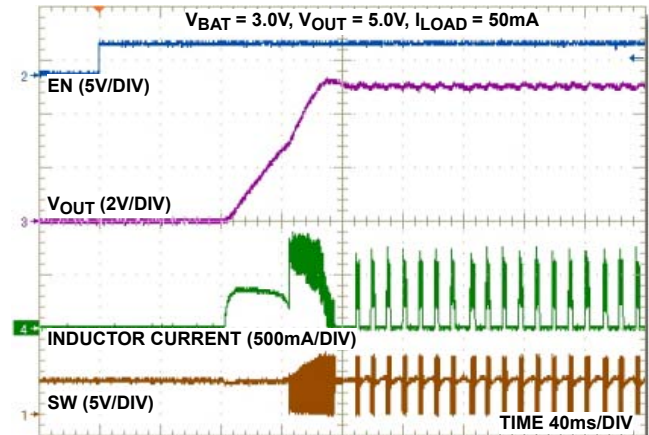

FIGURE 2. START-UP WITH $V_{IN} = 3V$ AND $V_{OUT} = 5V$, 50mA LOAD

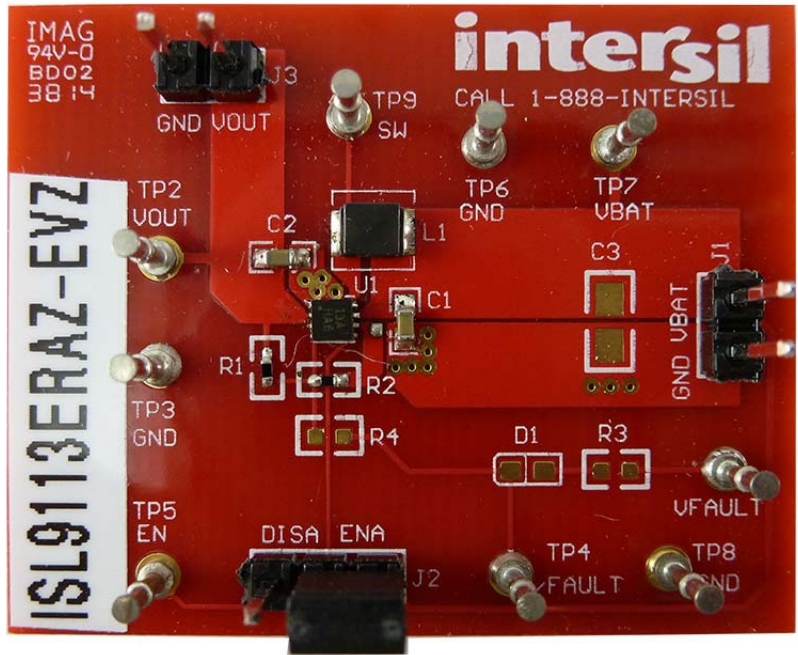

FIGURE 3. ISL9113ERAZ-EVZ BOARD TOP VIEW

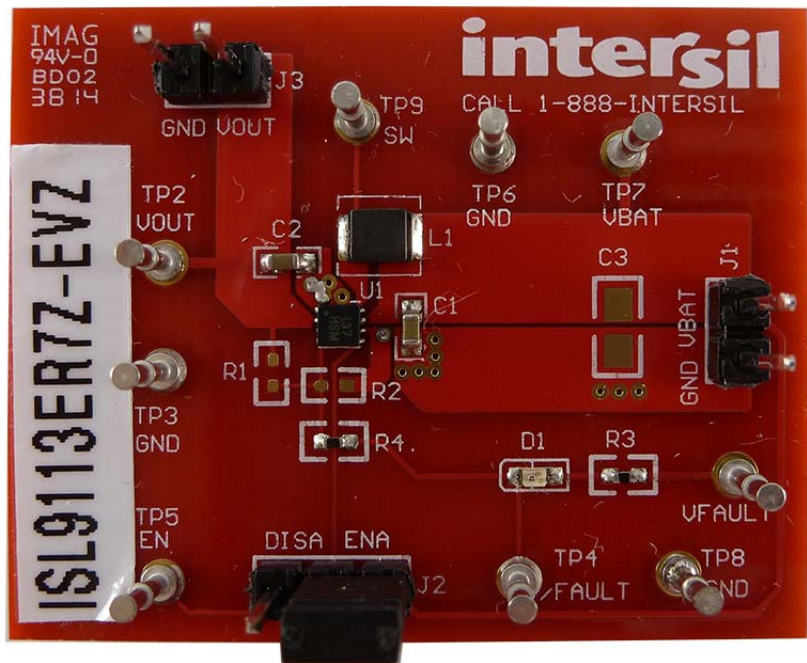

FIGURE 4. ISL9113ER7Z-EVZ BOARD TOP VIEW

ISL9113ERAZ-EVZ, ISL9113ER7Z-EVZ Schematics

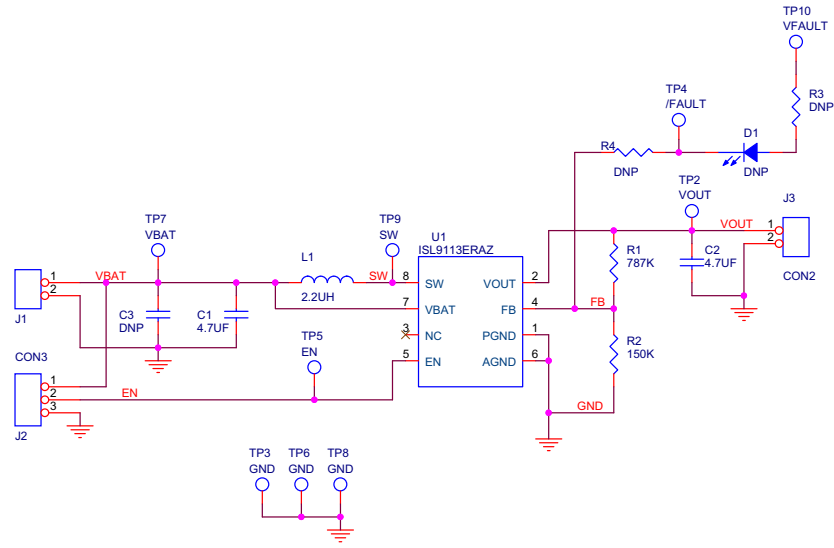

FIGURE 5. ISL9113ERAZ-EVZ EVALUATION BOARD SCHEMATIC

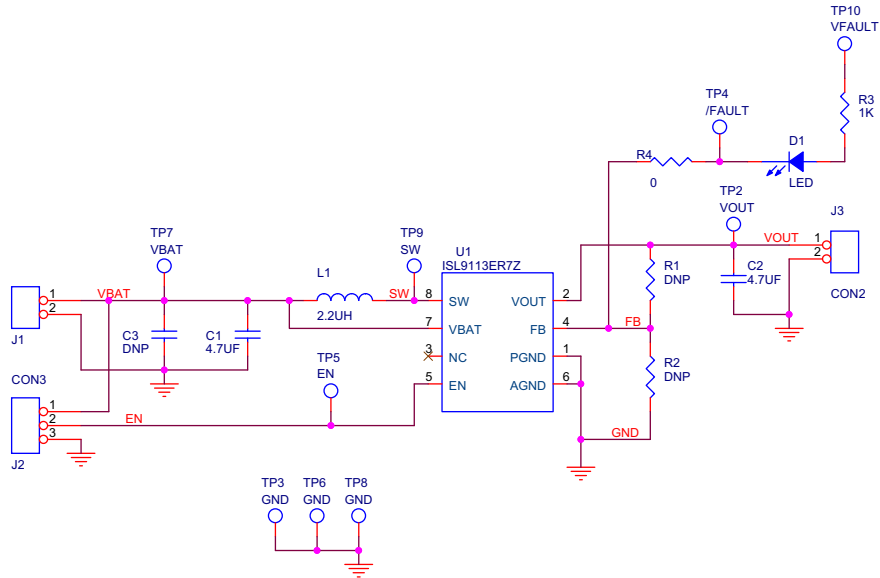

FIGURE 6. ISL9113ER7Z-EVZ EVALUATION BOARD SCHEMATIC

TABLE 1. ISL9113ERAZ-EVZ EVALUATION BOARD BILL OF MATERIALS

ITEM#	QTY	DESIGNATORS	VALUE	PART NUMBER	FOOTPRINT	DESCRIPTION	VENDORS
1	1	U1	-	ISL9113ERAZ	8LD 2x2mm DFN	Boost Regulator	Intersil
2	1	L1	2.2 μ H	LQH32PN2R2NNO	1210	Inductor, 1600mA, \pm 30%	Murata
3	2	C1, C2	4.7 μ F	GRM188F51A475ZE20D	0603	Capacitor Ceramic, Y5V, 10V, \pm 10%	Murata
4	1	C3	DNP				
5	2	R4	DNP				
6	1	R3	DNP				
7	1	D1	DNP				
8	1	R1	787k Ω	CRCW0402787KFKTD	0402	Resistor, 1/16W, 1%	Vishay Dale
9	1	R2	150k Ω	RC0402FR-07150KL	0402	Resistor, 1/16W, 1%	Yageo
10	9	TP2, TP3, TP4, TP5, TP6, TP7, TP8, TP9, TP10	Power Post			Connectors	Any
11	2	JP1, JP3	Jumper header		HDR-2		Any
12	1	JP2	Jumper header		HDR-3		Any

TABLE 2. ISL9113ER7Z-EVZ EVALUATION BOARD BILL OF MATERIALS

ITEM#	QTY	DESIGNATORS	VALUE	PART NUMBER	FOOTPRINT	DESCRIPTION	VENDORS
1	1	U1	-	ISL9113ER7Z	8L 2x2mm DFN	Boost Regulator	Intersil
2	1	L1	2.2 μ H	LQH32PN2R2NNO	1210	Inductor, 1600mA, \pm 30%	Murata
3	2	C1, C2	4.7 μ F	GRM188F51A475ZE20D	0603	Capacitor Ceramic, Y5V, 10V, \pm 10%	Murata
4	1	C3	DNP	-	0805		-
5	1	R3	1k Ω	CR0603-16W-1001FT	0603	Resistor, Generic	Venkel
6	1	R4	0 Ω	ERJ-2GE0R00X	0603	Resistor, Generic	Panasonic
7	1	D1	LED	160-1181-1-ND	0603	LED, RED, SMD	Lite-On
8	1	R1	DNP				
6	1	R2	DNP				
9	9	TP2, TP3, TP4, TP5, TP6, TP7, TP8, TP9, TP10	Power Post			Test point	Any
10	2	JP1, JP3	Jumper header		HDR-2	Connector	Any
11	1	JP2	Jumper header		HDR-3	Connector	Any

PCB Layout

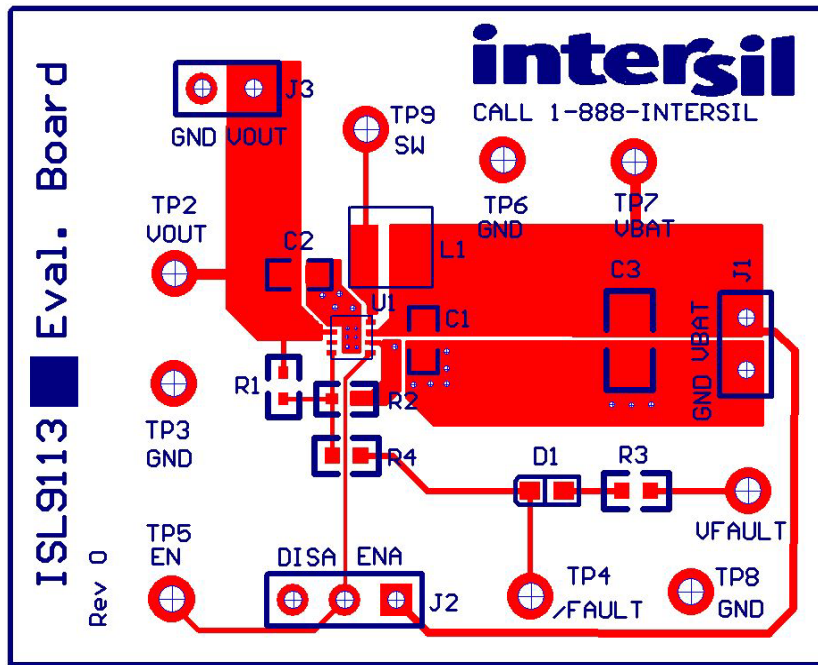

FIGURE 7. TOP LAYER

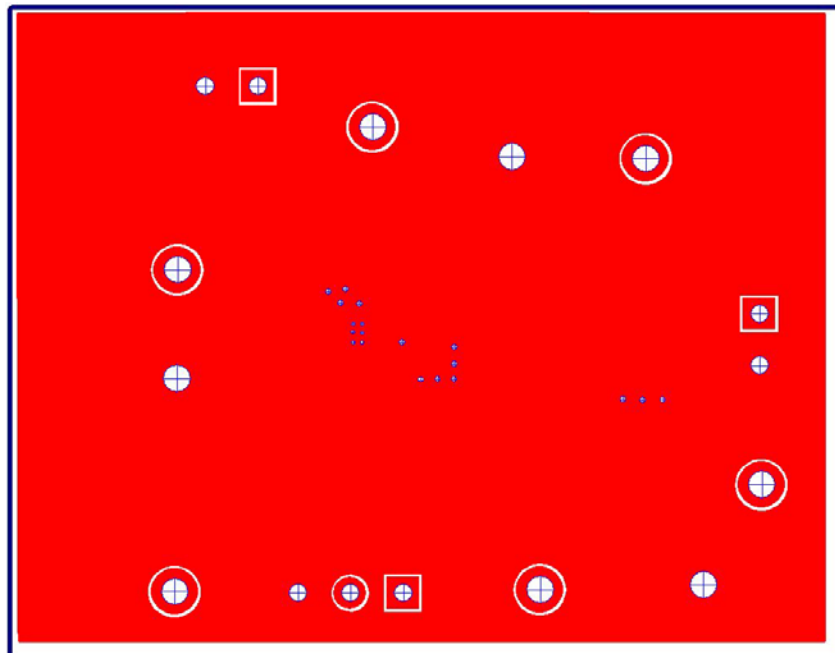

FIGURE 8. BOTTOM LAYER

Typical Performance Curves

Unless otherwise noted, operating conditions are: $T_A = +25^\circ\text{C}$, $V_{IN} = EN = 3.6\text{V}$,

$L_1 = 2.2\mu\text{H}$, $C_1 = 4.7\mu\text{F}$, $C_2 = 4.7\mu\text{F}$, $V_{OUT} = 5\text{V}$, $I_{OUT} = 0\text{A}$ to 1A

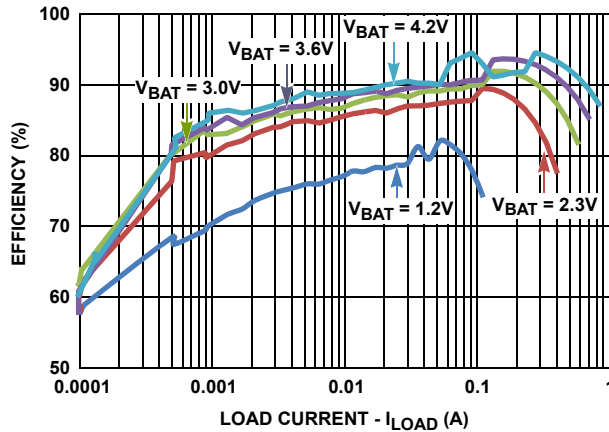

FIGURE 9. EFFICIENCY ($V_{OUT} = 5\text{V}$)

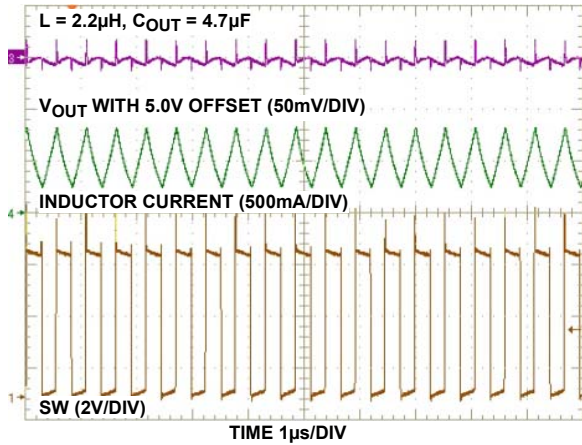

FIGURE 10. STEADY-STATE OPERATION IN PWM ($V_{IN} = 3\text{V}$, $V_{OUT} = 5\text{V}$, 250mA LOAD)

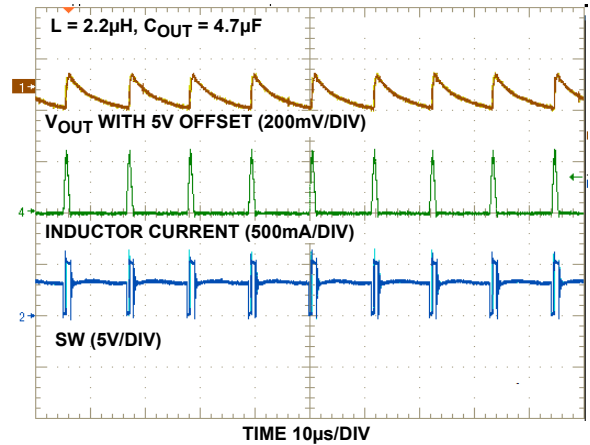

FIGURE 11. STEADY-STATE OPERATION IN PFM ($V_{IN} = 3\text{V}$, $V_{OUT} = 5\text{V}$, 20mA LOAD)

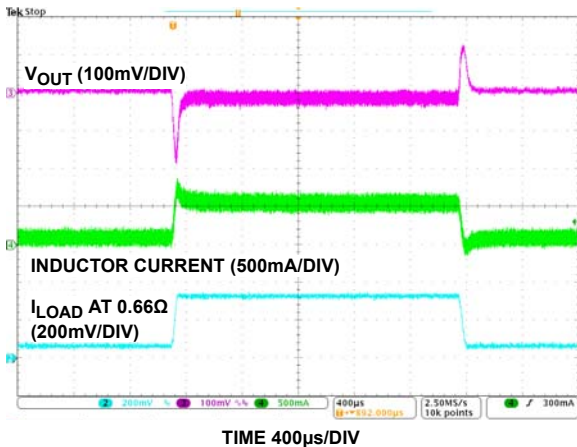

FIGURE 12. 100mA TO 500mA LOAD TRANSIENT ($V_{IN} = 3.6\text{V}$, $V_{OUT} = 5\text{V}$)

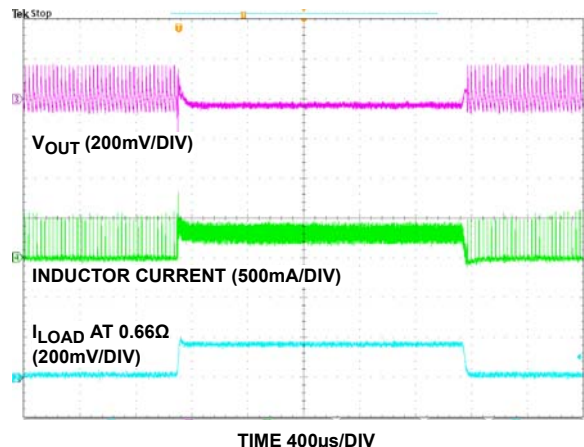

FIGURE 13. 20mA TO 250mA LOAD TRANSIENT ($V_{IN} = 3.6\text{V}$, $V_{OUT} = 5\text{V}$)