

ISL9120IRx-EVZ

Evaluation Board

UG042
Rev 0.00
July 17, 2015

Description

The [ISL9120IR](#) is a highly integrated buck-boost switching regulator for systems using new battery chemistries. It uses Intersil's proprietary buck-boost algorithm to maintain voltage regulation, while providing excellent efficiency and very low output voltage ripple when the input voltage is close to the output voltage. The ISL9120IRx-EVZ platforms allow quick evaluation of the high performance features of the ISL9120IR buck-boost regulator series.

Specifications

The boards are designed to operate under the following conditions:

- Input voltage range of 1.8V to 5.5V
- Resistor programmable output voltage on the ISL9120IRA-EVZ
- Fixed 3.3V output voltage on the ISL9120IRN-EVZ
- Up to 800mA output current ($V_{IN} = 2.5V, V_{OUT} = 3.3V$)
- Operating temperature range: $-40^{\circ}C$ to $+85^{\circ}C$

Key Features

- Small, compact design
- Jumper selectable EN (enabled/disabled)
- Jumper selectable BYP (buck-boost/forced bypass)
- Connectors, test points and jumpers for easy probing

References

- [ISL9120IR](#) Datasheet

Ordering Information

PART NUMBER	DESCRIPTION
ISL9120IRN-EVZ	Evaluation board for ISL9120IRNZ, fixed 3.3V output
ISL9120IRA-EVZ	Evaluation board for ISL9120IRAZ, adjustable output

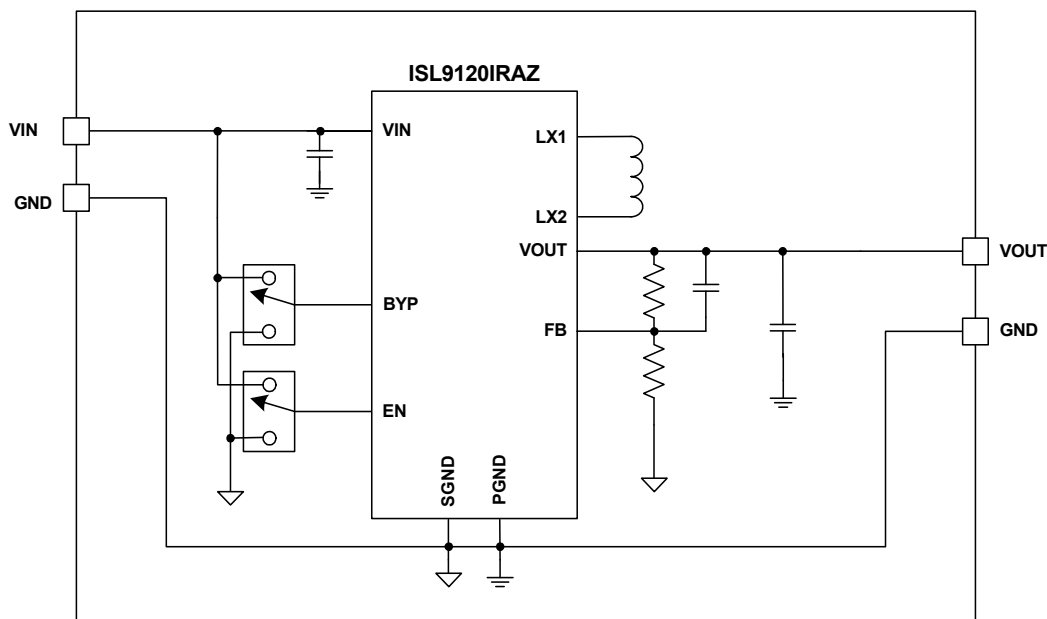

FIGURE 1. ISL9120IRA-EVZ BLOCK DIAGRAM

Functional Description

The ISL9120IRx-EVZ evaluation boards provide simple platforms to demonstrate the features of the ISL9120IR buck-boost regulator. The ISL9120IRN-EVZ is for the fixed 3.3V output IC ISL9120IRNZ. The ISL9120IRA-EVZ is for the adjustable output IC ISL9120IRAZ. The evaluation boards have been functionally optimized for best performance of the ISL9120IR IC series. The input power and load connections are provided through multipin connectors for high current operations.

The ISL9120IRA-EVZ evaluation board schematic is shown in [Figure 5, on page 3](#). The board's enable function is controlled by the on-board jumper header J3. Similarly, the forced bypass function is controlled by the on-board jumper header J4. The schematic for the ISL9120IRN-EVZ is shown in [Figure 7, on page 5](#). The PCB layout images for all layers are shown in [Figures 8 and 9 on page 6](#). The bill of materials for the ISL9120IRA-EVZ is shown in [Table 2 on page 4](#). The bill of materials for the ISL9120IRN-EVZ is shown in [Table 3 on page 5](#).

Operating Range

The V_{IN} range of the boards is 1.8V to 5.5V. The V_{OUT} range for the ISL9120IRA-EVZ is 2V to 5V. The I_{OUT} range of the boards is 0 to 1A. The operating ambient temperature range is -40°C to $+85^{\circ}\text{C}$.

Quick Start Guide

For the ISL9120IRA-EVZ board, the default output voltage is set at 3.3V. Should other output voltages be desired, resistor R_2 can be changed to set a desired voltage as shown in [Table 1](#) (use a resistor with 1% accuracy).

Refer to the following Quick Setup Guide to configure and power up the board for proper operation. During the power-on process, the expected waveforms are shown in [Figures 2 and 3](#).

Quick Setup Guide

1. Install jumper on J3, shorting EN to VIN.
2. Install jumper on J4, shorting BYP to GND.
3. Connect power supply to J1, with a voltage setting between 1.8V and 5.5V.
4. Connect electronic load to J2.
5. Place scope probes on the V_{OUT} test point and other test points of interest.
6. Turn on the power supply.
7. Monitor the output voltage start-up sequence on the scope. The waveforms will look similar to that shown in [Figures 2 and 3](#).
8. Turn on the electronic load.
9. Measure the output voltage with the voltmeter. The voltage should regulate within datasheet spec limits.

TABLE 1. OUTPUT VOLTAGE PROGRAMMING FOR ISL9120IRA-EVZ

DESIRED OUTPUT VOLTAGE (V)	R ₂ RESISTOR VALUE (k Ω)
2.0	124
2.5	88.7
3.0	68.1
3.3	60.4
3.4	57.6
4.0	46.4
4.5	40.2
5.0	35.7

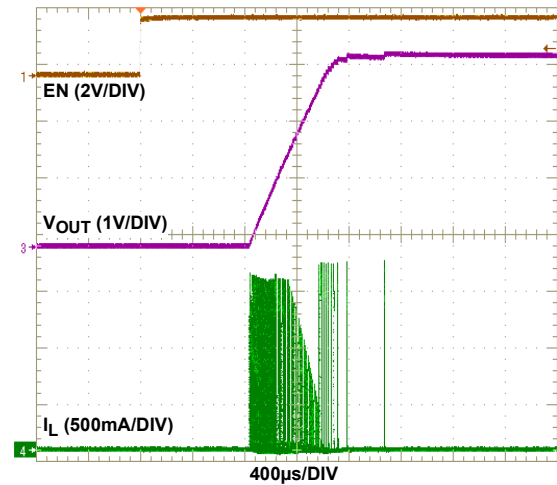

FIGURE 2. SOFT-START ($V_{IN} = 3\text{V}$, $V_{OUT} = 3.3\text{V}$, NO LOAD)

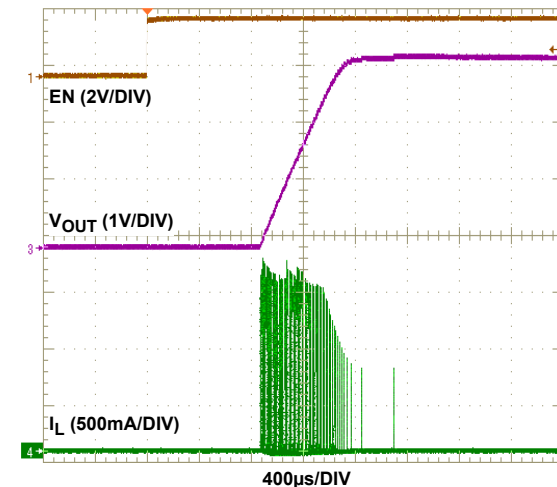

FIGURE 3. SOFT-START ($V_{IN} = 4\text{V}$, $V_{OUT} = 3.3\text{V}$, NO LOAD)

Recommended PCB Layout

Correct PCB layout is critical for proper operation of the ISL9120IR. The input and output capacitors should be positioned as closely to the IC as possible. The ground connections of the input and output capacitors should be kept as short as possible and should be on the component layer to avoid problems that are caused by high switching currents flowing through PCB vias.



FIGURE 4. ISL9120IRA-EVZ EVALUATION BOARD

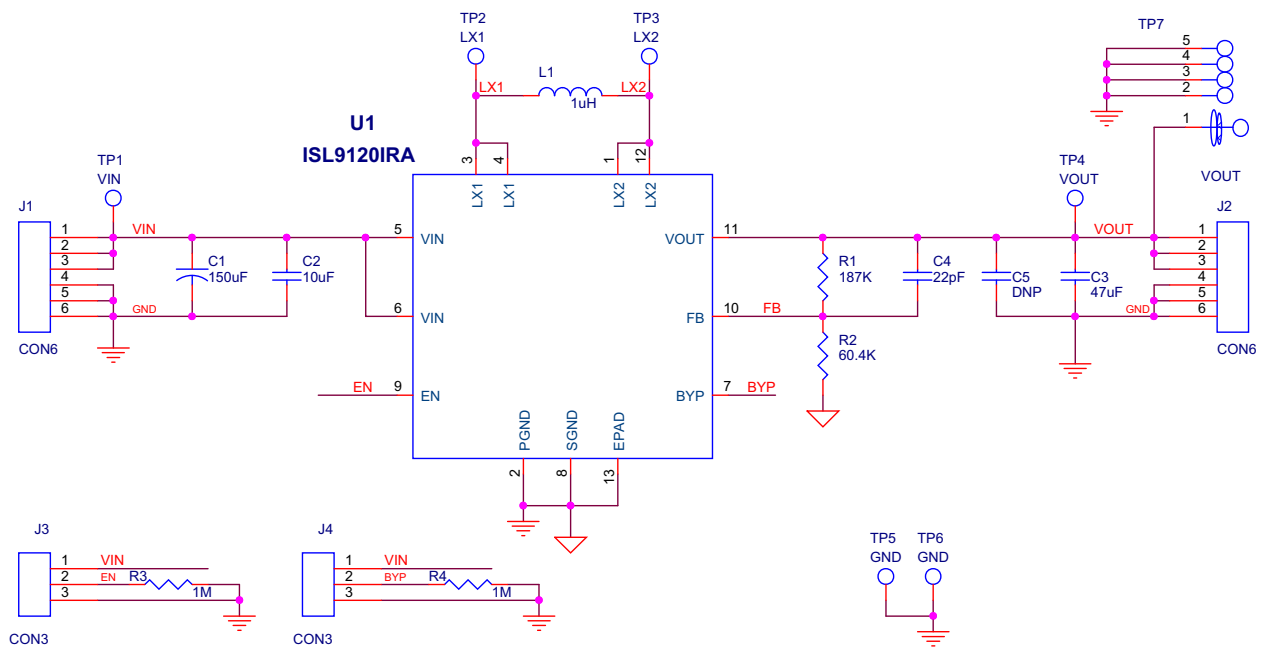

FIGURE 5. ISL9120IRA-EVZ EVALUATION BOARD SCHEMATIC

TABLE 2. ISL9120IRA-EVZ EVALUATION BOARD BILL OF MATERIALS

ITEM#	QTY	REFERENCE DESIGNATOR	PART TYPE	FOOTPRINT	DESCRIPTION	MANUFACTURER
1	1	U1	ISL9120IRA Z	L12.3x3A; TQFN	Intersil ISL9120IR buck-boost regulator with adjustable output voltage	INTERSIL
2	1	L1	1 μ H	0806	Power Inductor Toko DFE201610R series, 2.7A (typical), 80m Ω (typical)	TOKO
3	1	C1	150 μ F	1210	Capacitor, Tantalum	ANY
4	1	C2	10 μ F/16V/X5R	0603	Capacitor, Generic	ANY
5	1	C3	47 μ F/6.3V/X5R	0603	Capacitor, Generic	ANY
6	1	C4	22pF	0402	Capacitor, Generic	ANY
7	1	R1	187k Ω , 1%	0402	Resistor, Generic	ANY
8	1	R2	60.4k Ω , 1%	0402	Resistor, Generic	ANY
9	2	R3, R4	1M Ω , 5%	0603	Resistor, Generic	ANY
10	2	J1, J2	HDR-6	HDR-6	Vert. Pin Header, 6-Pin, 0.1" Spacing, Generic	ANY
11	2	J3, J4	HDR-3	HDR-3	Vert. Pin Header, 3-Pin, 0.1" Spacing, Generic	ANY
12	6	TP1, TP2, TP3, TP4, TP5, TP6	Terminal Pin	0.052" hole	Test Point, Terminal Pin Turret 0.082" [2110-2-00-80-00-00-07-0]	MILL MAX MANUFACTURING CORP.
13	1	TP7	Scope Probe Holder	Scope Probe Holder	Test Point, Scope Probe Holder 131-5031-00	TEKTRONIX



FIGURE 6. ISL9120IRN-EVZ EVALUATION BOARD

ISL9120IRN-EVZ Evaluation Board Schematic

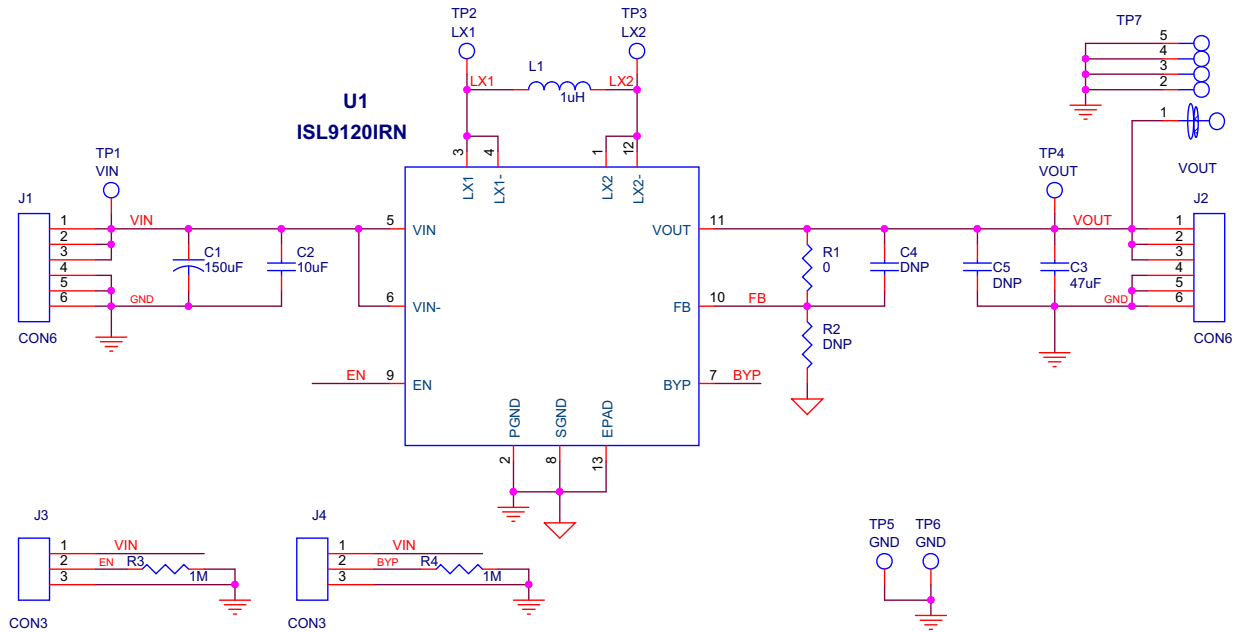

FIGURE 7. ISL9120IRN-EVZ EVALUATION BOARD SCHEMATIC

TABLE 3. ISL9120IRN-EVZ EVALUATION BOARD BILL OF MATERIALS

ITEM#	QTY	REFERENCE DESIGNATOR	PART TYPE	FOOTPRINT	DESCRIPTION	MANUFACTURER
1	1	U1	ISL9120IRNZ	L12.3x3A; TQFN	Intersil ISL9120IR Buck-boost Regulator	INTERSIL
2	1	L1	1µH	0806	Power Inductor Toko DFE201610R series, 2.7A (typical), 80mΩ (typical)	TOKO
3	1	C1	150µF	1210	Capacitor, Tantalum	ANY
4	1	C2	10µF/16V/X5R	0603	Capacitor, Generic	ANY
5	1	C3	47µF/6.3V/X5R	0603	Capacitor, Generic	ANY
6	1	C4	DNP	0402		ANY
7	1	R1	0Ω	0402	Resistor, Generic	ANY
8	1	R2	DNP	0402		ANY
9	2	R3, R4	1MΩ, 5%	0603	Resistor, Generic	ANY
10	2	J1, J2	HDR-6	HDR-6	Vert. Pin Header, 6-Pin, 0.1" Spacing, Generic	ANY
11	2	J3, J4	HDR-3	HDR-3	Vert. Pin Header, 3-Pin, 0.1" Spacing, Generic	ANY
12	6	TP1, TP2, TP3, TP4, TP5, TP6	Terminal Pin	0.052" hole	Test Point, Terminal Pin Turret 0.082" [2110-2-00-80-00-00-07-0]	MILL MAX MANUFACTURING CORP.
13	1	TP7	Scope Probe Holder	Scope Probe Holder	Test Point, Scope Probe Holder 131-5031-00	TEKTRONIX

PCB Layout

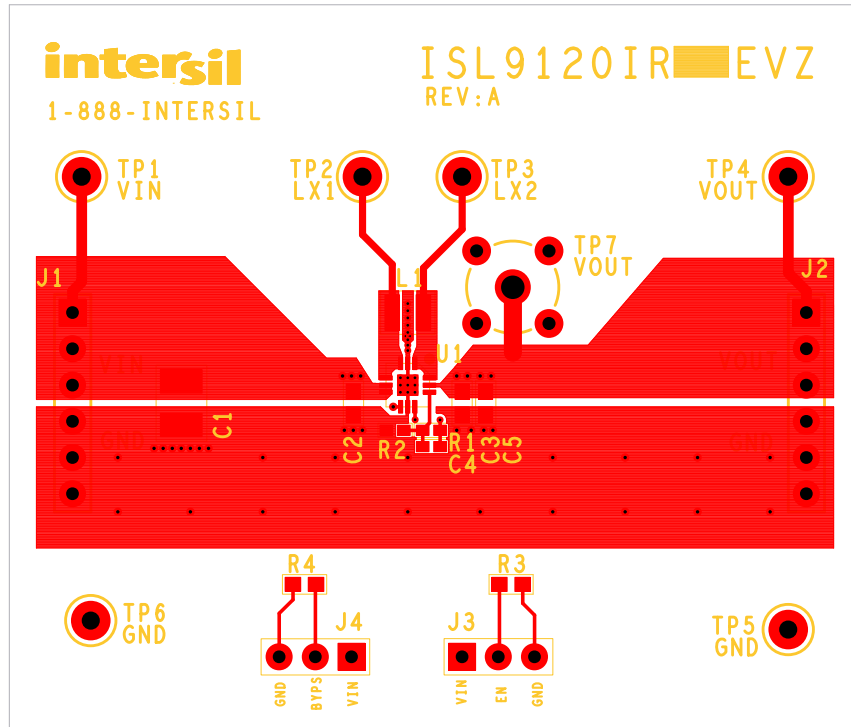

FIGURE 8. TOP LAYER

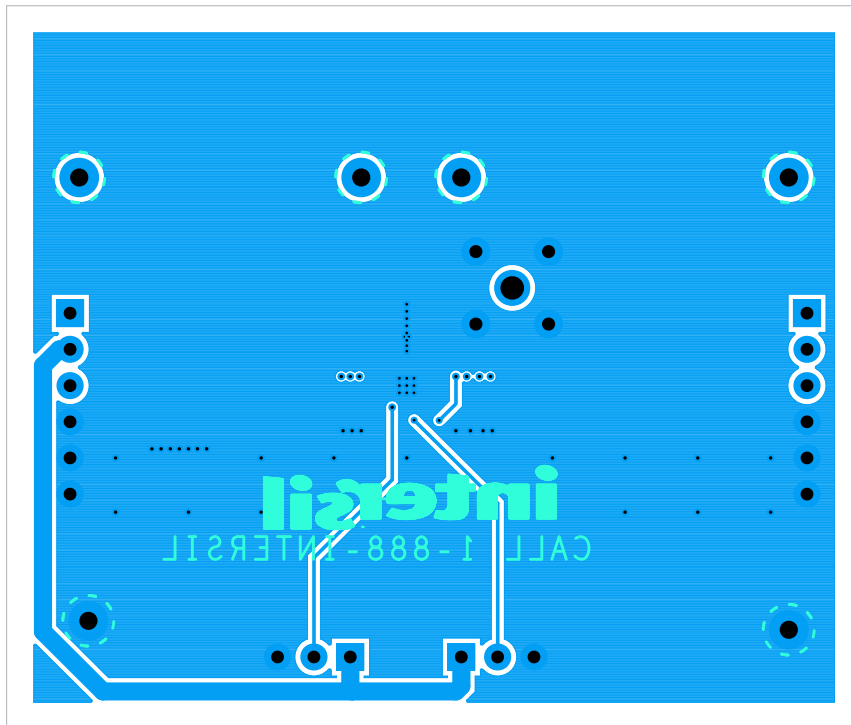

FIGURE 9. BOTTOM LAYER