

ISL9205xEVAL1Z

Evaluation Board Application\Manual

AN1375
Rev 1.00
October 22, 2008

The ISL9205xEVAL1Z is an evaluation tool for the ISL9205 single-cell Li-ion battery charger. The evaluation tool provides a complete evaluation platform addressing all data sheet specifications and functionality. The jumpers on the board facilitate the programming of the charge current and different charging conditions. They can also be used to make other necessary connections, such as current measurement.

The ISL9205 is a fully integrated single-cell Li-ion battery charger that accepts input voltages ranging from up to 6.5V. After being powered up, the ISL9205 is capable of operating at an input voltage as low as 2.5V. The low operating voltage allows the charger to work with a variety of AC adapters.

The ISL9205 offers both a 3 package and pinout option and a total of 5 functional variants. The evaluation board accommodates all of these variants. The board provides the pads for 2 package types: the 16 Ld package and the 10 Ld package. On the 10 Ld package option, there are 2 pin functions for pin 9; temperature function (TEMP) and the remote voltage sensing (VSEN) function. Two 0Ω resistors are used to select these functions. Please refer to the ordering information table to order the evaluation board.

Ordering Information

PART NUMBER	DESCRIPTION
ISL9205EVAL1Z	Evaluation Board for ISL9205
ISL9205AEVAL1Z	Evaluation Board for ISL9205A
ISL9205BEVAL1Z	Evaluation Board for ISL9205B
ISL9205CEVAL1Z	Evaluation Board for ISL9205C
ISL9205DEVAL1Z	Evaluation Board for ISL9205D

Key Features

- A Complete Evaluation Platform for the ISL9205 Charger
- Accommodates All Package Options
- Accepts Input Voltage up to 6.5V
- Flexible Power Connectors each with a Hook and a Solder Pad Providing Variety to Users
- Convenient Jumpers for Programming the Charge Current, Charge Mode and for Current Measurement
- 89mmx65mm Board Size Handy for Evaluation
- Six Thermal Vias in the Thermal Pad Similar To Customers' Thermally Enhanced Environment
- On-Board LEDs for Input $\overline{\text{FAULT}}$ and $\overline{\text{STATUS}}$ State Indication

What is Needed

The following instruments will be needed to perform testing:

- Power supplies:
 - PS1: DC 30V/5A
 - PS2: DC 20V/5A
- DC Electronic load: 20V/5A
- Multimeters
- Function generator
- Oscilloscope
- Cables and wires

Quick Setup Guide (Refer to Figure 1)

DO NOT APPLY POWER UNTIL STEP 8

- Step 1:* Connect a 5V supply PS1 to J1 with the current limit set at 1.2A
- Step 2:* Insert a jumper shunt between pins 2 and 3 of J2, as shown in Figure 1
- Step 3:* Connect a 3.7V supply PS2 to J2 as shown in Figure 1, with the current limit set at 1.2A
- Step 4:* Connect the DC electronic load of 1.2A to J2
- Step 5:* Connect amp-meter I2 as shown in Figure 1
- Step 6:* Insert a thermistor (type 103ET), or a 10k resistor on JP2 to set a valid temperature window
- Step 7:* Switch off all bits of the DIP switch except Bit 9
- Step 8:* Turn on Power Supplies and DC electronic load
- Step 9:* The green LED should be on, indicating normal charging operation
- Step 10:* The current meter I2 in series with PS2 should read about 90mA as the charging current
- Step 11:* Switch on Bit 5 of the DIP switch, the current meter I2 should read about 800mA
- Step 12:* Switch on both Bit 5 and Bit 6; the current meter I2 should read about 1000mA

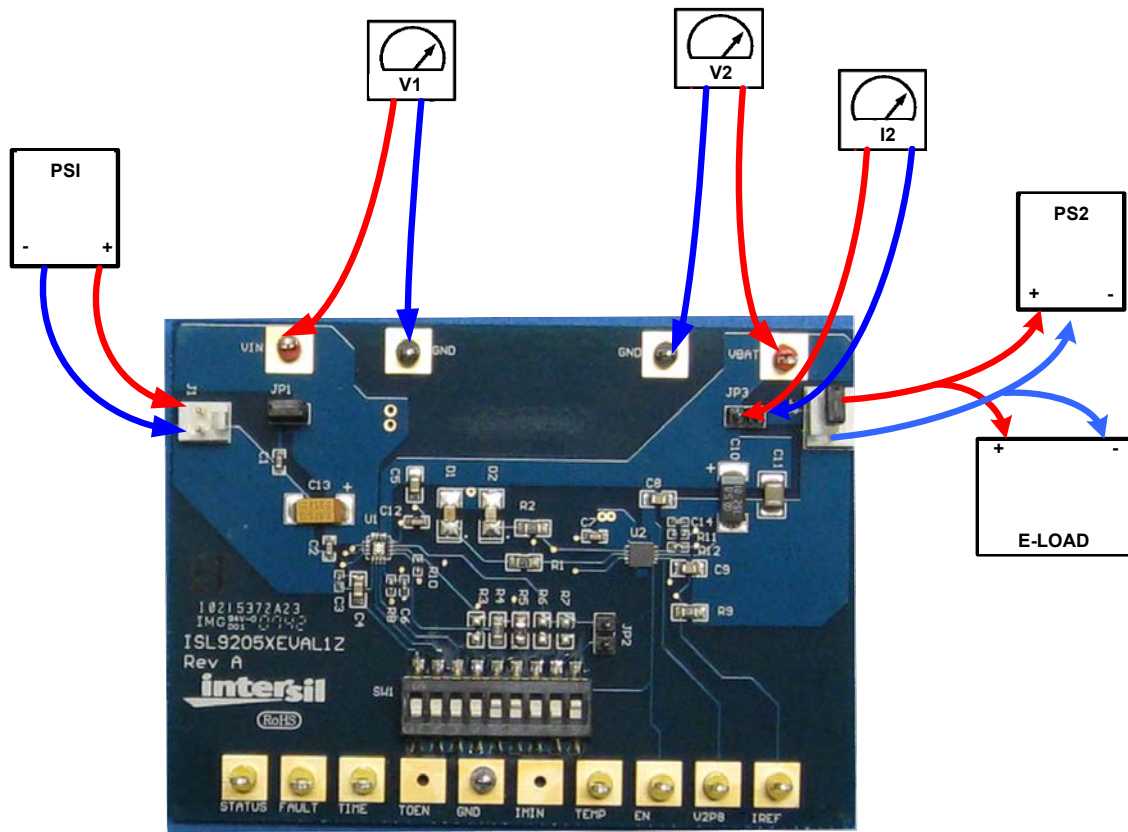

FIGURE 1. CONNECTION OF INSTRUMENTS

Detailed Description

The ISL9205xEVAL1Z is a complete evaluation platform addressing all datasheet specifications and functionality. The jumpers on the board facilitate the necessary connections, such as current measurement.

Jumpers

JP1 - A shunt installed on JP1 connects the input source from connector J1 to the circuit if input current measurement is not needed. The shunt can be replaced by a current meter if input current measurement is needed.

JP2 - Connection for the thermistor. An industrial standard 103ET type of thermistor or similar type that has a room temperature resistance of 10kΩ should be connected to JP2. If temperature measurement is not needed, a regular 10k resistor can be used to set a valid temperature window. Note that leaving JP2 open will cause the charge to shut down.

JP3 - A shunt installed on JP3 connects the VBAT pin to the output connector J2 if output current measurement is not needed. The shunt can be replaced by a current meter if output current measurement is needed.

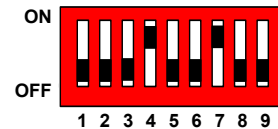

FIGURE 2. DIP SWITCH BIT DESCRIPTION

DIP Switch Settings

A 9-bit DIP switch is provided to set up current reference, end-of-charge (EOC) current, and so on. The functionality of the bits are described in Table 1.

TABLE 1. JUMPER SETTINGS

JUMPER	FUNCTION
JP1	Connect the input power at J1 to VIN pin
JP2	For thermistor connection
JP3	Connects VBAT to connector J2

TABLE 2. DIP SWITCH SETTINGS

BIT	DESCRIPTION	ON	OFF	REMARK
1	Time-out period setting	5.8 hours	3.5 hours	
2	Time-out enable	Disabled	Enabled	Not connected
3	Charger enable	Charger disabled	Charger enabled	
4	IMIN setting	IMIN = 80mA	I _{MIN} = 10mA	
5	IREF setting 1	ICH = 800mA	I _{BAT} = 90mA	BIT6 = OFF
6	IREF setting 2	ICH = 1A	I _{BAT} = 800mA	BIT5 = ON
7	TEMP normal	Normal		All off simulates battery removal
8	TEMP high	Too hot		
9	TEMP low	Too cold		

Board Layout Information

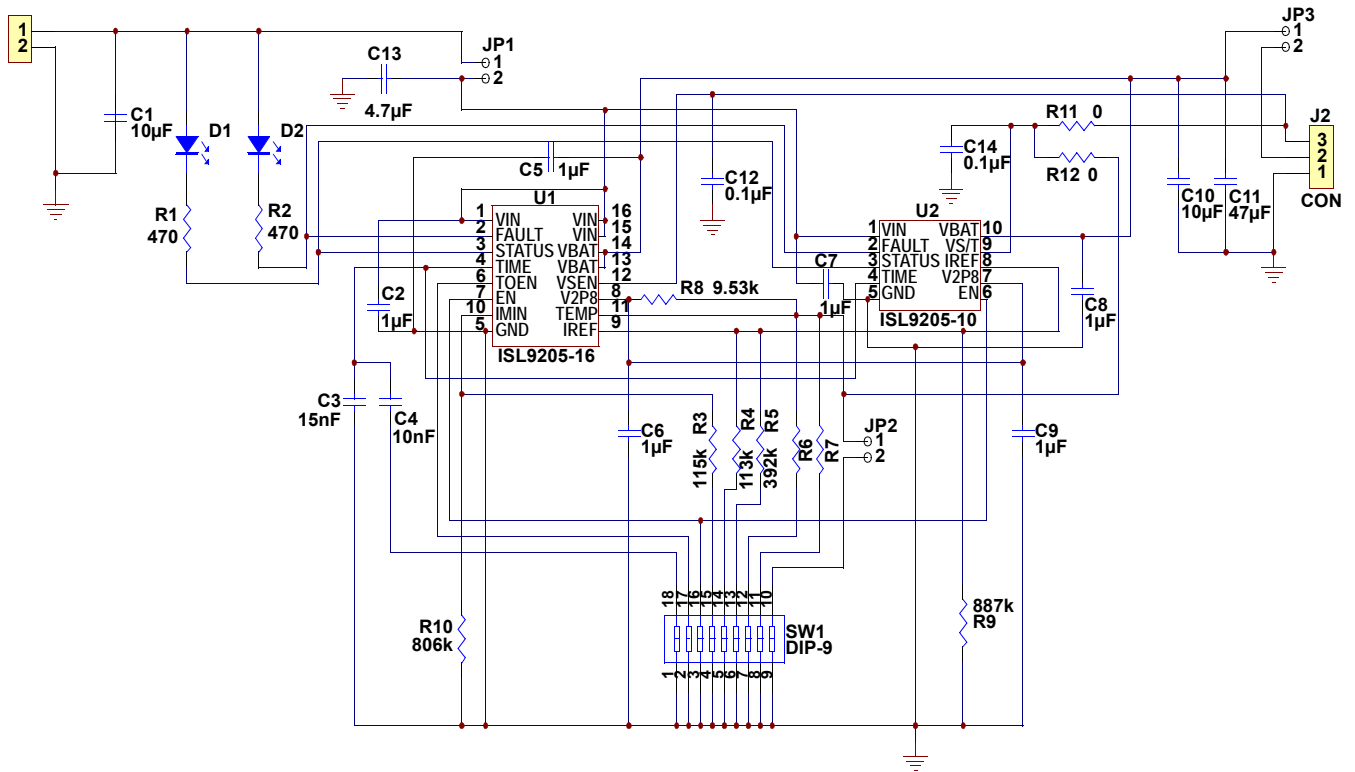

FIGURE 3. SCHEMATIC OF PCB BOARD

PCB Layout

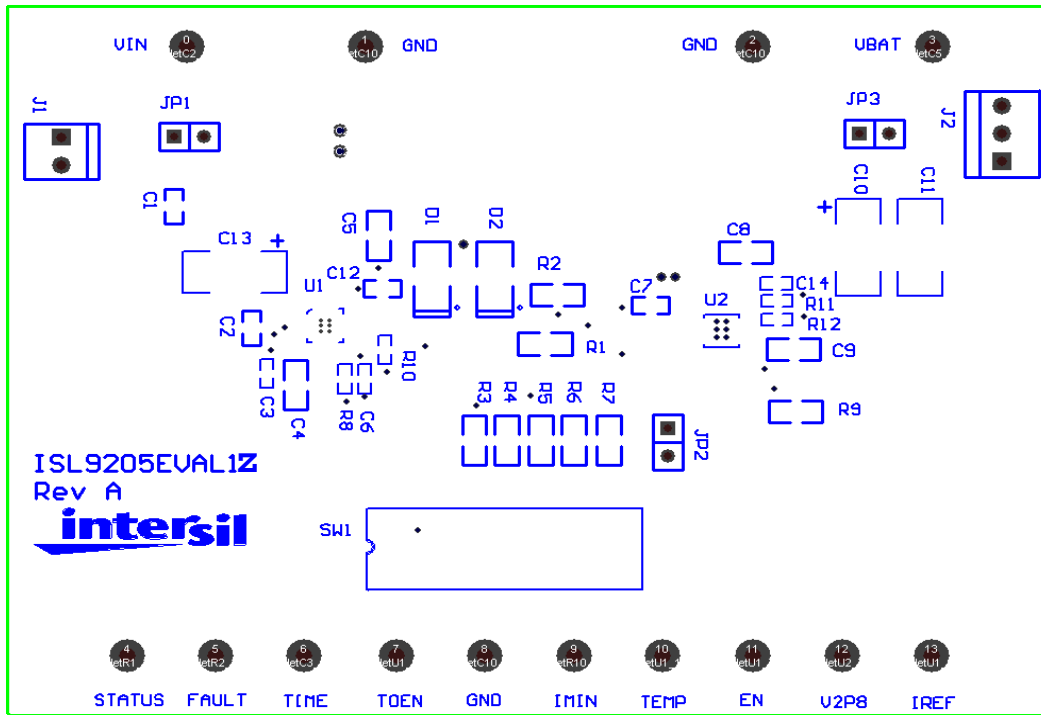

FIGURE 4. SILK LAYER

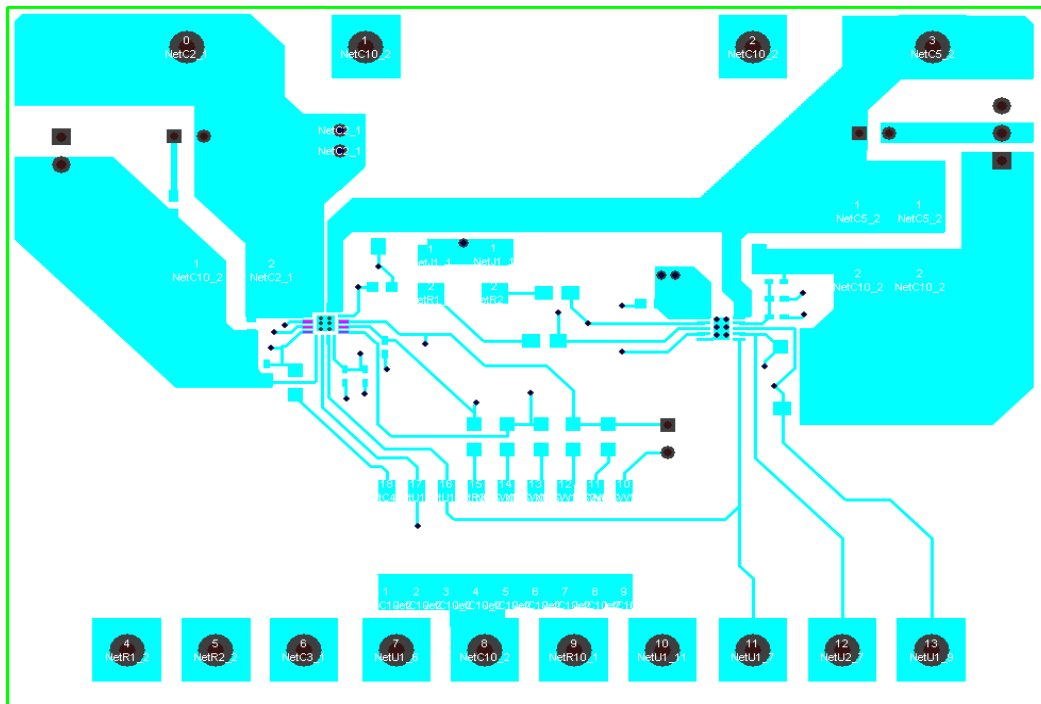

FIGURE 5. TOP LAYER

PCB Layout (Continued)

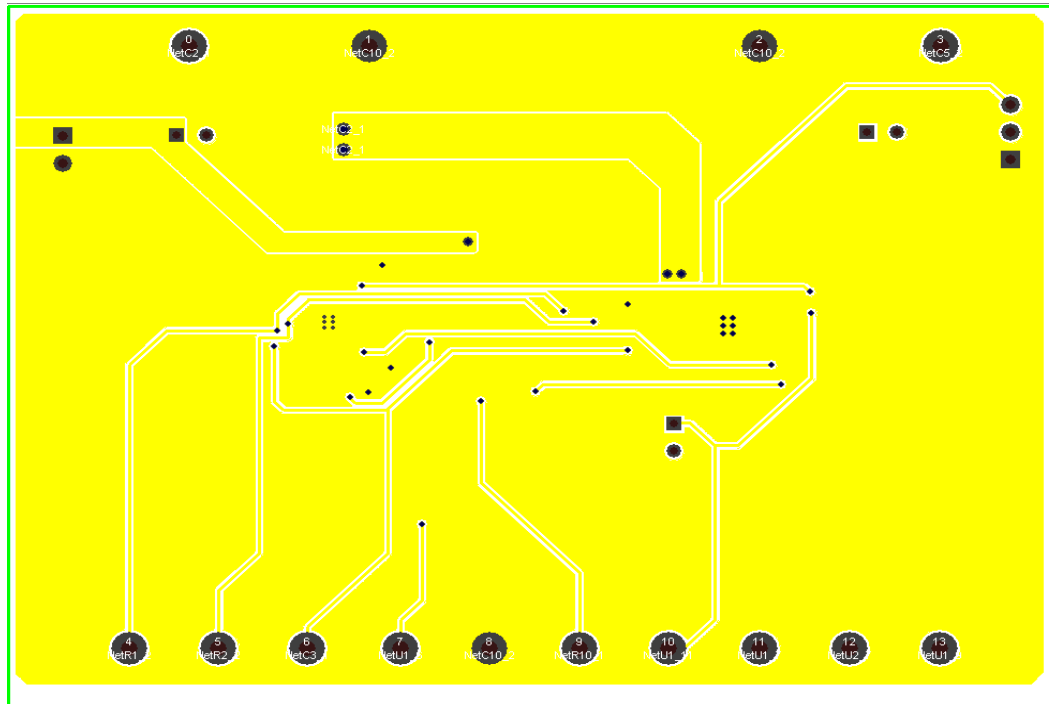

FIGURE 6. BOTTOM LAYER

ISL9205EVAL1Z Bill of Materials

ITEM	QTY	REFERENCE	PART DESCRIPTION	PCB FOOTPRINT	PART NUMBER	VENDOR
1	1	U1	ISL9205 Charger IC	3x3 QFN 16L	ISL9205	Intersil
2	2	R1, R2	470Ω, 5%, 1/8W, Chip	0805	ERJ-6GEYJ471V	Panasonic
3	1	R3	115k, 1%, 1/16W, Chip	0402	ERJ-2RKF1153X	Panasonic
4	1	R4	113k, 1%, 1/8W, Chip	0805	ERJ-6ENF1133V	Panasonic
5	1	R5	392k, 1%, 1/8W, Chip	0805	ERJ-6ENF3923V	Panasonic
6	1	R9	887k, 1%, 1/8W, Chip	0805	ERJ-6ENF8873V	Panasonic
7	1	R10	806k, 1%, 1/16W	0402	ERJ-2RKF8063X	Panasonic
8	1	R8	9.53k, 1%, 1/16W, Chip	0402	ERJ-2RKF9531X	Panasonic
9	2	R6, R7 (do not populate)				
10	2	R11, R12 (do not populate)	0Ω, 5%, 1/16W	0402	9C04021A0R00JLHF3	YAGEO
11	1	C13	4.7μF, 35V, Tantalum		ECS-T1VC475R	Panasonic
12	2	C1, C12	0.1μF, 50V, X7R Ceramic	0603	C1608X7R1H104K	TDK
13	2	C6, C14	0.1μF, 10V, X5R Ceramic	0402	C1005X5R1A104K	TDK
14	2	C2, C7	1.0μF, 6.3V, X5R Ceramic	0603	ECJ-1VB0J105K	Panasonic
15	1	C3	15nF, 16V, X7R Ceramic	0402	ECJ-0EB1C153K	Panasonic
16	1	C4	10nF, 50V, X7R Ceramic	0805	ECJ-2VB1H103K	Panasonic
17	2	C5, C8	1μF, 25V, X5R Ceramic	0805	ECJ-2FB1E105K	Panasonic
18	1	C9	1μF, 25V, X5R Ceramic	0805	ECJ-2FB1E105K	Panasonic
19	3	C11	47μF, 6.3V, X5R, Ceramic	1210	ECJ-4YB0J476M	Panasonic
20	1	C10	10μF, 25V, Tantalum		ECS-T1EC106R	Panasonic
21	1	J1	2.54mm Center Header, 2ckt		22-11-2022	Molex
22	1	SW1	DIP Switch, 9 POS, SMT	DIP18	SDA09H0SKD	ITT/C&K
23	1	J2	2.54mm Center Header, 3ckt		22-11-2032	Molex
24	2	VIN, VBAT	Test point, Red		5010	Keystone
25	9	FAULT, STATUS, TIME, IREF, IMIN, TOEN, EN, V2P8, TEMP	Test point, Yellow		5014	Keystone
26	3	GND1, GND2, GND3	Test point, Black		5011	Keystone
27	3	JP1, JP2, JP3	2.54mm header, 2ckt		22-28-4020	Molex
28	1	D1	Green LED	0805	SML-LXT0805GW-TR	Lumex
29	1	D2	Red LED	0805	SML-LXT0805IW-TR	Lumex

ISL9205DEVAL1Z Bill of Materials

ITEM	QTY	REFERENCE	PART DESCRIPTION	PCB FOOTPRINT	PART NUMBER	VENDOR
1	1	U1	ISL9205D Charger IC	3x3 DFN 10L	ISL9205D	Intersil
2	2	R1, R2	470Ω, 5%, 1/8W, Chip	0805	ERJ-6GEYJ471V	Panasonic
3	1	R4	113k, 1%, 1/8W, Chip	0805	ERJ-6ENF1133V	Panasonic
4	1	R5	392k, 1%, 1/8W, Chip	0805	ERJ-6ENF3923V	Panasonic
5	1	R9	887k, 1%, 1/8W, Chip	0805	ERJ-6ENF8873V	Panasonic
6	1	R8	9.53k, 1%, 1/16W, Chip	0402	ERJ-2RKF9531X	Panasonic
7	2	R6, R7 (do not populate)				
8	1	R11 (do not populate)				
9	1	R12	0Ω, 5%, 1/16W	0402	9C04021A0R00JLHF3	YAGEO
10	1	C13	4.7μF, 35V, Tantalum		ECS-T1VC475R	Panasonic
11	2	C1, C12	0.1μF, 50V, X7R Ceramic	0603	C1608X7R1H104K	TDK
12	2	C6, C14	0.1μF, 10V, X5R Ceramic	0402	C1005X5R1A104K	TDK
13	2	C2, C7	1.0μF, 6.3V, X5R Ceramic	0603	ECJ-1VB0J105K	Panasonic
14	1	C3	15nF, 16V, X7R Ceramic	0402	ECJ-0EB1C153K	Panasonic
15	1	C4	10nF, 50V, X7R Ceramic	0805	ECJ-2VB1H103K	Panasonic
16	2	C5, C8	1μF, 25V, X5R Ceramic	0805	ECJ-2FB1E105K	Panasonic
17	1	C9	1μF, 25V, X5R Ceramic	0805	ECJ-2FB1E105K	Panasonic
18	3	C11	47μF, 6.3V, X5R, Ceramic	1210	ECJ-4YB0J476M	Panasonic
19	1	C10	10μF, 25V, Tantalum		ECS-T1EC106R	Panasonic
20	1	J1	2.54mm Center Header, 2ckt		22-11-2022	Molex
21	1	SW1	DIP Switch, 9 POS, SMT	DIP18	SDA09H0SKD	ITT/C&K
22	1	J2	2.54mm Center Header, 3ckt		22-11-2032	Molex
23	2	VIN, VBAT	Test point, Red		5010	Keystone
24	7	FAULT, STATUS, TIME, IREF, EN, V2P8, TEMP	Test point, Yellow		5014	Keystone
25	3	GND1, GND2, GND3	Test point, Black		5011	Keystone
26	3	JP1, JP2, JP3	2.54mm header, 2ckt		22-28-4020	Molex
27	1	D1	Green LED	0805	SML-LXT0805GW-TR	Lumex
28	1	D2	Red LED	0805	SML-LXT0805IW-TR	Lumex

ISL9205AEVAL1Z, ISL9205BEVAL1Z, ISL9205CEVAL1Z Bill of Materials

ITEM	QTY	REFERENCE	PART DESCRIPTION	PCB FOOTPRINT	PART NUMBER	VENDOR
1	1	U1	ISL9205A, ISL9205B, ISL9205C Charger IC	3x3 DFN 10L	ISL9205A/B/C	Intersil
2	2	R1, R2	470Ω, 5%, 1/8W, Chip	0805	ERJ-6GEYJ471V	Panasonic
3	1	R4	113k, 1%, 1/8W, Chip	0805	ERJ-6ENF1133V	Panasonic
4	1	R5	392k, 1%, 1/8W, Chip	0805	ERJ-6ENF3923V	Panasonic
5	1	R9	887k, 1%, 1/8W, Chip	0805	ERJ-6ENF8873V	Panasonic
6	1	R8	9.53k, 1%, 1/16W, Chip	0402	ERJ-2RKF9531X	Panasonic
7	2	R6, R7 (do not populate)				
8	1	R11	0Ω, 5%, 1/16W	0402	9C04021A0R00JLHF3	YAGEO
9	1	R12 (do not populate)				
10	1	C13	4.7μF, 35V, Tantalum		ECS-T1VC475R	Panasonic
11	2	C1, C12	0.1μF, 50V, X7R Ceramic	0603	C1608X7R1H104K	TDK
12	2	C6, C14	0.1μF, 10V, X5R Ceramic	0402	C1005X5R1A104K	TDK
13	2	C2, C7	1.0μF, 6.3V, X5R Ceramic	0603	ECJ-1VB0J105K	Panasonic
14	1	C3	15nF, 16V, X7R Ceramic	0402	ECJ-0EB1C153K	Panasonic
15	1	C4	10nF, 50V, X7R Ceramic	0805	ECJ-2VB1H103K	Panasonic
16	2	C5, C8	1μF, 25V, X5R Ceramic	0805	ECJ-2FB1E105K	Panasonic
17	1	C9	1μF, 25V, X5R Ceramic	0805	ECJ-2FB1E105K	Panasonic
18	3	C11	47μF, 6.3V, X5R, Ceramic	1210	ECJ-4YB0J476M	Panasonic
19	1	C10	10μF, 25V, Tantalum		ECS-T1EC106R	Panasonic
20	1	J1	2.54mm Center Header, 2ckt		22-11-2022	Molex
21	1	SW1	DIP Switch, 9 POS, SMT	DIP18	SDA09H0SKD	ITT/C&K
22	1	J2	2.54mm Center Header, 3ckt		22-11-2032	Molex
23	2	VIN, VBAT	Test point, Red		5010	Keystone
24	7	FAULT, STATUS, TIME, IREF, EN, V2P8, TEMP	Test point, Yellow		5014	Keystone
25	3	GND1, GND2, GND3	Test point, Black		5011	Keystone
26	3	JP1, JP2, JP3	2.54mm header, 2ckt		22-28-4020	Molex
27	1	D1	Green LED	0805	SML-LXT0805GW-TR	Lumex
28	1	D2	Red LED	0805	SML-LXT0805IW-TR	Lumex