

## ISL9214AEVAL1Z

Evaluation Board Application Manual

AN1260  
Rev 1.00  
Jan 26, 2010

### Description

The ISL9214AEVAL1Z is an evaluation tool for the ISL9214A single-cell Li-ion battery charger. The evaluation tool provides a complete evaluation platform addressing all data sheet specifications and functionality. The jumpers on the board facilitate the programming of the charge current and the different charging conditions and can be used to make other necessary connections, such as current measurement.

The ISL9214A is a dual input, fully integrated single-cell Li-ion battery charger. The ISL9214A charger accepts two input sources: one from a USB port and the other from a desktop cradle. Both inputs accept input voltages ranging from 4.5V up to 28V. Due to the high voltage capability, the components associated with the cradle input circuit on the evaluation board are good for a 28V supply.

The components assembled in the center square constitute a complete charger, indicating the space saving advantage of the typical ISL9214A installation in space-limited applications.

### Ordering Information

PART #	DESCRIPTION
ISL9214AEVAL1Z	Evaluation Board for ISL9214A

### Pin Configuration

ISL9214A  
10 LD DFN  
TOP VIEW

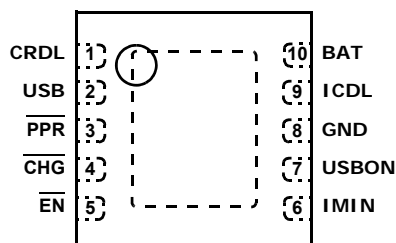

### Features

- A Complete Evaluation Platform for the ISL9214A Charger
- The Center Square Suggesting the Space Saving Advantage of the Typical Components Assembly
- Both Inputs Accept Voltage up to 28V
- Flexible Power Connectors Each with a Hook and a Solder Pad Providing Variety to Users
- USB Port On Board Accepts Power Directly From USB Cable
- Convenient Jumpers for Programming the Charge Current, Charge Mode and for Current Measurement
- 3.5x2.5 Square Inches Board Size Handy for Evaluation
- Thermal Vias in the Thermal Pad Similar To Customers' Thermally Enhanced Environment
- On-Board LEDs for Input  $\overline{\text{PPR}}$  and  $\overline{\text{CHG}}$  State Indication
- Pb-Free (RoHS Compliant)

### What is Needed

The following instruments will be needed to perform testing:

- Power supplies:
  - 1) PS1: DC 30V/2A
  - 2) PS2: DC 10V/2A
  - 3) PS3: DC 10V/2A
- DC Electronic load: 20V/2A
- Multimeters
- Function generator
- Oscilloscope
- Cables and wires

## Quick Setup Guide (Refer to Figure 1)

### DO NOT APPLY POWER UNTIL STEP 6

#### For Cradle Input:

- Step 1: Connect a 5V supply PS1 to CRDL input (J1, upper +) with the current limit set at 1.3A
- Step 2: Connect a 3.7V supply PS3 to BAT output (J3, upper +) with the current limit set at 1.3A
- Step 3: Connect a current meter to JP6, as shown in Figure 1
- Step 4: Connect the DC electronic load of 1.2A to BAT (J3, upper +)
- Step 5: Insert a jumper shunt on JP1, all other jumper shunts are not installed
- Step 6: Turn on Power Supplies and DC electronic load, adjust the power supply PS3 such that the voltmeter V2 reads 3.7V
- Step 7: Both the red and the green LEDs should be on, indicating power on and charging condition
- Step 8: The current meter I2 should read about 0.28A as the charging current
- Step 9: Insert a jumper shunt on JP7 and the current meter I2 should read about 0.575A charging current
- Step 10: Insert a jumper shunt on both JP7 and JP8, the current meter I2 should read about 1.04A charging current
- Step 11: Reduce the voltage at PS3 to 2.0V for trickle charge currents. Repeat Steps 8, 9 and 10. The current reading should be 52mA, 103mA and 187mA for steps 8, 9 and 10, respectively
- Step 12: Slowly reduce the DC electronic load current until the green LED turns off. The current meter I2 should read about 47mA EOC current
- Step 13: Insert a jumper shunt on JP5 and repeat Step 12, the current meter I2 should read 93mA EOC current

#### For USB Input:

- Step 1: Connect a 5V supply PS2 to USB with the current limit set at 0.7A
- Step 2: Connect a 3.7V supply PS3 to BAT (J3 upper +) with the current limit set at 0.7A
- Step 3: Connect the DC electronic load of 0.6A to BAT (upper +)
- Step 4: Connect a current meter to JP6 as shown in Figure 1
- Step 5: Install a jumper shunt on JP2 and a jumper shunt on JP4 to the USBON position, all other jumpers shunts are not installed
- Step 6: Turn on Power Supplies and DC electronic load, adjust the power supply PS3 such that the voltmeter V2 reads 3.7V
- Step 7: Both the red and the green LEDs should be on, indicating power on and charging condition
- Step 8: The current meter I2 should read about 0.38A charging current
- Step 9: Reduce the voltage at PS3 to 2.0V for trickle charge current. Repeat Step 8. The reading should be around 80mA
- Step 10: Slowly reduce the electronic load current until the green LED turns off, the current meter I2 should read about 55mA EOC current
- Step 11: Insert a jumper shunt on JP5 and repeat Step 10. The current meter I2 should read 75mA EOC current

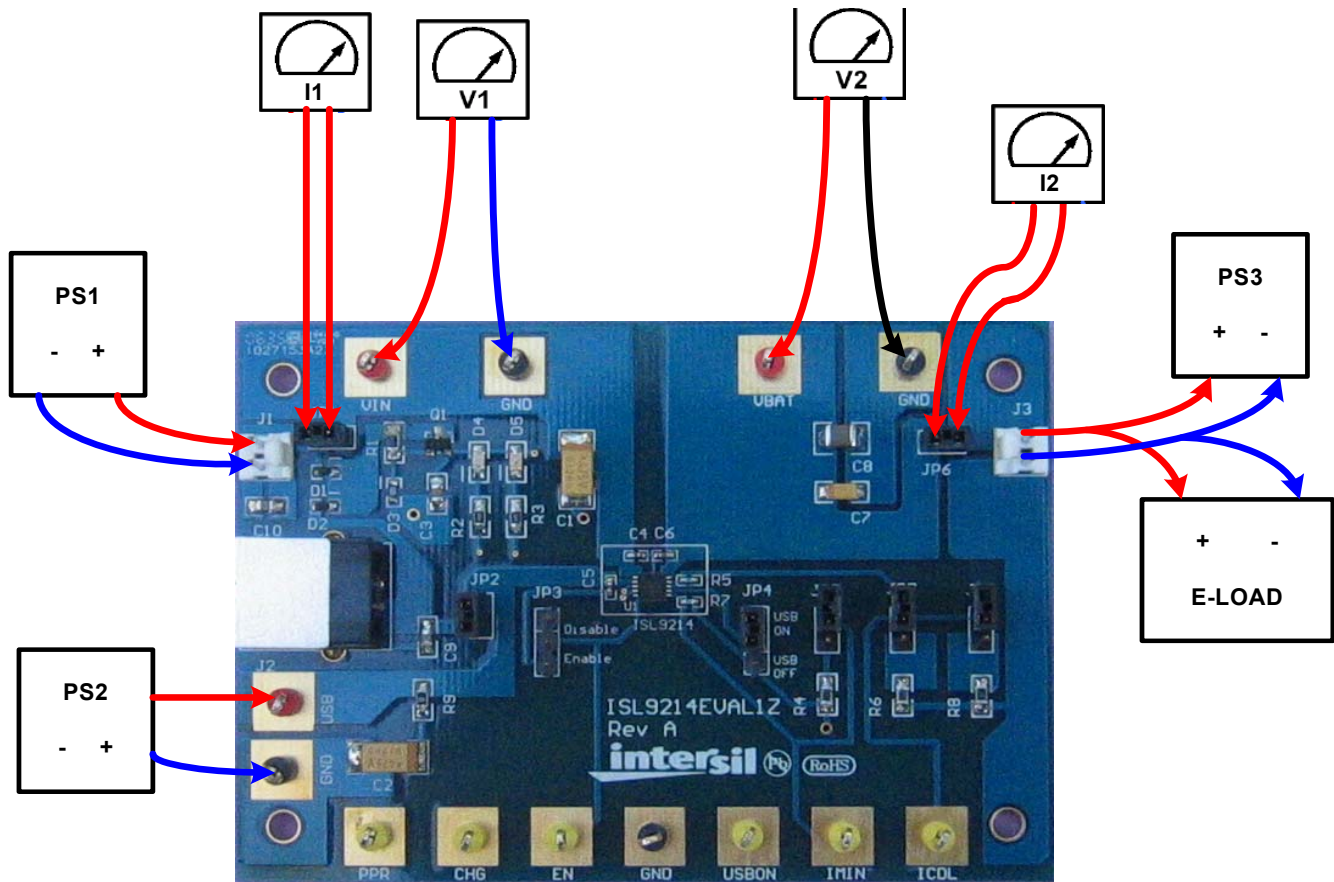

FIGURE 1. CONNECTION OF INSTRUMENTS

## Description of Jumper Settings

**JP1** - A shunt installed on JP1 connects the input source from connector J1 to the circuit if input current measurement is not needed. The shunt can be replaced by a current meter if input current measurement is needed, as shown in Figure 1.

**JP2** - A shunt installed on JP2 connects the input source from the USB port connector to the USB pin if a USB port is used for the evaluation.

**JP3** - Connects the  $\overline{EN}$  pin to a pull-up voltage or GND. The pull-up voltage is regulated 3.3V from the input source (either Cradle or USB). If there is no shunt installed on JP3, the  $\overline{EN}$  pin is internally pulled down to logic LOW, which enables the charger. If a shunt is installed across the two jumper pins labeled as "Enable", the  $\overline{EN}$  pin is driven to logic LOW, the charger is enabled, same as floating. If the shunt is installed across the two jumper pins labeled as "Disable", the  $\overline{EN}$  pin is driven to logic HIGH, which disables the charger.

**JP4** - ON/OFF control for USB input. Install a jumper shunt on USB OFF position to turn off the USB charge but has no impact on the cradle input charge.

**JP5** - Parallels an additional 11.8k resistor to the IMIN pin (total  $R_{IMIN} = 5.9k$ ), such that the End-of-Charge

Current will be increased to 93mA ( $R_{IMIN}$  is 11.8k and the EOC current is 46.5mA without the shunt).

**JP6** - A shunt installed on JP6 connects the BAT pin to the output connector J3 if output current measurement is not needed. The shunt can be replaced by a current meter if output current measurement is needed as shown in Figure 1.

**JP7** - Parallels an additional 23.7k resistor to the ICDL pin (total  $R_{ICDL} = 11.85k$ ), such that the cradle charge current will be increased to 0.575A ( $R_{IREF}$  is 23.7k and the charge current is 0.28A if the shunts on both JP7 and JP8 are removed).

**JP8** - Parallels an additional 14.7k resistor to the ICDL pin (when JP7 is installed, total  $R_{ICDL} = 6.56k$ ), such that the cradle charge current will be increased to 1.04A.

TABLE 1. JUMPER SETTING SUMMARY

JUMPER	POSITION	FUNCTION
JP1	Shunt installed	Connects input source at J1 to CRDL pin
JP2	Shunt installed	Connects input source from USB port connector to USB pin
JP3	Shunt on Disable	Charger disabled
	Shunt on Enable	Charger enabled
	Shunt not installed	Charger enabled
JP4	Shunt on USB OFF	Turns off USB charge
	Shunt on USB ON	Turns on USB charge
	Shunt not installed	Turns off USB charge
JP5	Shunt installed	Sets CRDL and USB EOC current to 93mA
JP6	Shunt installed	Connects BAT to J3
JP7	Shunt installed	Sets CRDL charging current to 0.575A, if shunt on JP7 is not installed
JP8	Shunt installed	Sets CRDL charging current to 1.04A, if shunt on JP7 is also installed

### Board Design

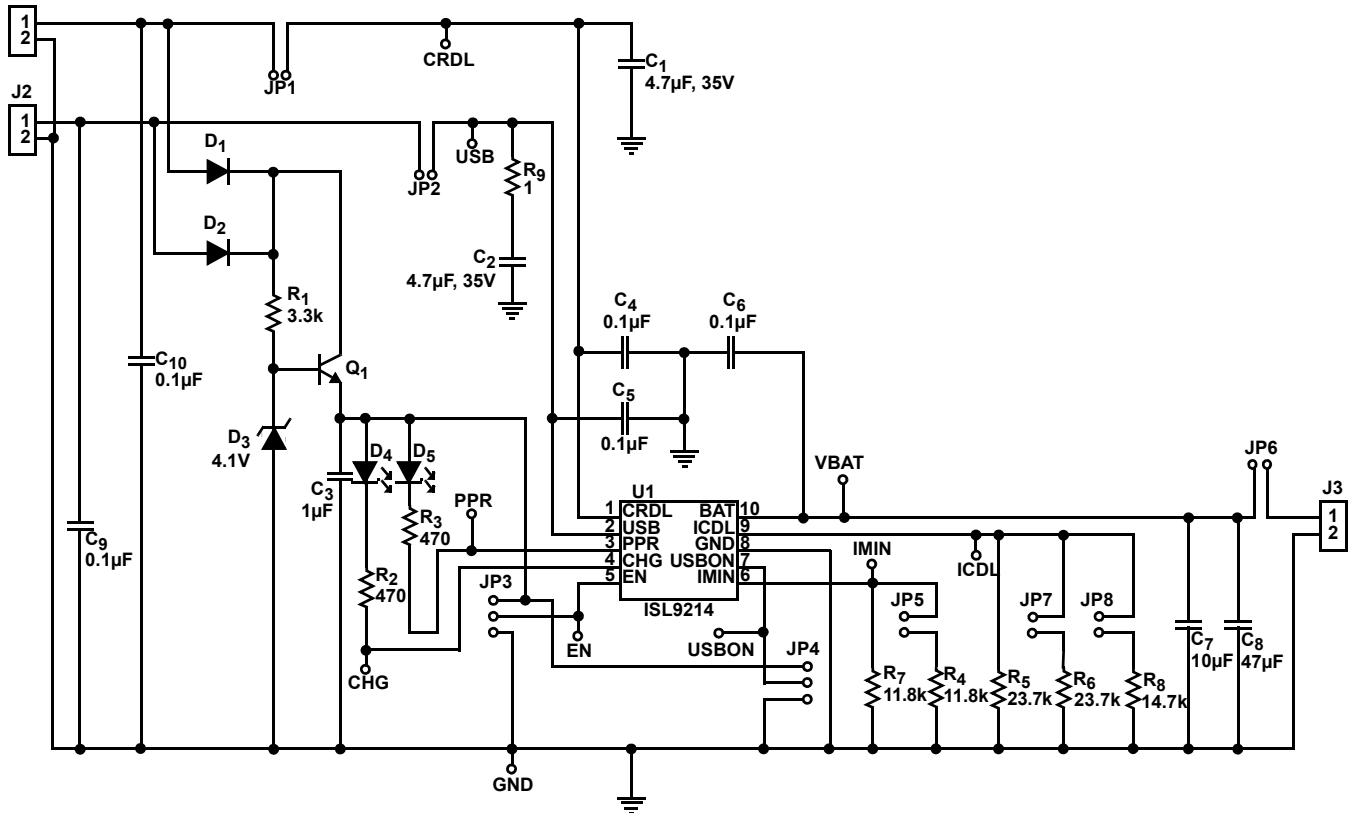

FIGURE 2. SCHEMATIC

## ISL9214AEVAL1Z Bill of Materials

ITEM	QTY	REFERENCE	PART DESCRIPTION	PCB FOOTPRINT	PART NUMBER	VENDOR
1	1	U1	ISL9214A Charger	3x3 DFN	ISL9214A	Intersil
2	1	R1	3.3k, 5%, SMD Resistor	0805	ERJ-6GEYJ332V	Panasonic
3	2	R2, R3	470Ω, 5%, SMD Resistor	0805	ERJ-6GEYJ471V	Panasonic
4	1	R4	11.8k, 1%, SMD Resistor	0805	ERJ-6ENF1182V	Panasonic
5	1	R7	11.8k, 1%, SMD Resistor	0402	ERJ-2RKF1182X	Panasonic
6	1	R5	23.7k, 1%, SMD Resistor	0402	ERJ-2RKF2372X	Panasonic
7	1	R6	23.7k, 1%, SMD Resistor	8085	ERJ-6ENF2372V	Panasonic
8	1	R8	14.7k, 1%, SMD Resistor	0805	ERJ-6ENF1472V	Panasonic
9	1	R9	0Ω 5%, SMD Resistor	0805	9C08052A0R00JLHFT	Yageo
10	2	C1, C2	4.7μF, 35V, Tantalum	0805	ECS-T1VC475R	Panasonic
11	2	C9, C10	0.1μF, 50V, X7R Ceramic	0805	C2012X7R1H104K	TDK
12	1	C7	10μF, 6.3V Tantalum	1206	ECS-T0JY106R	Panasonic
13	1	C8	47μF, 6.3V, X5R Ceramic	1210	ECJ-4YB0J476M	Panasonic
14	1	C3	1μF, 25V, X5R Ceramic	0805	ECJ-2FB1E105K	Panasonic
15	3	C4, C5, C6	0.01μF, 50V, X7R Ceramic	0402	C0402C103K5RACTU	Kemet
16	2	J1, J3	2.54mm Center Header, 2 CKT		22-11-2022	Molex
17	3	CRDL, USB, VBAT	Test point, Red		5010	Keystone
18	6	PPR, CHG, EN, IMIN, USBON	Test point, Yellow		5014	Keystone
		ICDL				
19	3	GND1, GND2, GND3	Test point, Black		5011	Keystone
20	6	JP1, JP2, JP5, JP6, JP7, JP8	2.54mm header, 2 CKT		22-28-4020	Molex
21	2	JP3, JP4	2.54mm header, 3 CKT		22-28-4030	Molex
22	1	D4	Green LED	0805	SML-LXT0805GW-TR	Lumex
23	1	D5	Red LED	0805	SML-LXT0805IW-TR	Lumex
24	2	D1, D2	Switching Diode 100V, 250mA	SOD-523	CMOD4448	Central Diodes
25	1	D3	Zener diode 4.3V, 200mW	SOD-323	MMSZ5229BS	Diodes
26	1	Q1	60V, 1A, NPN Transistor	SOT-23	FMMT491TA	Zetex
27	1	J2	Type B, Female USB	Type B	787780-1	Amp/Tyco
28	4		Pumpon, 0.44x0.2, black		SJ-5303	3M/ESM

# PCB Layout

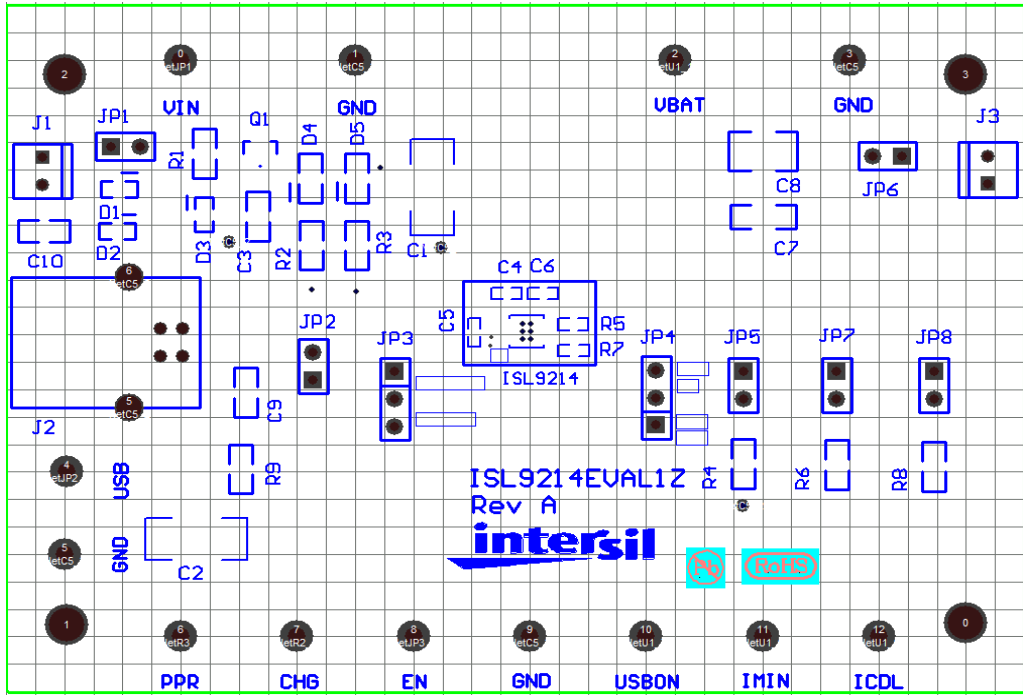

FIGURE 3. SILK LAYER

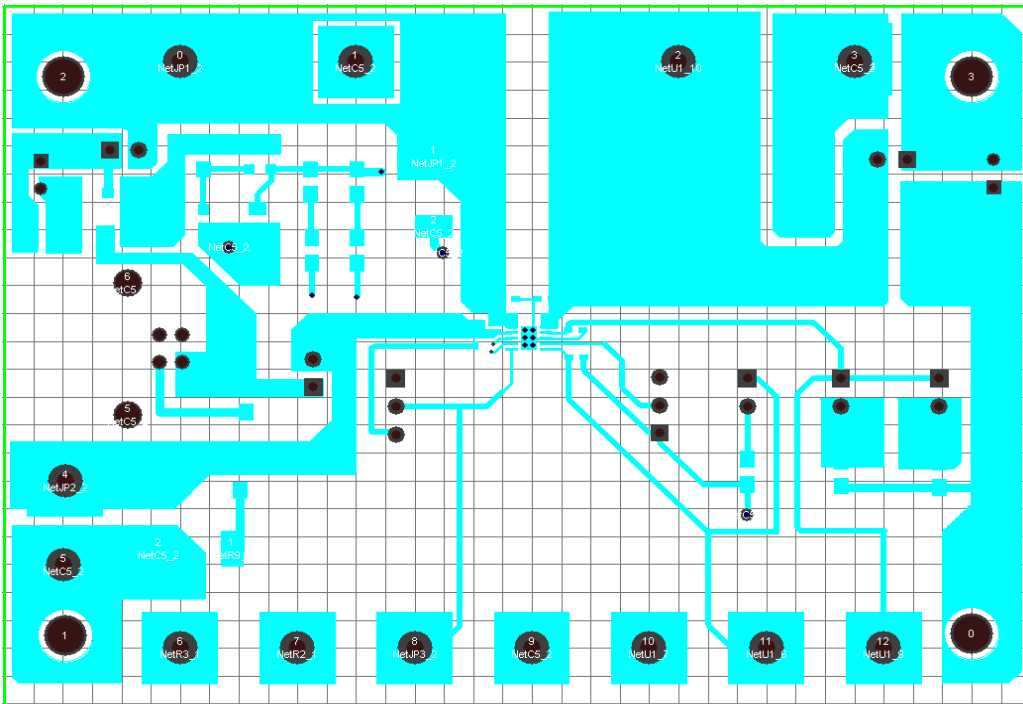

FIGURE 4. TOP LAYER

# PCB Layout (Continued)

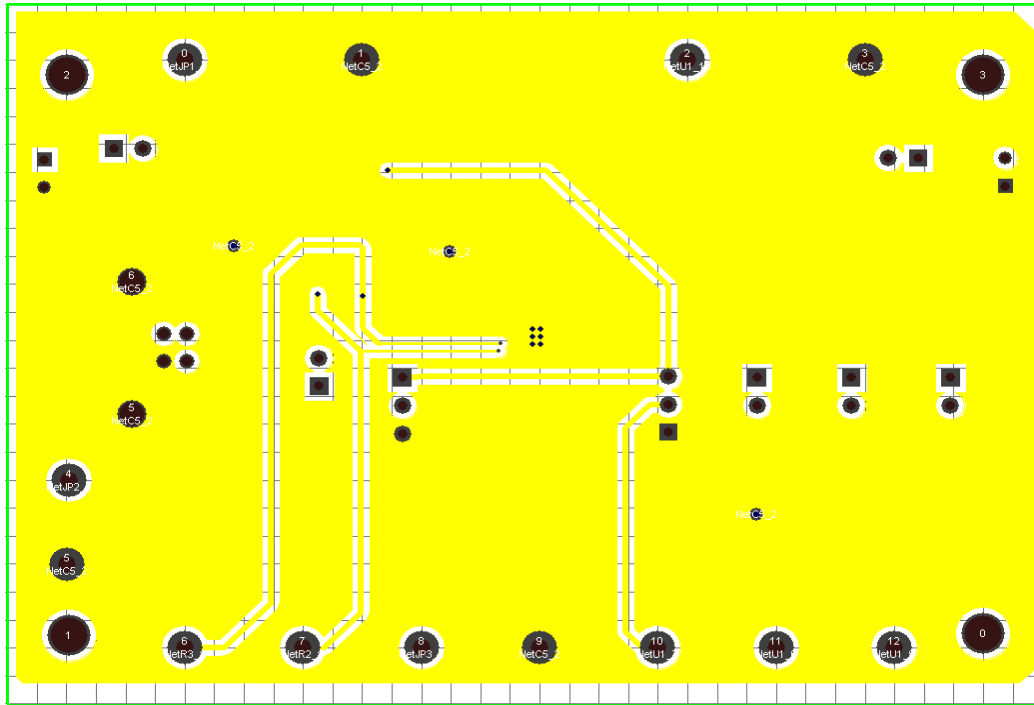

FIGURE 5. BOTTOM LAYER