

ISL9301EVAL1Z

Evaluation Board Application\Manual

AN1338
Rev 1.00
March 31, 2008

Description

The ISL9301EVAL1Z is an evaluation tool for the ISL9301 single-cell Li-ion battery charger. The evaluation tool provides a complete evaluation platform addressing all datasheet specifications and functionality. The jumpers on the board facilitate the programming of the charge current, different charging conditions, and can be used to make other necessary connections, such as current measurement.

The ISL9301 is a Li-ion battery charger with power path management function. It uses separate power paths to supply the system load and charge the battery. This feature allows the system to immediately operate with a completely discharged battery. This feature also allows the charge to terminate when the battery is full while continuing to supply the system with the input source, thus minimizes unnecessary charge/discharge cycles and improves the battery life.

The ISL9301 accepts input voltages ranging from 4.5V up to 28V. Due to the high voltage capability, the components associated with the input circuit on the evaluation board are good for a 28V supply.

The components assembled in the center square constitute a complete charger, indicating the space saving advantage of the typical ISL9301 installation in space-limited applications.

Key Features

- Complete Charger for Single-Cell Li-ion/Polymer Batteries
- Power Path Management Optimize Charge and System Currents
- Intelligent Timeout Interval Based On Actual Charge Current
- Integrated Disconnect Switch to Disconnect the Battery
- 30mV (target) Voltage Accuracy
- Programmable Charge Current
- Programmable End-of-Charge Current
- Charge Current Thermal Foldback for Thermal Protection
- Trickle Charge for Fully Discharged Batteries
- 28V Maximum Voltage at VIN pin
- Power Presence and Charge Indications
- Ambient Temperature Range: -40°C to +85°C
- 3x3 10 Ld DFN Package

What is Needed

The following instruments will be needed to perform testing:

- Power supplies:
 - PS1: DC 30V/2A
 - PS2: DC 0V to 5V, 1.5A
 - DC Electronic load: 20V/2A
- Multimeters
- Oscilloscope
- Cables and wires

Quick Setup Guide (Refer to Figure 1)

DO NOT APPLY POWER UNTIL STEP 6

- Step 1: Connect a 5V supply PS1 to VIN (J6, upper +) with the current limit set at 1A
- Step 2: Connect a 3.8V supply PS2 to BAT output (J2, upper +) with the current limit set at 1A
- Step 3: Connect a current meter to JP5 as shown in Figure 1
- Step 4: Connect the DC electronic load of 1.2A to BAT (J2, upper +)
- Step 5: Insert a jumper shunt on JP6, all other jumper shunts are not installed
- Step 6: Turn on Power Supplies and DC electronic load, adjust the power supply PS2 such that the voltmeter V2 reads 3.8V
- Step 7: Both the red and the green LEDs should be on, indicating power on and charging condition
- Step 8: The current meter I2 should read about 70mA as the charging current
- Step 9: Insert a jumper shunt on JP3 and the current meter I2 should read about 150mA charging current
- Step 10: Insert a jumper shunt on both JP2 and JP3, the current meter I2 should read about 220mA charging current
- Step 11: Reduce the voltage at PS2 to 2.4V for trickle charge currents. The current reading should be 25mA
- Step 12: Slowly reduce the E-Load1 current until the green LED turns off, the current meter I2 should read about 15mA EOC current
- Step 13: Insert a jumper shunt on JP1 and repeat Step 12, the current meter I2 should read 30mA EOC current
- Step 14: DPPM test. Set the current limit on the input supply to 1.5A. Increase E-Load2 output current until VOUT drops to VDPPM level of 4.3V due to input current limit of the ISL9301 and charging current to the battery will reduce; to allow more current to the output due to the DPPM function

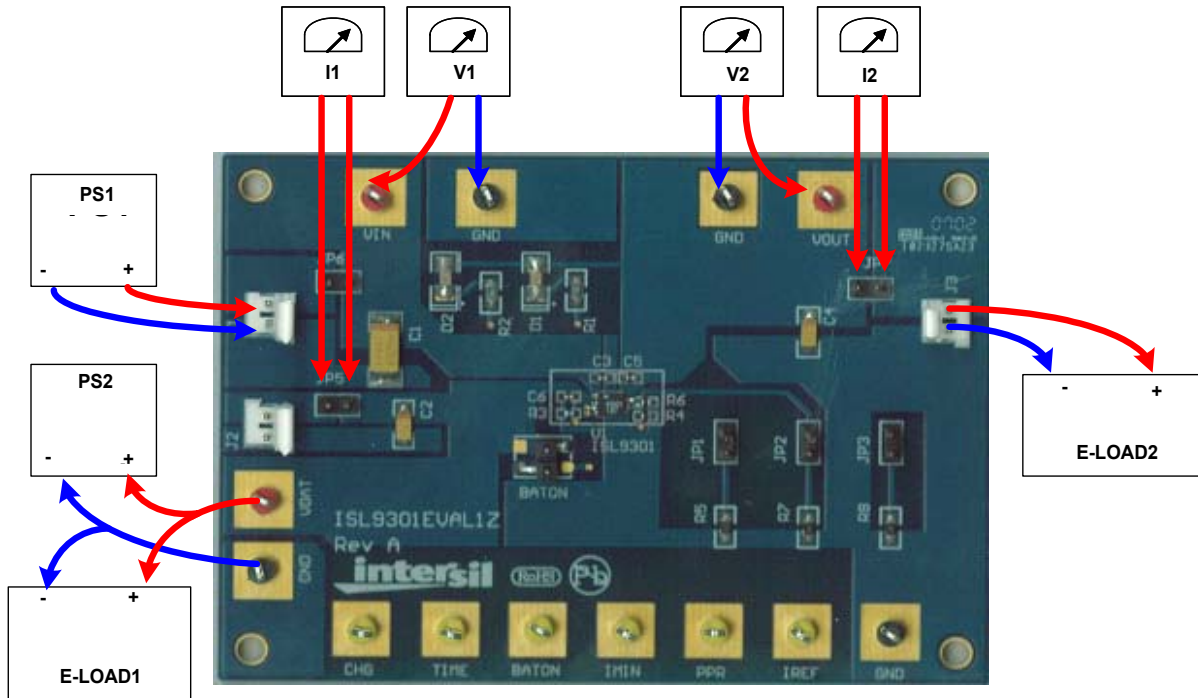

FIGURE 1. CONNECTION OF EQUIPMENT

Description of Jumper Settings

JP1 - Parallels an additional 274k resistor to the IMIN pin (total R_{IMIN} = 173k), such that the End-of-Charge Current will be increased to 30mA (R_{IMIN} is 274k and the EOC current is 15mA without the shunt).

JP2 - Parallels an additional 53.4k resistor to the IREF pin (total R_{IREF} = 26.7k), such that the charge current will be increased to 0.15A (R_{IREF} is 53.4k and the charge current is 70mA if the shunt on JP3 is removed).

JP3 - Parallels an additional 53.4k resistor to the IREF pin (total R_{IREF} = 26.7k), such that the charge current will be increased to 0.15A (R_{IREF} is 53.4k and the charge current is 70mA if the shunts on both JP2 is removed). Shunts JP2 and JP3 are installed, such that two additional 53.4k resistor to IREF pin (total R_{IREF} = 17.8k), the charge current will be increased to 0.24A.

JP5 - A shunt installed on JP5 connects the BAT pin to the output connector J2 if IBAT measurement is not needed. The shunt can be replaced by a current meter if charge current measurement is needed as shown in Figure 1.

JP6 - A shunt installed on JP6 connects the VIN pin to the output connector J1 if output current measurement is not needed. The shunt can be replaced by a current meter if input current measurement is needed as shown in Figure 1.

JP7 - A shunt installed on JP7 connects the VOUT pin to the output connector J3 if input current measurement is not needed. The shunt can be replaced by a current meter if

output current measurement is needed as shown in Figure 1.

JP8 - A shunt installed on JP8 connects BATON pin to VBAT such that VOUT is connected to VBAT through an internal MOSFET when VIN is not applied. When VIN is applied, BATON pin has no impact on VOUT and VBAT.

TABLE 1. JUMPER SETTING SUMMARY

JUMPER	POSITION	FUNCTION
JP1	Shunt installed	Set EOC current to 30mA
JP2	Shunt installed	Sets charging current to 0.15A, if shunt on JP3 is not installed
JP3	Shunt installed	Sets charging current to 0.15A, if shunt on JP2 is not installed
JP5	Shunt installed	Connects BAT to J2
JP6	Shunt installed	Connects VIN to J1
JP7	Shunt installed	Connects VOUT to J3
JP8	Shunt installed	Connects VOUT to VBAT when VIN is not applied.

Schematic

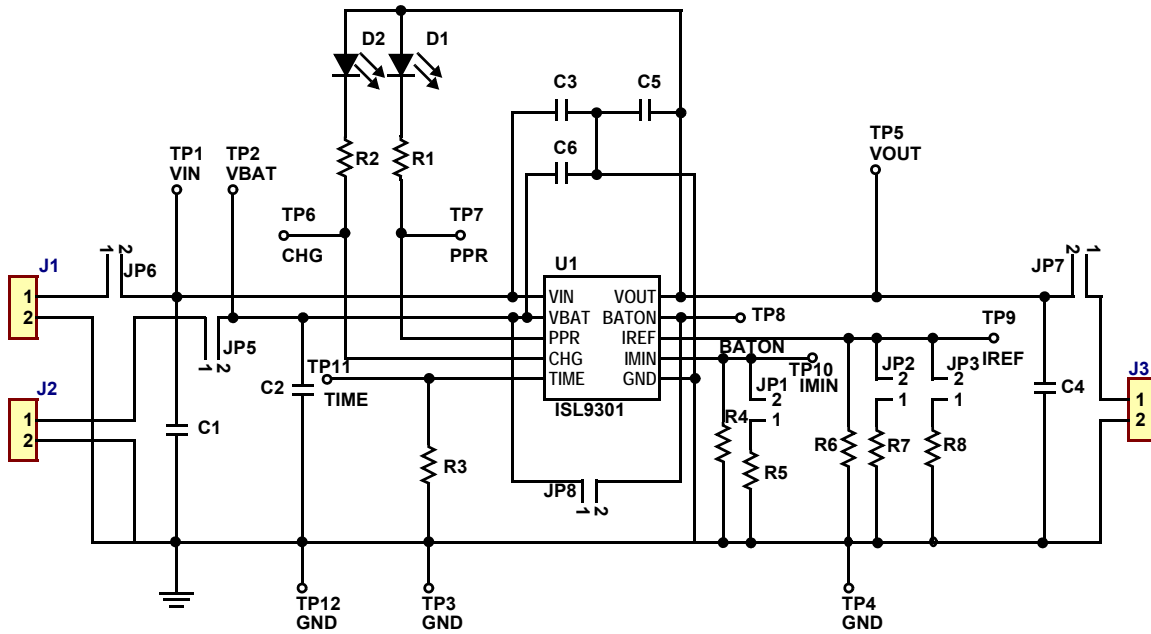

FIGURE 2. ISL9301EVAL1Z SCHEMATIC

PCB Layout

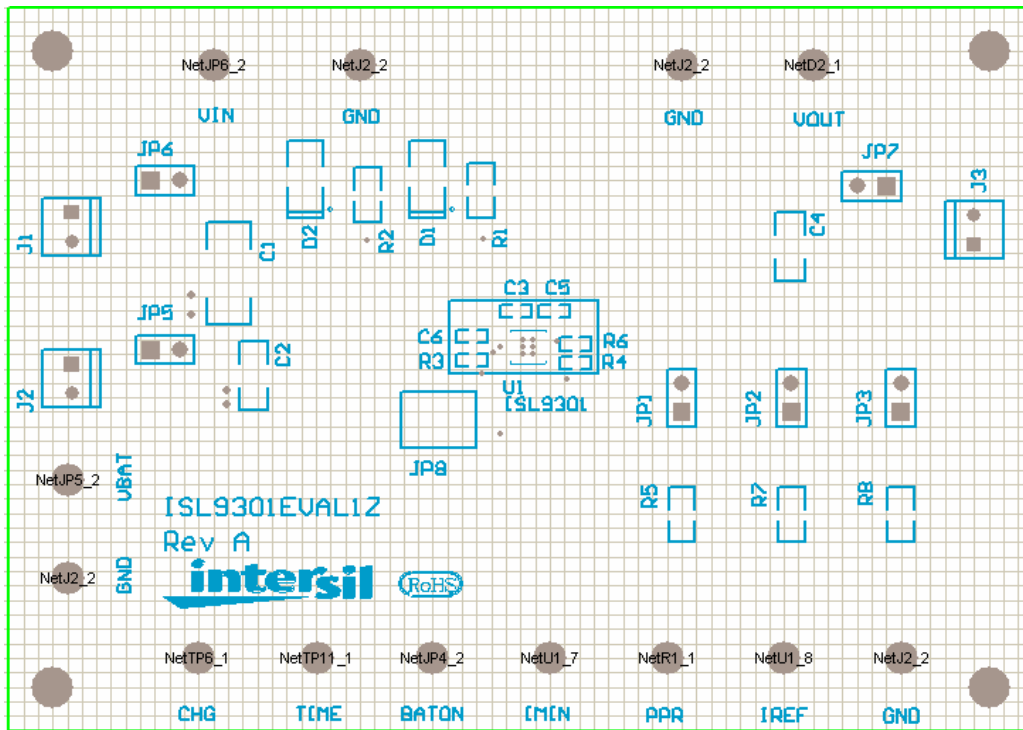

FIGURE 3. SILK LAYER

PCB Layout (Continued)

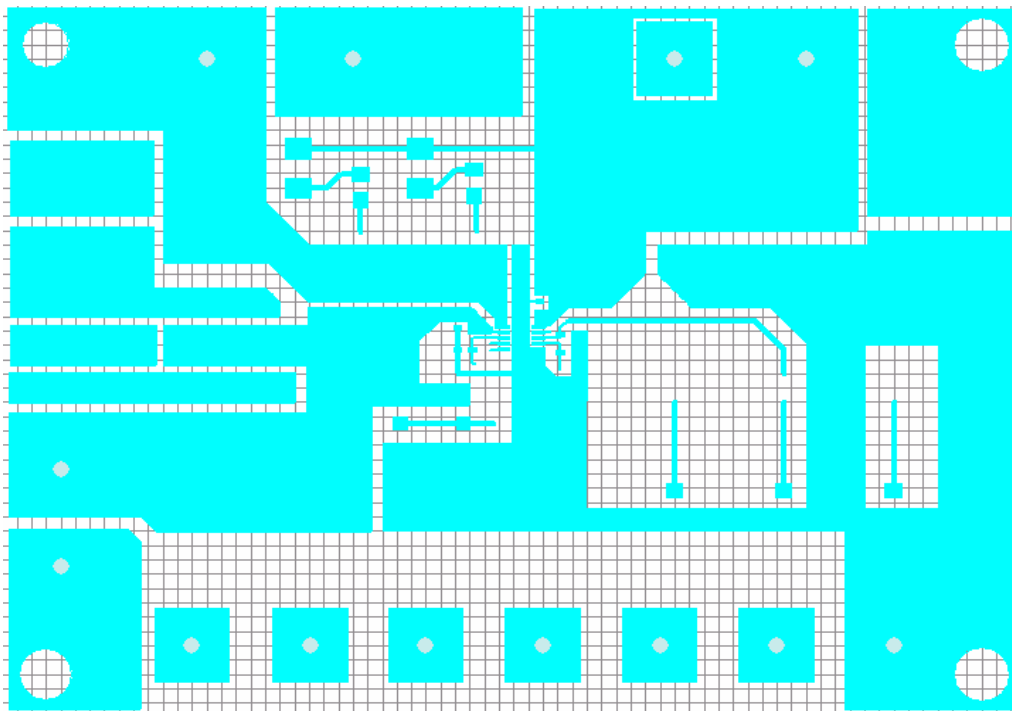

FIGURE 4. TOP LAYER

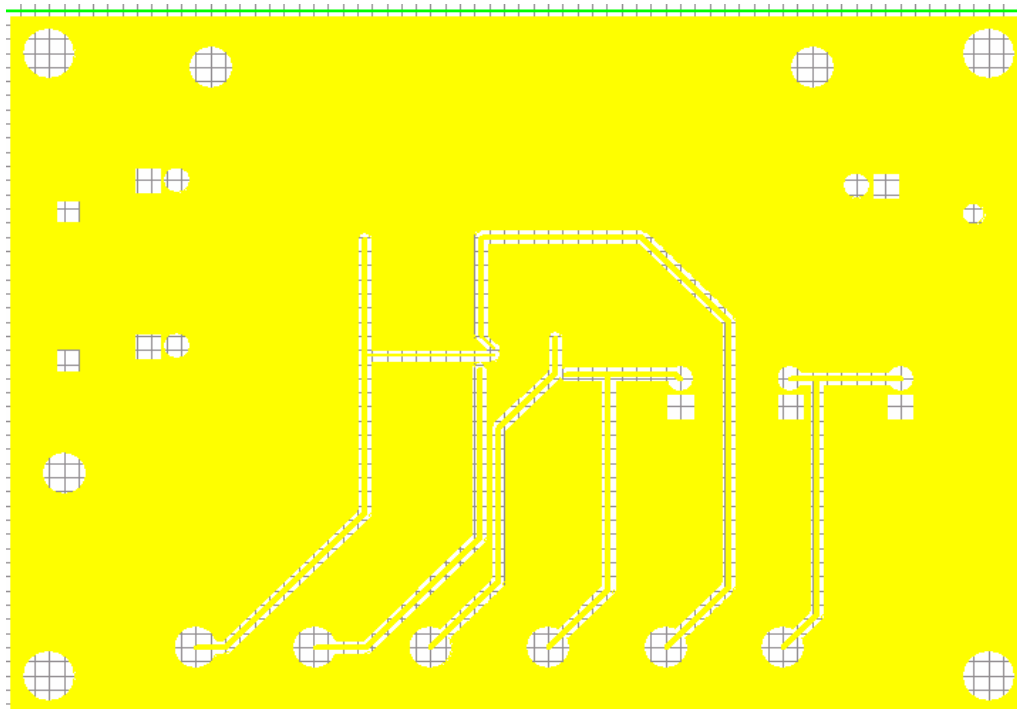

FIGURE 5. BOTTOM LAYER

ISL9301EVAL1Z Bill Of Materials

ITEM	QTY	REFERENCE	PART DESCRIPTION	PCB FOOTPRINT	PART NUMBER	VENDOR
1	1	U1	ISL9301 Power Pather Charger	3x3 DFN	ISL9301	Intersil
2	2	R1, R2	0805, 470, 5% Resistor	0805	ERJ-6GEYJ471V	Panasonic
3	1	R3	0402, 100k, 1% Resistor	0402	ERJ-2RKF1003X	Panasonic
4	1	R4	0402, 274k, 1% Resistor	0402	ERJ-2RKF2743X	Panasonic
5	1	R6	0402, 53.4k, 1% Resistor	0402	ERJ-2RKF5902X	Panasonic
6	1	R5	0805, 274k, 1% Resistor	0805	ERJ-6ENF2743V	Panasonic
7	2	R7, R8	0805, 53.4k, 1% Resistor	0805	ERJ-6ENF5902V	Panasonic
8	1	C1	4.7 μ F, 35V, Tantalum	2512	ECS-T1VC475R	Panasonic
9	3	C3, C5, C6	0.01 μ F, 50V, X7R Ceramic	0402	C0402C103K5RACTU	Kemet
10	2	C2, C4	10 μ F, 6.3V, Tantalum	1206	ECS-T0JY106R	Panasonic
11	3	J1, J2, J3	2.54mm Center Header, 2ckt		22-11-2022	Molex
12	3	VIN, VOUT, VBAT	Test point, Red		5010	Keystone
13	6	TIME, CHG, PPR, IREF, IMIN, BATON	Test point, Yellow		5014	Keystone
14	4	GND	Test point, Black		5011	Keystone
15	5	JP2, JP3, JP5, JP6, JP7, JP8	2.54mm header, 2ckt		22-28-4020	Molex
16	1	D2	Green LED	0805	SML-LXT0805GW-TR	Lumex Opto
17	1	D1	Red LED	0805	SML-LXT0805IW-TR	Lumex Opto