

ISL97519AIUZEVALZ

AN1645
Rev.1.00
Mar 3, 2022

Description

The ISL97519AIUZEVALZ evaluation board is an evaluation kit for evaluating the ISL97519AIUZEVALZ, a step-up voltage regulator that operates with high frequency and high efficiency. This evaluation kit is designed to deliver over 90% efficiency.

The ISL97519AIUZEVALZ kit provides a dip switch that allows users to select either 600kHz or 1.2MHz switching frequency.

Key Features

- A Complete Evaluation Platform for Evaluation of ISL97519A
- Input Voltage: 2.3V to 5.5V
- Proven Evaluation Board Layout
- Pb-free (RoHS Compliant)

Pin Configuration

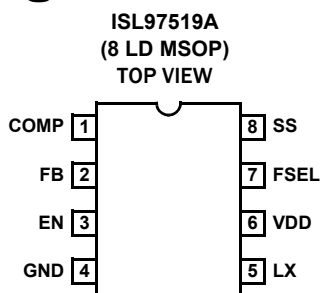

Ordering Information

PART #	DESCRIPTION
ISL97519AIUZEVALZ	Evaluation Board for ISL97519A

Quick Setup Guide

- Step 1:** Connect the power supply between the headers of VIN and GND. The positive output of the power supply should be connected to the VIN header. Set the power supply voltage between 2.3V and 5V, and the current limit at 3A.
- Step 2:** Connect the E-load between the headers of VOUT and GND. The positive input of the E-load should be connected to the VOUT header. Set the E-load current. The load current should not exceed the maximum output current that the part can supply.
- Step 3:** Close pins 1 and 4 of S1 to tie the FSEL pin to VIN. This will set the switching frequency to 1.2MHz. Open pins 1 and 4 to pull FSEL to ground with R4 to set the frequency to 600kHz.
- Step 4:** Close pins 2 and 3 of S1 to tie the EN pin to VIN in order to enable the part. To disable the part, open pins 2 and 3 in order to pull EN to ground with R3 to disable the part.

Make sure all the connections on the evaluation board are correct, then turn on the power supply and E-load. The part will start to operate.

Maximum Output Current

The MOSFET current limit is normally 2.0A and guaranteed at 1.7A. This restricts the maximum output current that the ISL97519A can drive. Table 1 shows the ISL97519AIUZEVALZ maximum output current, $I_{O\text{MAX}}$ at different input and output voltages.

TABLE 1. TYPICAL MAXIMUM OUTPUT CURRENT

V_{IN} (V)	V_{OUT} (V)	$I_{\text{O\text{MAX}}}$ (mA)
2.5	5	870
2.5	9	500
2.5	12	380
3.3	5	1150
3.3	9	655
3.3	12	500
5	9	990
5	12	750

Board Design Schematic

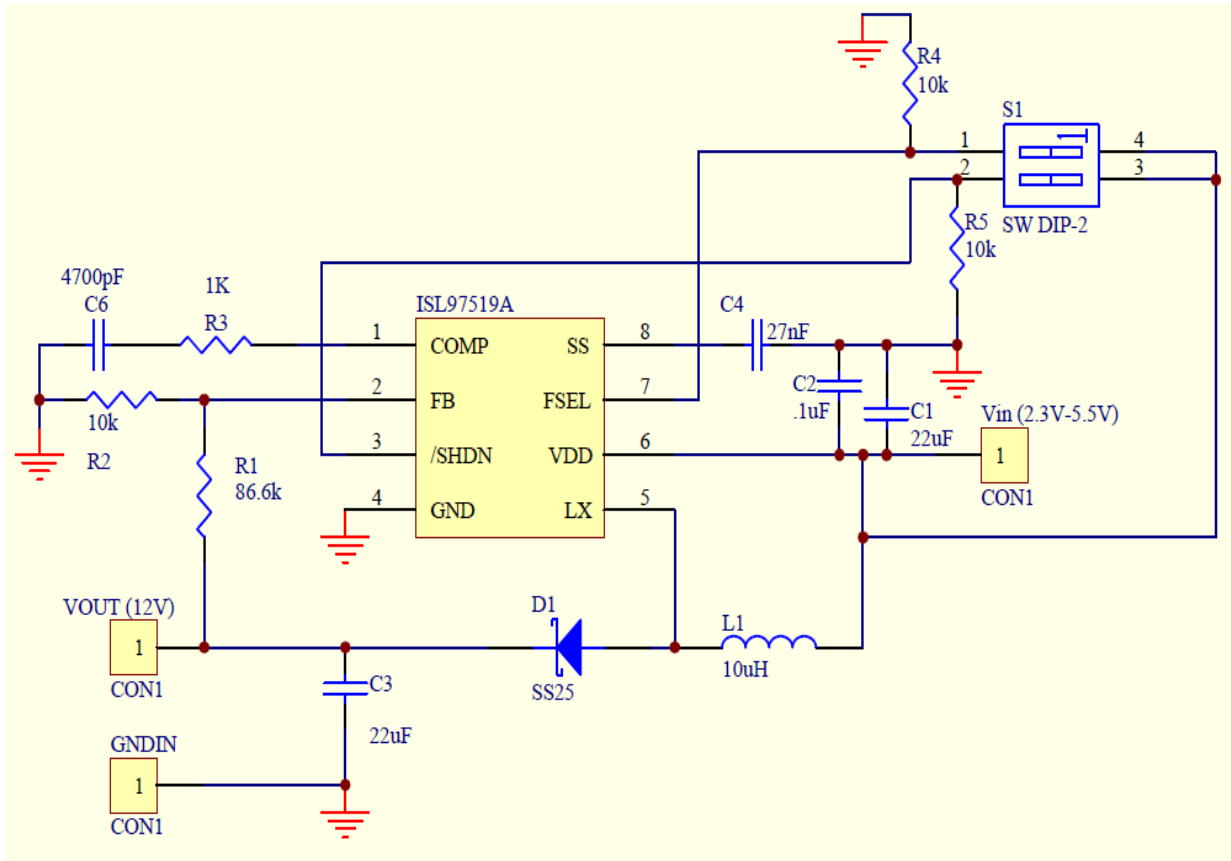

FIGURE 1. SCHEMATIC

Evaluation Board Layout

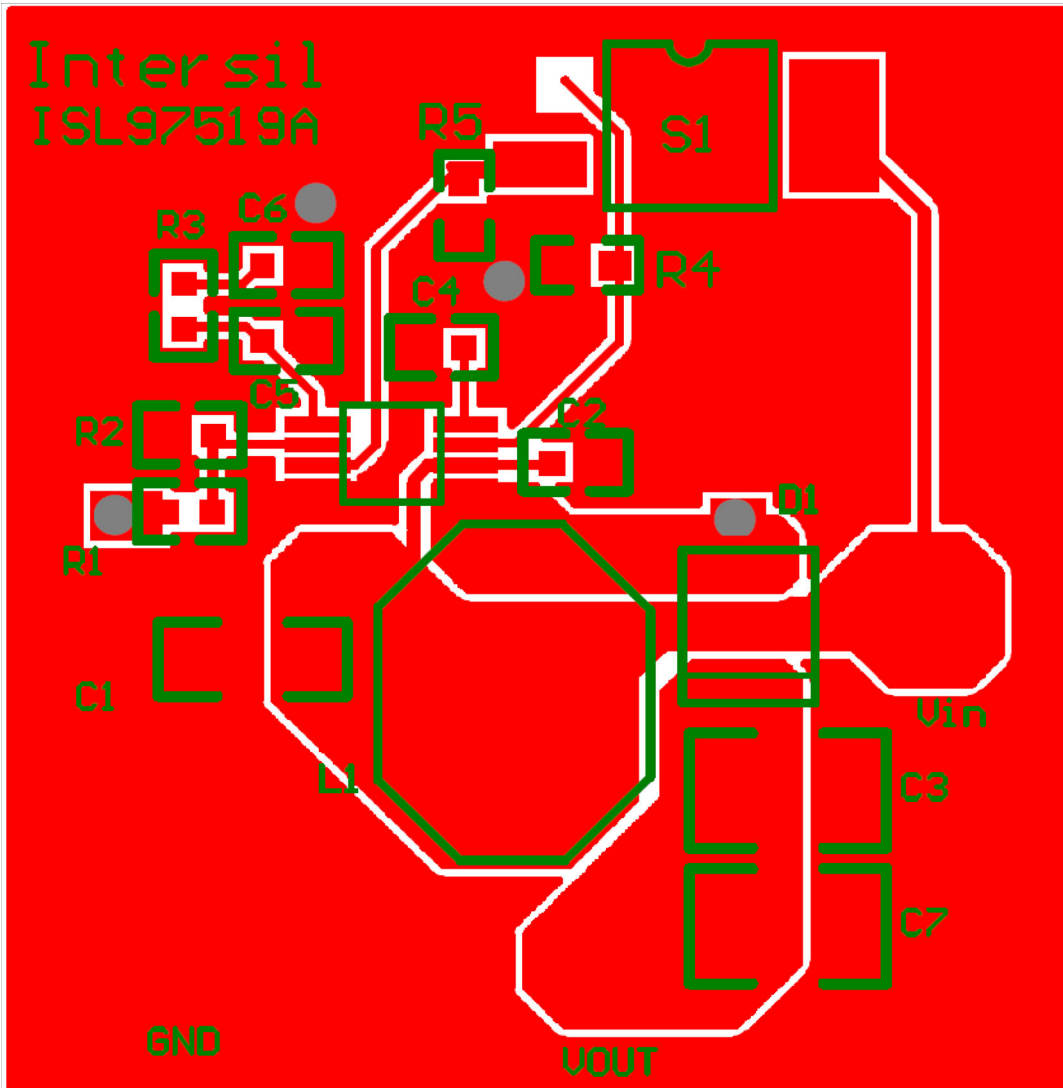

FIGURE 2. EVB ASSEMBLY LAYER

Evaluation Board Layout (Continued)

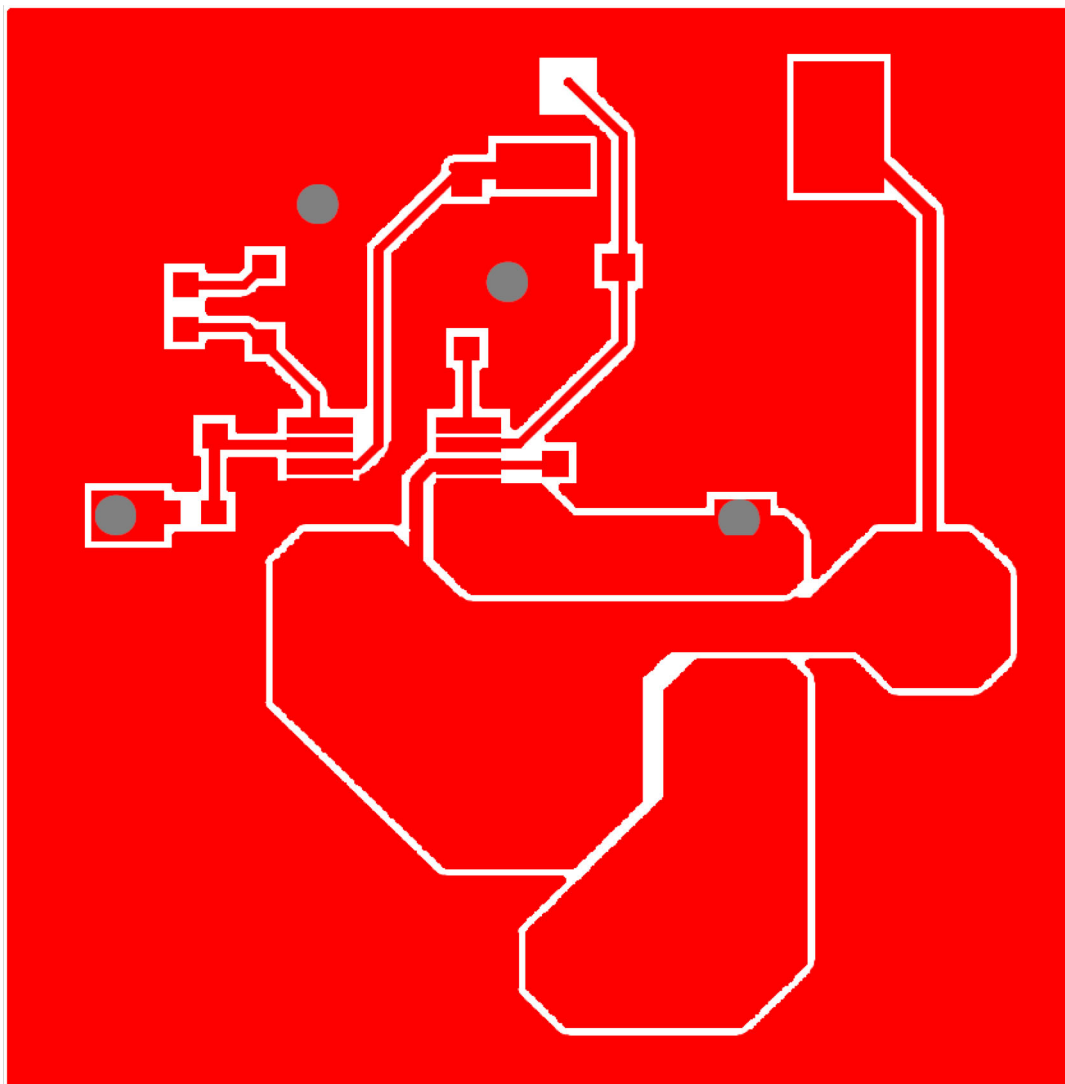

FIGURE 3. TOP LAYER

Evaluation Board Layout (Continued)

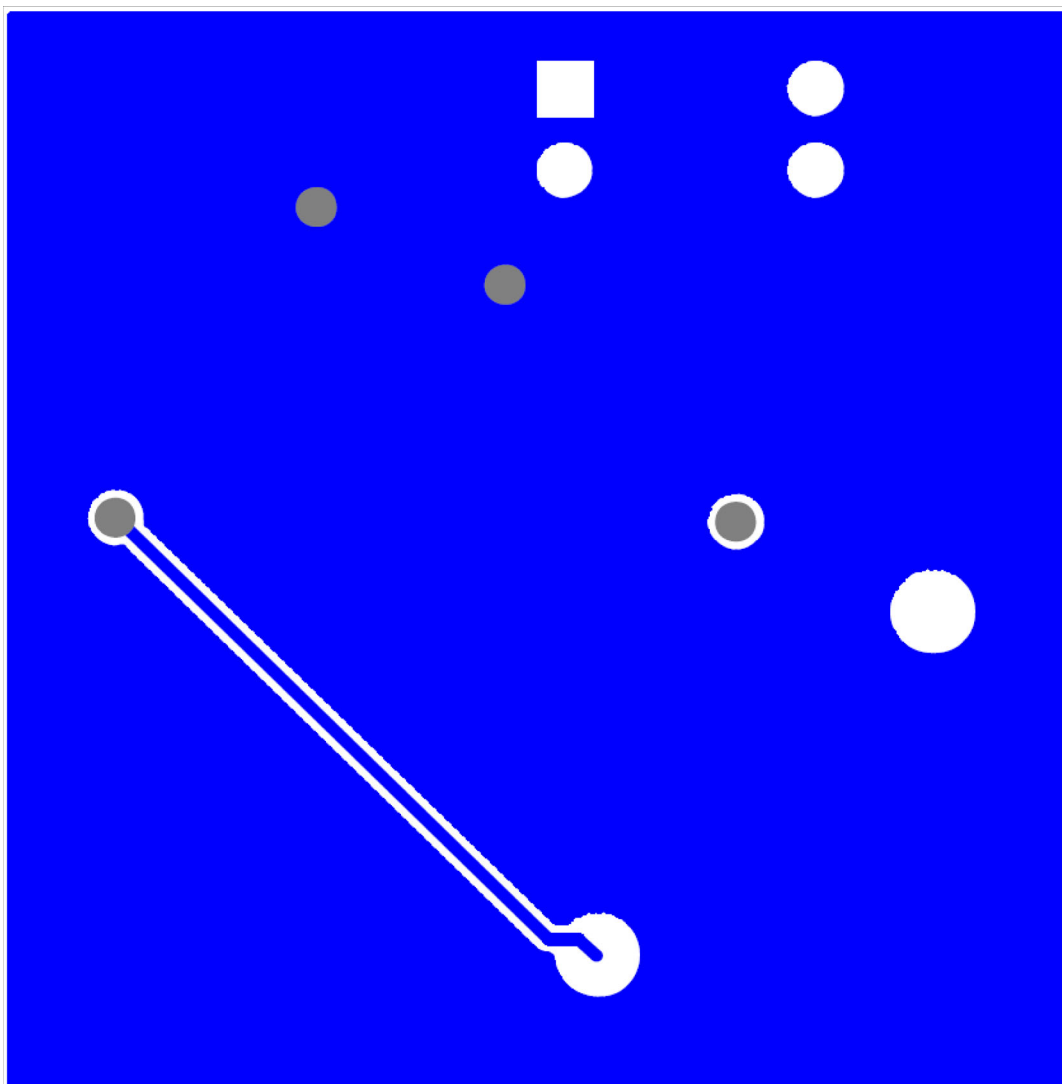

FIGURE 4. BOTTOM LAYER

TABLE 2. ISL97519AIUZEVALZ BILL OF MATERIALS (BOM)

ITEM	QTY	REFERENCE	PART DESCRIPTION	PCB FOOTPRINT	PART NUMBER	VENDOR
1	1	C4	27nF	603		TDK
2	1	C6	4700nF	603		TDK
3	1	C2	0.1μF/16V	603	C1068X7R1H104K	TDK
4	1	R1	86.6k	603		WALSIN
5	3	R2, R4, R5	10k	603	WR06W1002JTL	WALSIN
6	1	R3	1k	603		
8	1	C3	22μF	1206		MURATA
9	1	C1	22μF	1206	GRM31CR61C226KE15L	MURATA
10	1	L1	10μF	CDRH8D43	CDRH8D43NP-100NC	SUMIDA
11	1	U1	ISL97519A	MSOP-8	ISL97519A	INTERSIL
12	1	VOUT (12V)	CON1	Powerpost		
13	1	VIN (3.3V)	CON1	Powerpost		
14	1	GND IN	CON1	Powerpost		
15	1	D1	SS25	DO-214A	SS25	Fairchild
16	1	S1	SWDIP-2	DIP4		CKN3001-ND

Revision History

DATE	REVISION	CHANGE
Mar 3, 2022	1.00	Corrected BOM information. Updated Ordering part number throughout.
Jul 1, 2011	0.00	Initial Release