

ISL97656IRTZEVALZ

Evaluation Board

AN1473
Rev 1.00
May 10, 2010

The ISL97656IRTZEVALZ is an evaluation kit for evaluating the ISL97656, a step-up voltage regulator that operates with high frequency and high efficiency. This evaluation kit is designed to deliver up to 2A output current for portable equipment and TFT-LCD display.

The ISL97656IRTZEVALZ evaluation kit provides a dip switch that allows users to select either 620kHz or 1.2MHz frequency.

Key Features

- A Complete Evaluation Platform for the ISL97656 Evaluation
- Input Voltage: 2.3V to 5.5V
- Proven Evaluation Board Layout
- Pb-Free (RoHS Compliant)

What is Needed

The following instruments will be needed to perform testing:

- Power Supplies
- DC Electronic Load
- Multimeters
- Oscilloscope
- Cables and Wires

Pinout

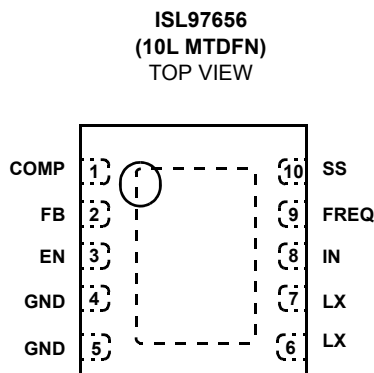

Quick Setup Guide

1. Connect power supply between headers of V_{IN} and V_{IN_GND} . The positive output of the power supply should be connected to V_{IN} header. Set power supply voltage between 2.3V and 5V, and current limit at 4A.
2. Connect E-load between headers of V_{OUT} and OUT_GND . The positive input of the E-load should be connected to V_{OUT} header. Set E-load current. The load current should not exceed the maximum output current in Table 1.
3. Close pins 1 and 4 of S1 to tie FREQ pin to V_{IN} to set 1.25MHz switching frequency. Open pins 1 and 4 to pull FREQ to ground with R_4 to set 620kHz.
4. Close pins 2 and 3 of S1 to tie EN pin to V_{IN} to enable the part. Open pins 2 and 3 to pull EN to ground with R_3 to disable the part.
5. Make sure all the connections on the evaluation board are correct, then turn on power supply and E-load. The part starts to operate.

Maximum Output Current

The MOSFET current limit is normally 4A and guaranteed 3.8A. This restricts the maximum output current that the ISL97656 can drive. Table 1 shows typical maximum I_{OUT} values for 1.2MHz switching frequency and 10 μ H inductor.

TABLE 1. TYPICAL MAXIMUM I_{OUT} VALUES

V_{IN} (V)	V_{OUT} (V)	I_{OMAX} (mA)
2.5	5	1790
2.5	9	990
2.5	12	750
3.3	5	2370
3.3	9	1300
3.3	12	970
5	9	1970
5	12	1470

Ordering Information

PART NUMBER	DESCRIPTION
ISL97656IRTZEVALZ	Evaluation Board for ISL97656

Board Design Schematic

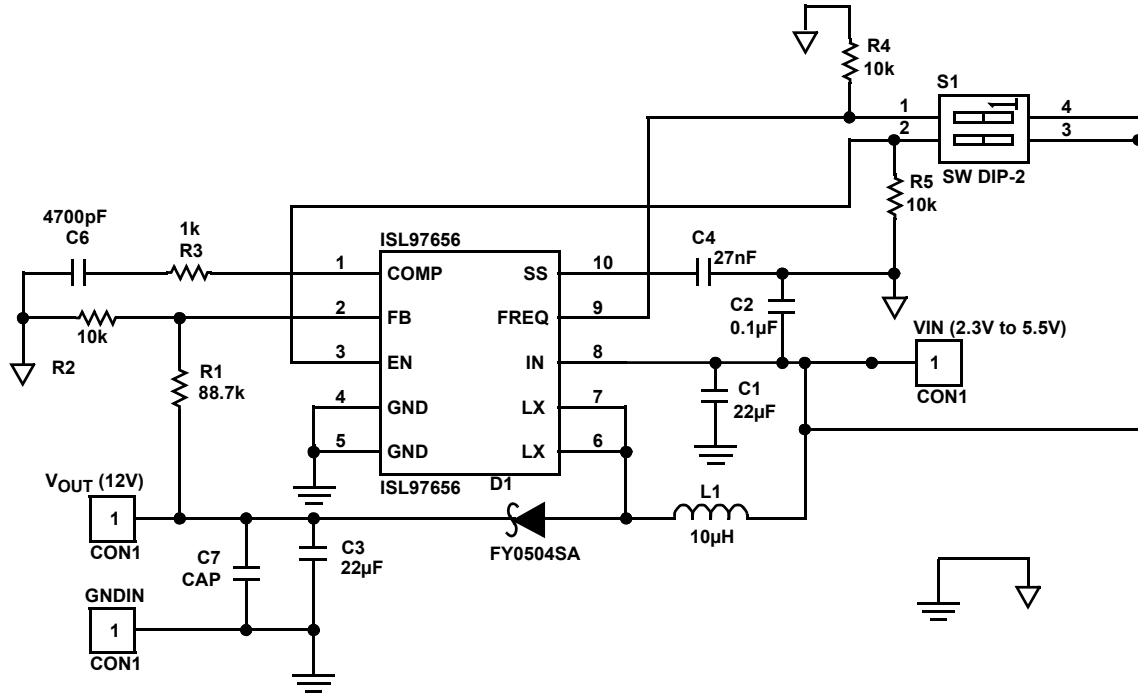

NOTE: The thermal pad should connect to signal ground. Both grounds should connect at pins 4 and 5.

FIGURE 1. SCHEMATIC

TABLE 2. ISL97656IRTZEVALZ BILL OF MATERIALS (BOM)

ITEM	QTY	REFERENCE	PART DESCRIPTION	PCB FOOTPRINT	PART NUMBER	VENDOR
1	1	C4	27nF	603		TDK
2	1	C6	4700pF	603		TDK
3	1	C2	0.1µF/16V	603	C1068X7R1H104K	TDK
4	1	R1	88.7k	603		WALSIN
5	3	R2, R4, R5	10k	603	WR06W1002JTL	WALSIN
6	1	R3	1k	603		
8	1	C3	22µF	1206	GRM31CR61C226KE15L	MURATA
9	1	C1	22µF	1206	GRM31CR61C226KE15L	MURATA
10	1	L1	10µH	SLF12575	SLF12575T-100M5R4-PF	TDK
11	1	U1	IC	TDFN-10	ISL97656	INTERSIL
12	OPEN	C7	CAP			
13	1	VOUT (12V)	CON1	Powerpost		
14	1	VIN (2.3V to 5.5V)	CON1	Powerpost		
15	1	GNDIN	CON1	Powerpost		
16	1	D1	FYD054SA	DPAK	FYD0504SATM	Fairchild
17	1	ISL97656	ISL97656	TDFN-10		INTERSIL
18	1	S1	SW DIP-2	DIP4		CKN3001-ND

PCB Layout

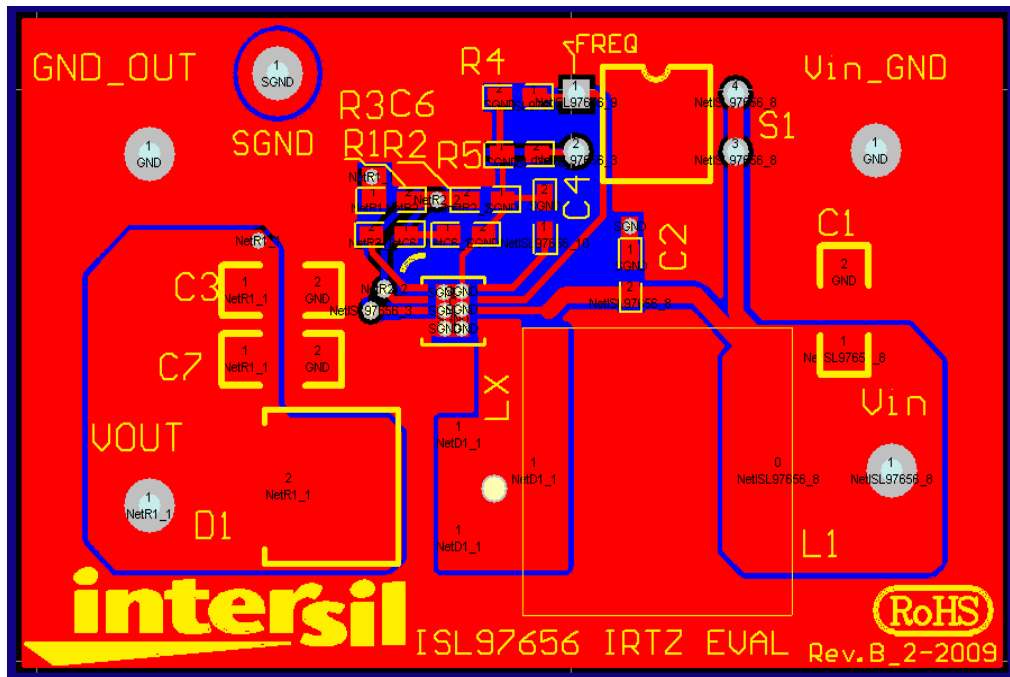

FIGURE 1. EVALUATION BOARD ASSEMBLY LAYER

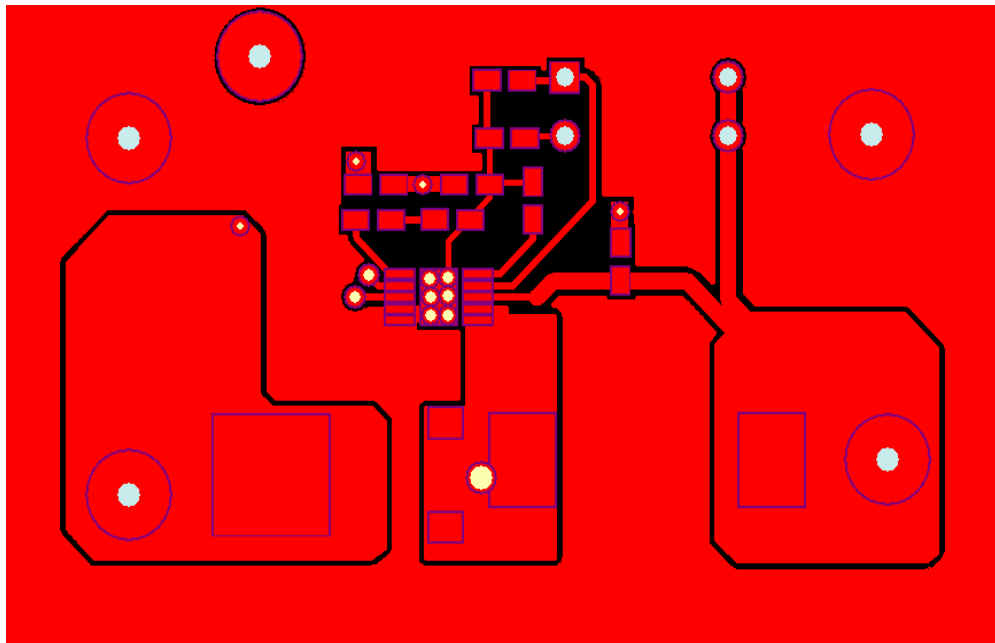

FIGURE 2. TOP LAYER

PCB Layout (Continued)

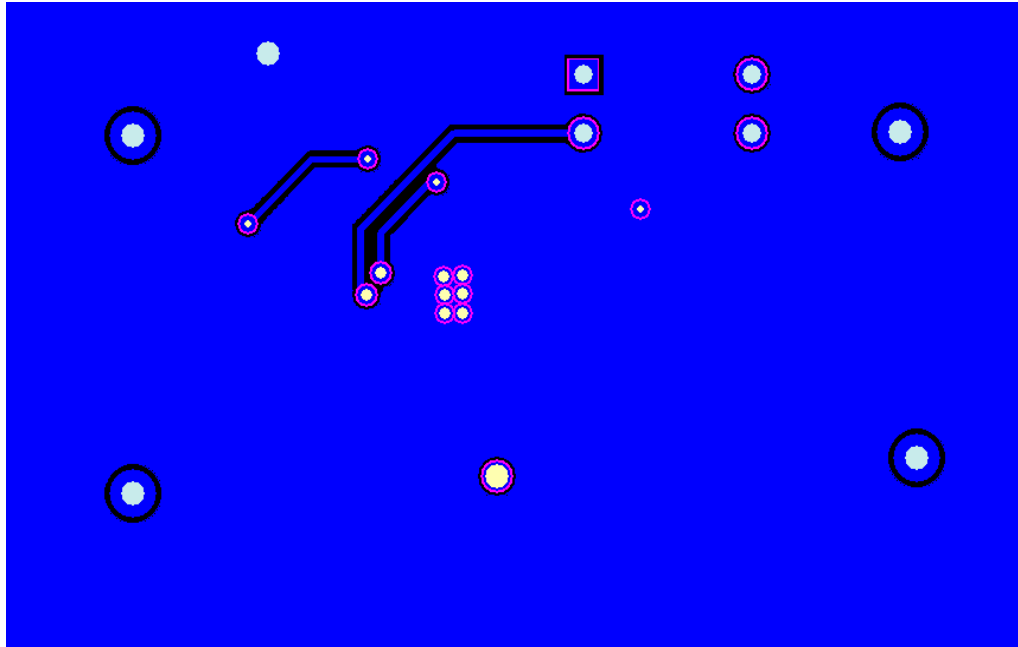

FIGURE 3. BOTTOM LAYER