

Features

- Precision reference, error amplifier, and a high voltage Darlington transistor in a single package
- 1.299V±1% reference @25°C (±1.5% @-40°C to 85°C)
- Error amplifier supply voltage range: 1.3V to 12.5V over temperature
- Breakdown voltage of Darlington transistor: 350V

Applications

- LED lamps
- Low voltage power supply feedback
- AC-to-DC off-line power supplies
- DC-to-DC converters

Description

The IX9915 integrates an error amplifier with a precision reference and a 350V Darlington transistor in a single package. The error amplifier can be operated from 1.3V to 12.5V over the operational temperature range. The breakdown voltage of the Darlington transistor is 350V.

The integrated combination of a 4-terminal 431 type shunt regulator with a high voltage Darlington transistor is ideal for use in LED lamp bleeder control circuits.

Ordering Information

Part	Description
IX9915N	8-pin SOIC, Tube (100/Tube)
IX9915NTR	8-pin SOIC, Tape & Reel (2000/Reel)

IX9915 Block Diagram

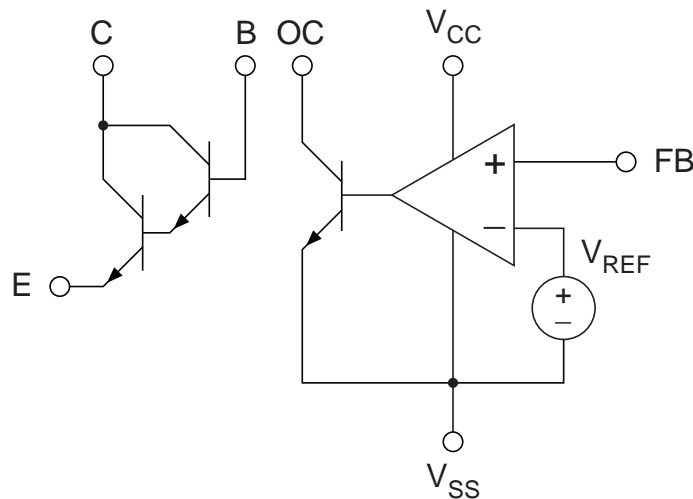

1. Specifications	3
1.1 Package Pinout	3
1.2 Pin Description	3
1.3 Absolute Maximum Ratings	3
1.4 Electrical Characteristics	4
1.5 Test Diagrams	4
1.6 Performance Data	6
2. Functional Description	7
2.1 Regulation Voltage	7
2.2 Compensation	8
2.3 Design Example	8
3. Manufacturing Information	9
3.1 Moisture Sensitivity	9
3.2 ESD Sensitivity	9
3.3 Soldering Profile	9
3.4 Board Wash	9
3.5 Mechanical Dimensions	10

1. Specifications

1.1 Package Pinout

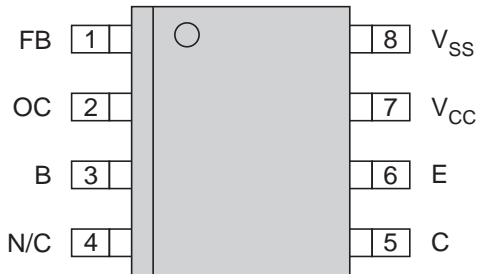

1.2 Pin Description

Pin#	Name	Description
1	FB	Input Voltage
2	OC	Output Current
3	B	Darlington Base
4	N/C	Not Connected
5	C	Darlington Collector
6	E	Darlington Emitter
7	V _{CC}	Supply Input
8	V _{SS}	Supply Return

1.3 Absolute Maximum Ratings

Parameter	Symbol	Ratings	Unit
Collector-Emitter Voltage	V _{CEO}	350	V
Emitter-Collector Voltage	V _{ECO}	2	V
Collector Current	I _{CE}	200	mA
Supply Voltage (Referenced to V _{SS})	V _{CC}	15	V
Output DC Current	I _{OC}	20	mA
Power Dissipation (Shunt Regulator)	P _A	30	mW
Power Dissipation, Darlington Transistor ¹	P _D	250	mW
Total Power Dissipation ¹	P _T	250	mW
ESD Rating (Human Body Model)	-	2	kV
Operating Temperature	T _{OPR}	-40 to +85	°C
Storage Temperature	T _{STG}	-55 to +130	°C

¹ Derate linearly 2.83 mW/°C.

Unless otherwise specified, Absolute Maximum electrical ratings are at 25°C.

Absolute Maximum Ratings are stress ratings. Stresses in excess of these ratings can cause permanent damage to the device. Functional operation of the device at these or any other conditions beyond those indicated in the operational sections of this data sheet is not implied.

Typical values are characteristic of the device at 25°C, and are the result of engineering evaluations. They are provided for information purposes only, and are not part of the manufacturing testing requirements.

1.4 Electrical Characteristics

Parameter	Symbol	Conditions	Min	Typ	Max	Unit
Input Characteristics @25°C (Unless Otherwise Specified)						
Supply voltage	V_{CC}	$T_A=-40^{\circ}\text{C to }+85^{\circ}\text{C}$	1.3	-	12.5	V
Reference voltage ¹	V_{REF}	$V_{CC}=1.6\text{V}, I_{OC}=10\text{mA}$ (Fig. 1)				V
		$T_A=25^{\circ}\text{C}$	1.286	1.299	1.312	
		$T_A=-40^{\circ}\text{C to }+85^{\circ}\text{C}$	1.280	1.299	1.318	
Deviation of V_{REF} over temperature ²	$V_{REF(DEV)}$	$V_{CC}=1.6\text{V}, I_{OC}=10\text{mA}, T_A=-40^{\circ}\text{C to }+85^{\circ}\text{C}$ (Fig. 1)	-	8	21	mV
Ratio of V_{REF} variation to V_{CC} change	$\Delta V_{REF}/\Delta V_{CC}$	$1.3\text{V} \leq V_{CC} \leq 12.5\text{V}, I_{OC}=10\text{mA}$ (Fig. 1)	-	-0.37	-2.7	mV/V
FB input bias current	I_{IB}	$V_{CC}=1.6\text{V}, I_{OC}=10\text{mA}$ (Fig. 1)	0.1	0.34	0.5	μA
Deviation of I_{IB} over temperature ²	$I_{IB(DEV)}$	$V_{CC}=1.6\text{V}, I_{OC}=10\text{mA}$, (Fig. 1) $T_A=-40^{\circ}\text{C to }+85^{\circ}\text{C}$	-	0.4	0.6	μA
Quiescent bias current	I_Q	$V_{CC}=1.6\text{V}, V_{FB} = V_{REF}, I_{OC}=0\text{mA}$ (Fig. 3)	-	75	100	μA
Error amplifier Off-State current	$I_{CC(off)}$	$V_{OC}=V_{CC}=12.5\text{V}, V_{FB}=0\text{V}$ (Fig. 2)		0.001	0.1	μA
Shunt Transconductance ³	$g_m (\Delta I_{OC}/\Delta V_{FB})$	$V_{CC}=1.6\text{V}, I_{OC} = 0.2\text{mA to }10\text{mA}, f=1\text{kHz}$	-	1	-	S
Darlington Characteristics @25°C (Unless Otherwise Specified)						
Collector-emitter voltage breakdown	BV_{CEO}	$I_{CE}=100\mu\text{A}$	350	-	-	V
Collector current	I_{CE}	$V_{CE}=200\text{V}, R_B=1\text{M}\Omega$ (Fig. 4)	-	-	100	nA
Base-emitter On voltage	$V_{BE(ON)}$	$I_{CE}=40\text{mA}, V_{CE}=2\text{V}$	-	-	1.8	V
Collector-emitter saturation voltage	$V_{CE(SAT)}$	$I_C=100\text{mA}, I_B=150\mu\text{A}$	-	-	1.2	V
Current gain	h_{FE}	$I_{CE}=40\text{mA}, V_{CE}=2\text{V}$	2500	-	40000	-

1 Reference voltage measured at Pin FB under the specified conditions.

2 Deviation parameters $V_{REF(DEV)}$ and $I_{IB(DEV)}$ are defined as the difference between the minimum and maximum values obtained over the rated temperature range.

3 With two external resistors, the total shunt transconductance of the circuit is defined as: $g'_m = \frac{g_m}{1 + \frac{R_1}{R_2}}$

1.5 Test Diagrams

Figure 1: $V_{REF}, I_{IB}, \Delta V_{REF}/\Delta V_{CC}, g_m$ Test Circuit

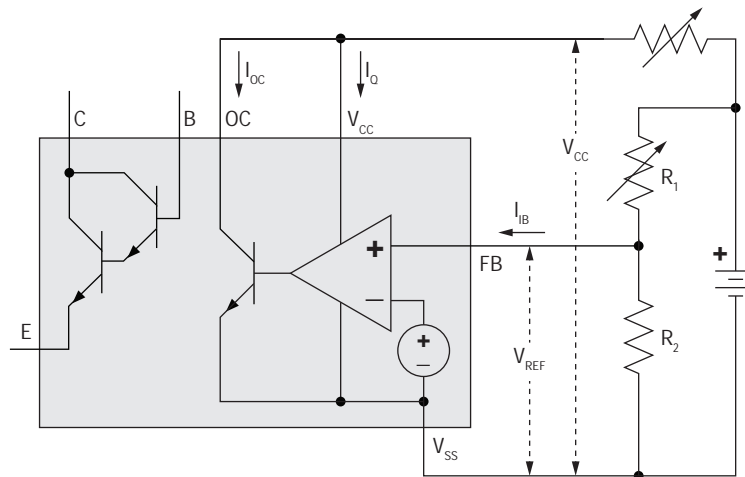

Figure 2: $I_{CC(OFF)}$ Test Circuit

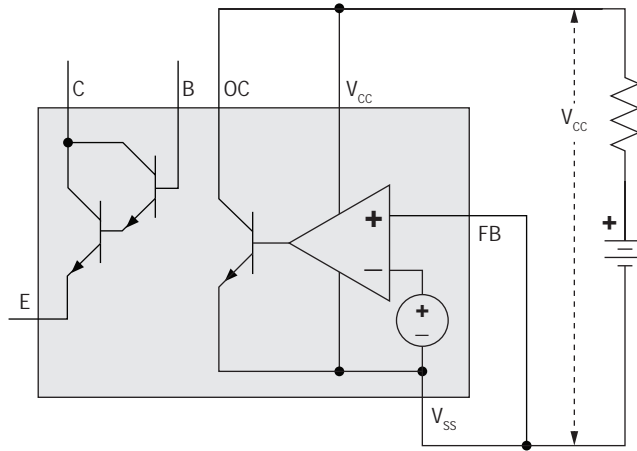

Figure 3: I_Q Test Circuit

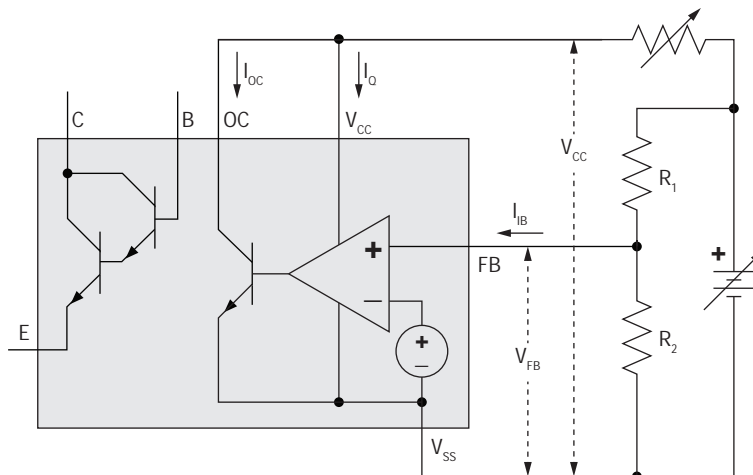
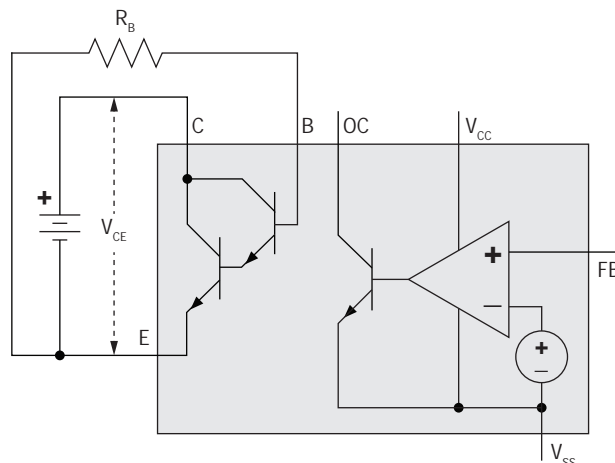
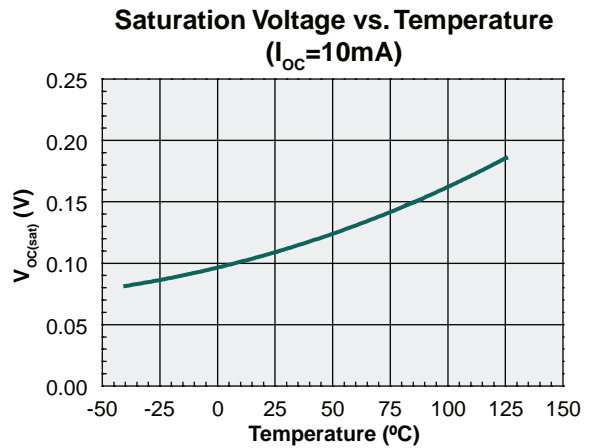
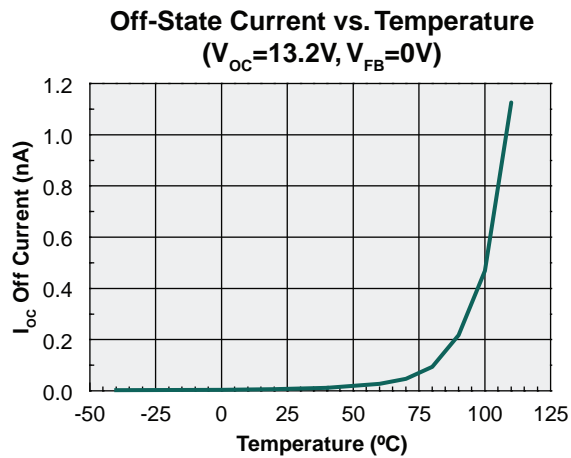
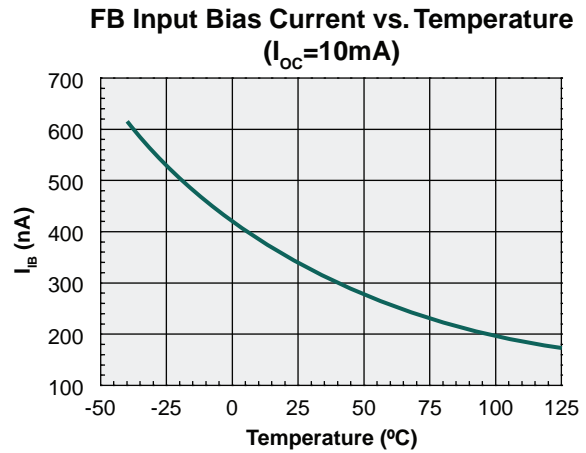
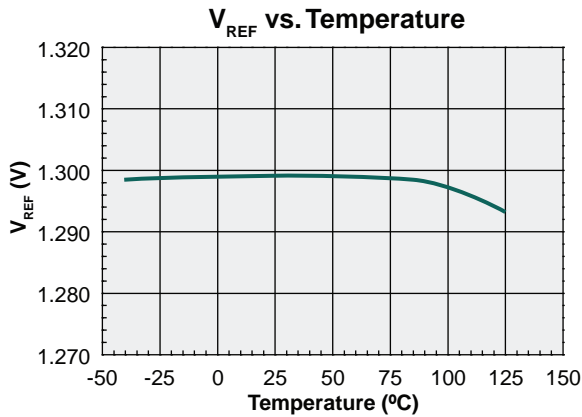

Figure 4: I_{CE} Test Circuit



1.6 Performance Data



2. Functional Description

IX9915 is the functional equivalent of a 4-terminal 431 type precision shunt regulator and a high voltage Darlington transistor in the same package.

The typical application for IX9915 is shown in **Figure 5**.

Figure 5 IX9915 Application Diagram

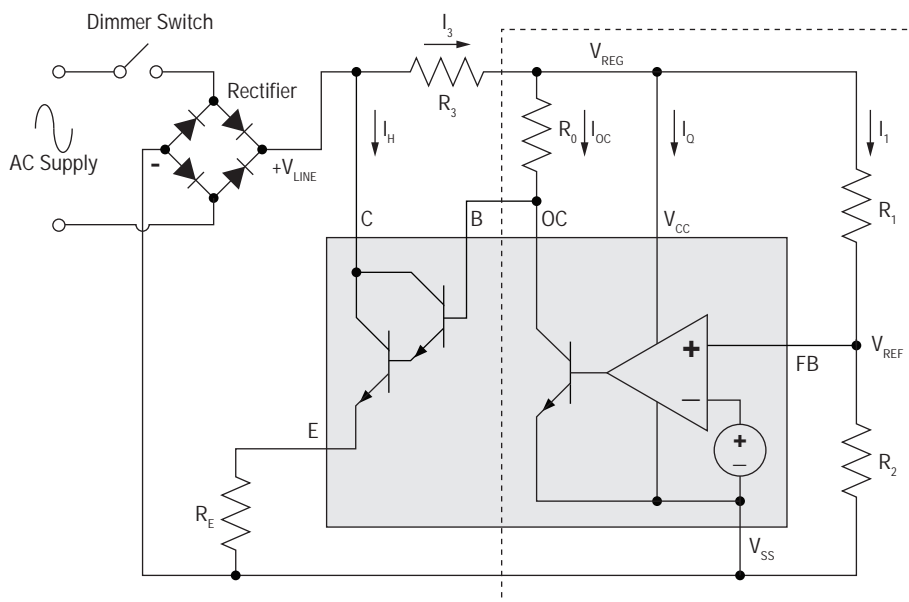

This is a simplified application circuit that shows how the IX9915 can be used in an LED lamp control circuit. The high voltage Darlington transistor will bleed the current when V_{LINE} is lower than the predetermined voltage. The 4-terminal 431 type shunt regulator is used to monitor V_{LINE} voltage and control the Darlington transistor bleeding the current (ON) or not (OFF). When V_{LINE} reaches the predetermined voltage, the shunt regulator starts to regulate to drive V_{OC} going low, and turns off the Darlington transistor to make sure this bleeder circuitry only burns a little power at the higher V_{LINE} voltage. Maximum bleeding current I_H can be controlled by properly choosing R_E and V_{REG}.

Regulation of V_{REG} is made possible by applying a scaled sample of its voltage to pin FB, the error amplifier's non-inverting input. The error amplifier compares this scaled voltage against an internal high accuracy reference voltage and generates an output current which in turn regulate V_{REG} through the resistor R₃.

As V_{REG} increases, the error amplifier's input voltage V_{FB} will also increase. Ramping of V_{FB} beyond the internal reference voltage causes the error amplifier to sink more I_{OC}, which in turn decreases V_{REG}. Likewise, a reduction of V_{REG} results in a lessening of I_{OC} causing V_{REG} to increase.

2.1 Regulation Voltage

When connected as shown in the application circuit above and properly configured, the IX9915 will regulate V_{REG} such that V_{FB} is equal to V_{REF}(1.299V). To achieve this, the values of the voltage divider resistors, R₁ and R₂, must be set in the following manner:

$$\frac{R_1}{R_2} = \frac{V_{REG}}{V_{REF}} - 1$$

Because V_{REG} regulation occurs when V_{FB}=V_{REF} any change in bias current through R₂ at the desired regulated voltage level will cause a regulation error. As shown in the Electrical Characteristics table the error amplifier input at pin FB has an input bias current (I_B) specification that reduces the current into R₂. (I_B is

always into pin FB). This error causes the regulated output voltage to increase which increases the current through R_1 by an amount equal to I_{IB} , thereby restoring the current through R_2 to its original value. Reducing the V_{REG} error created by the input bias current to less than 1% is accomplished by setting the value of R_1 using the following formula:

$$R_1 < \frac{V_{REG}}{50\mu A}$$

Where:

$$50\mu A = 100 \cdot I_{IB(MAX)}$$

2.2 Compensation

The dominate pole of the error amplifier is around 13kHz. In a typical system with a low-bandwidth requirement, it doesn't need any external compensation. Frequency response of the system can be optimized for the specific application by placing a compensation network between the OC and FB pins of the IX9915. For designs with more critical bandwidth requirements, measurement of the loop response must be made and compensation adjusted as necessary.

2.3 Design Example

A design example for the bleeder circuitry in LED lamp exhibits the detailed steps. In this example, it will target the predetermined voltage $V_{LINE-TH}=25V$ and maximum bleeding current $I_{H-MAX}=25mA$.

In order to flow the maximum bleeding current I_{H-MAX} through the Darlington transistor:

$$V_{REG} = I_{H-MAX} \cdot R_E + V_{BE} \quad (1)$$

If taking $R_E=100\Omega$:

$$\begin{aligned} V_{REG} &= I_{H-MAX} \cdot R_E + V_{BE} \\ &= 25mA \cdot 100\Omega + 1.5V \\ &= 4V \end{aligned}$$

In fact, the components in the dashed rectangle function as a comparator, its gain:

$$\begin{aligned} A &= \frac{R_0 \cdot R_2 \cdot g_m}{R_1 + R_2} \\ \frac{R_2}{R_1 + R_2} &= \frac{V_{REF}}{V_{REG}} = \frac{1.299V}{4V} = 0.325 \\ g_m &= 1S \text{ (typical)} \end{aligned}$$

If taking $R_0=40k\Omega$, the gain of the comparator is around 82dB. That is to say, once the error amplifier starts to regulate, the Darlington transistor will be shut off by this comparator. So, I_{OC} can be ignored for affecting the predetermined voltage:

$$V_{LINE-TH} \approx V_{REG} + (I_1 + I_Q) \cdot R_3 \quad (2)$$

Almost full power supply voltage will cross over R_3 , taking $R_3=100k\Omega$ to minimize its power consumption:

$$P = \frac{(V_{rms})^2}{100k\Omega}$$

Substituting:

- $I_Q=75\mu A$,
- $I_1=V_{REF} / R_2$,
- $V_{LINE-TH}=25V$

into formula (2):

$$\begin{aligned} R_2 &\approx 9.6k\Omega \\ R_1 &= R_2 \cdot \left(\frac{V_{REG}}{V_{REF}} - 1 \right) \\ R_1 &\approx 20k\Omega \end{aligned}$$

3. Manufacturing Information

3.1 Moisture Sensitivity



All plastic encapsulated semiconductor packages are susceptible to moisture ingress. IXYS Integrated Circuits Division classifies its plastic encapsulated devices for moisture sensitivity according to the latest version of the joint industry standard, **IPC/JEDEC J-STD-020**, in force at the time of product evaluation. We test all of our products to the maximum conditions set forth in the standard, and guarantee proper operation of our devices when handled according to the limitations and information in that standard as well as to any limitations set forth in the information or standards referenced below.

Failure to adhere to the warnings or limitations as established by the listed specifications could result in reduced product performance, reduction of operable life, and/or reduction of overall reliability.

This product carries a **Moisture Sensitivity Level (MSL)** classification as shown below, and should be handled according to the requirements of the latest version of the joint industry standard **IPC/JEDEC J-STD-033**.

Device	Moisture Sensitivity Level (MSL) Classification
IX9915N	MSL 1

3.2 ESD Sensitivity



This product is **ESD Sensitive**, and should be handled according to the industry standard **JESD-625**.

3.3 Soldering Profile

Provided in the table below is the Classification Temperature (T_C) of this product and the maximum dwell time the body temperature of this device may be ($T_C - 5$)°C or greater. The classification temperature sets the Maximum Body Temperature allowed for this device during lead-free reflow processes. For through-hole devices, and any other processes, the guidelines of **J-STD-020** must be observed.

Device	Classification Temperature (T_C)	Dwell Time (t_p)	Max Reflow Cycles
IX9915N	260°C	30 seconds	3

3.4 Board Wash

IXYS Integrated Circuits Division recommends the use of no-clean flux formulations. Board washing to reduce or remove flux residue following the solder reflow process is acceptable provided proper precautions are taken to prevent damage to the device. These precautions include but are not limited to: using a low pressure wash and providing a follow up bake cycle sufficient to remove any moisture trapped within the device due to the washing process. Due to the variability of the wash parameters used to clean the board, determination of the bake temperature and duration necessary to remove the moisture trapped within the package is the responsibility of the user (assembler). Cleaning or drying methods that employ ultrasonic energy may damage the device and should not be used. Additionally, the device must not be exposed to flux or solvents that are Chlorine- or Fluorine-based.

