

XPT IGBT phaseleg

ISOPLUS™

Surface Mount Power Device

$$I_{C25} = 43 \text{ A}$$

$$V_{CES} = 1200 \text{ V}$$

$$V_{CE(sat) \text{ typ}} = 1.9 \text{ V}$$

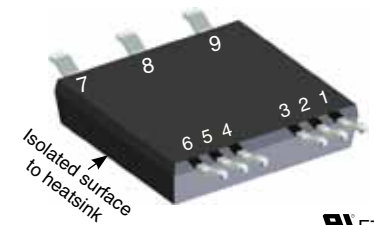

E72873

IGBTs S1, S2

Symbol	Conditions	Maximum Ratings
V_{CES}	$T_{VJ} = 25^{\circ}\text{C to } 150^{\circ}\text{C}$	1200 V
V_{GES}		± 20 V
I_{C25}	$T_C = 25^{\circ}\text{C}$	43 A
I_{C80}	$T_C = 80^{\circ}\text{C}$	30 A
I_{CM} V_{CEK}	$V_{GE} = 15 \text{ V}; R_G = 39 \Omega; T_{VJ} = 125^{\circ}\text{C}$ RBSOA, clamped inductive load; $L = 100 \mu\text{H}$	75 A V_{CES}
t_{SC} (SCSOA)	$V_{CE} = 900 \text{ V}; V_{GE} = \pm 15 \text{ V}; R_G = 39 \Omega; T_{VJ} = 125^{\circ}\text{C}$ none repetitive	10 μs
P_{tot}	$T_C = 25^{\circ}\text{C}$	150 W

Symbol	Conditions	Characteristic Values				
($T_{VJ} = 25^{\circ}\text{C}$, unless otherwise specified)						
		min.	typ.	max.		
$V_{CE(sat)}$	$I_C = 25 \text{ A}; V_{GE} = 15 \text{ V}; T_{VJ} = 25^{\circ}\text{C}$ $T_{VJ} = 125^{\circ}\text{C}$		1.9 2.2	2.2	V V	
$V_{GE(th)}$	$I_C = 1 \text{ mA}; V_{GE} = V_{CE}$	5.4		6.5	V	
I_{CES}	$V_{CE} = V_{CES}; V_{GE} = 0 \text{ V}; T_{VJ} = 25^{\circ}\text{C}$ $T_{VJ} = 125^{\circ}\text{C}$		200	2.1	mA μA	
I_{GES}	$V_{CE} = 0 \text{ V}; V_{GE} = \pm 20 \text{ V}$			500	nA	
$t_{d(on)}$ t_r $t_{d(off)}$ t_f E_{on} E_{off} $E_{(rec)off}$	Inductive load; $T_{VJ} = 125^{\circ}\text{C}$ $V_{CE} = 600 \text{ V}; I_C = 25 \text{ A}$ $V_{GE} = \pm 15 \text{ V}; R_G = 39 \Omega$		70 40 250 100 2.5 3.0 tbd		ns ns ns ns mJ mJ	
C_{ies}		$V_{CE} = 25 \text{ V}; V_{GE} = 0 \text{ V}; f = 1 \text{ MHz}$		tbd		pF
Q_{Gon}		$V_{CE} = 600 \text{ V}; V_{GE} = 15 \text{ V}; I_C = 25 \text{ A}$		76		nC
R_{thJC}					0.85	K/W
R_{thJH}		with heatsink compound (IXYS test setup)		0.95	1.3	K/W

Features

- **XPT IGBT**
 - low saturation voltage
 - positive temperature coefficient for easy paralleling
 - fast switching
 - short tail current for optimized performance in resonant circuits
- **Sonic™ diode**
 - fast reverse recovery
 - low operating forward voltage
 - low leakage current
- **$V_{CE(sat)}$ detection diode**
 - integrated into package
 - very fast diode
- **Package**
 - isolated back surface
 - low coupling capacity between pins and heatsink
 - PCB space saving
 - enlarged creepage towards heatsink
 - application friendly pinout
 - low inductive current path
 - high reliability

Applications

- **Phaseleg**
 - buck-boost chopper
- **Full bridge**
 - power supplies
 - induction heating
 - four quadrant DC drives
 - controlled rectifier
- **Three phase bridge**
 - AC drives
 - controlled rectifier

Diodes D1, D2

Symbol	Conditions	Maximum Ratings			
I_{F25}	$T_C = 25^\circ\text{C}$	40	A		
I_{F80}	$T_C = 80^\circ\text{C}$	27	A		

Symbol	Conditions	Characteristic Values			
($T_{VJ} = 25^\circ\text{C}$, unless otherwise specified)					
		min.	typ.	max.	
V_F	$I_F = 20\text{ A}$		1.9	2.4	V
			1.9		V
I_{RM}	$I_F = 20\text{ A}; R_G = 39\ \Omega; T_{VJ} = 125^\circ\text{C}$ $V_R = 600\text{ V}; V_{GE} = -15\text{ V}$		30		A
t_{rr}			350		ns
E_{rec}			0.85		mJ
R_{thJC}	per diode			0.9	K/W
R_{thJH}	with heatsink compound (IXYS test setup)		1.2	1.5	K/W

Diodes D3, D4

Symbol	Conditions	Maximum Ratings			
V_R	$T_C = 25^\circ\text{C}$ to 150°C	1200	V		

Symbol	Conditions	Characteristic Values			
($T_{VJ} = 25^\circ\text{C}$, unless otherwise specified)					
		min.	typ.	max.	
V_F	$I_F = 1\text{ A}$		1.7	2.2	V
			1.5		V
I_R	$V_R = 1200\text{ V}$			2	μA
			30		μA
I_{RM}	$I_F = 1\text{ A}; di_F/dt = -100\text{ A}/\mu\text{s}; T_{VJ} = 25^\circ\text{C}$ $V_R = 100\text{ V}; V_{GE} = 0\text{ V}$		2.3		A
t_{rr}			40		ns

Component

Symbol	Conditions	Maximum Ratings			
T_{VJ}		-55...+150	$^\circ\text{C}$		
T_{stg}		-55...+125	$^\circ\text{C}$		
V_{ISOL}	$I_{ISOL} \leq 1\text{ mA}; 50/60\text{ Hz}$	2500	V~		
F_C	mounting force	40 ... 130	N		

Symbol	Conditions	Characteristic Values			
		min.	typ.	max.	
C_P	coupling capacity between shorted pins and backside metal		90		pF
d_S, d_A	pin - pin	1.65			mm
d_S, d_A	pin - backside metal	4			mm
CTI		400			
Weight			8		g

Ordering	Ordering Name	Marking on Product	Delivering Mode	Base Qty	Ordering Code
Standard	IXA30PG1200DHGLB-TRR	IXA30PG1200DHGLB	Tape&Reel	200	511846

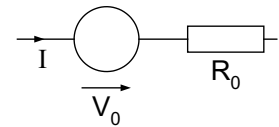
Equivalent Circuits for Simulation
Conduction

 IGBTs (typ. at $V_{GE} = 15\text{ V}; T_J = 125^\circ\text{C}$)
 S1, S2 $V_0 = 1.1\text{ V}; R_0 = 60\text{ m}\Omega$

 Diodes (typ. at $T_J = 125^\circ\text{C}$)
 D1, D2 $V_0 = 1.3\text{ V}; R_0 = 28\text{ m}\Omega$

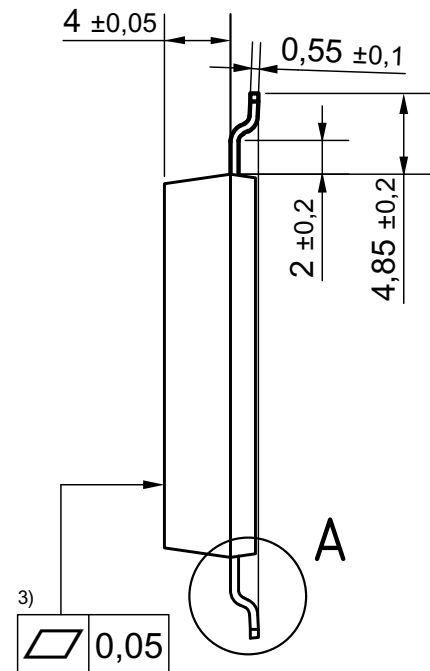
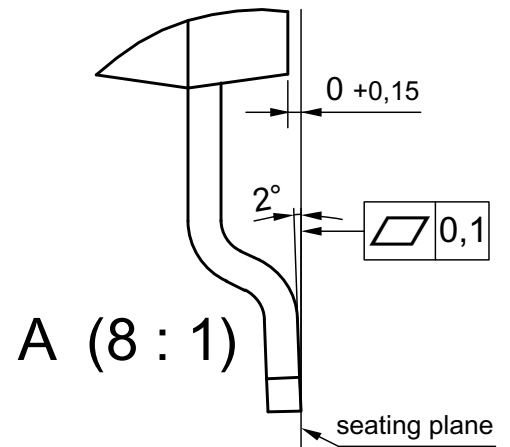
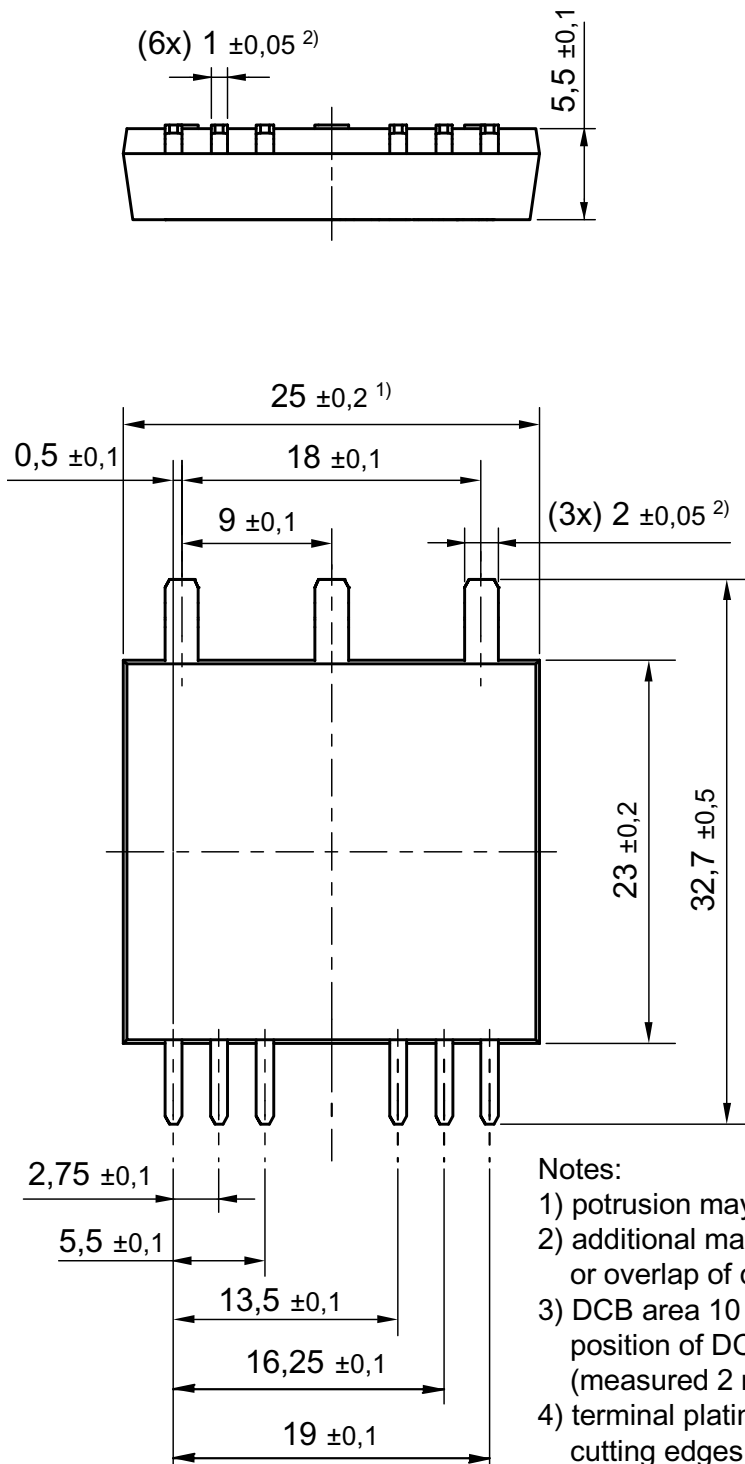
Dimensions in mm (1 mm = 0.0394")

Notes:

- 1) potrusion may add 0.2 mm max. on each side
- 2) additional max. 0.05 mm per side by punching misalignment or overlap of dam bar or bending compression
- 3) DCB area 10 to 50 μm convex;
position of DCB area in relation to plastic rim: $\pm 25 \mu\text{m}$ (measured 2 mm from Cu rim)
- 4) terminal plating: 0.2 - 1 μm Ni + 10 - 25 μm Sn (gal v.)
cutting edges may be partially free of plating

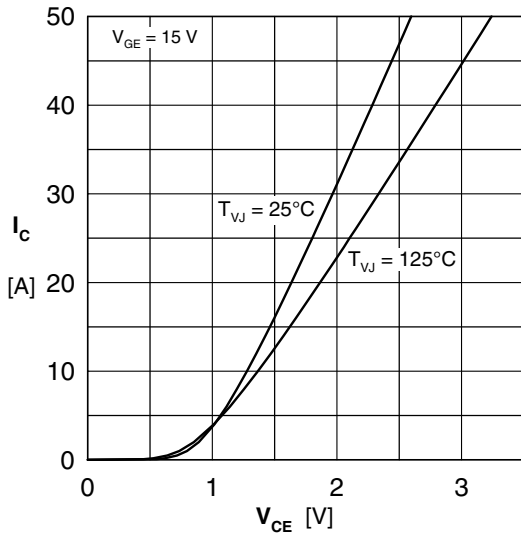

Fig. 1 Typ. output characteristics

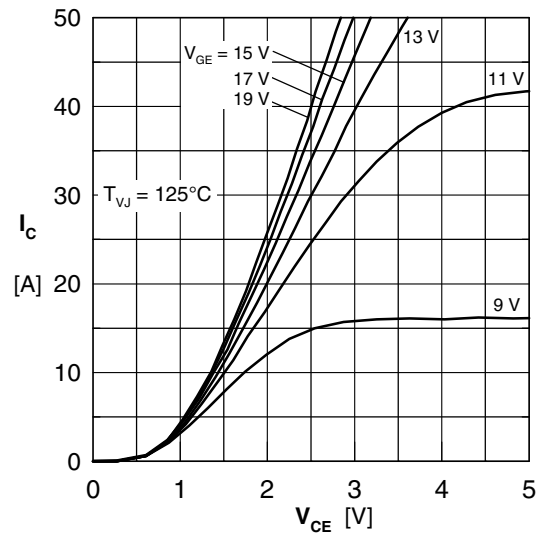

Fig. 2 Typ. output characteristics

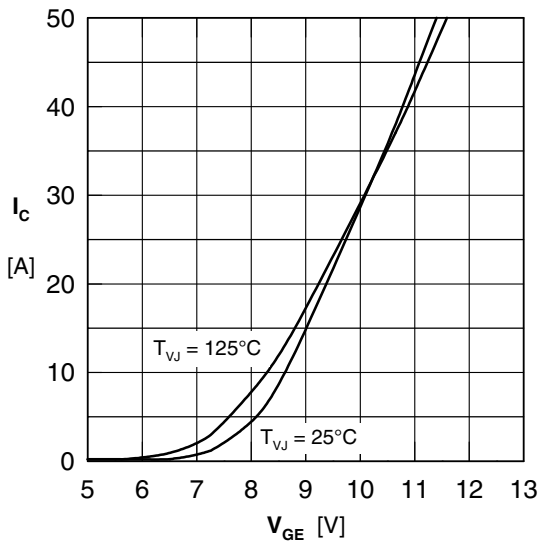

Fig. 3 Typ. transfer characteristics

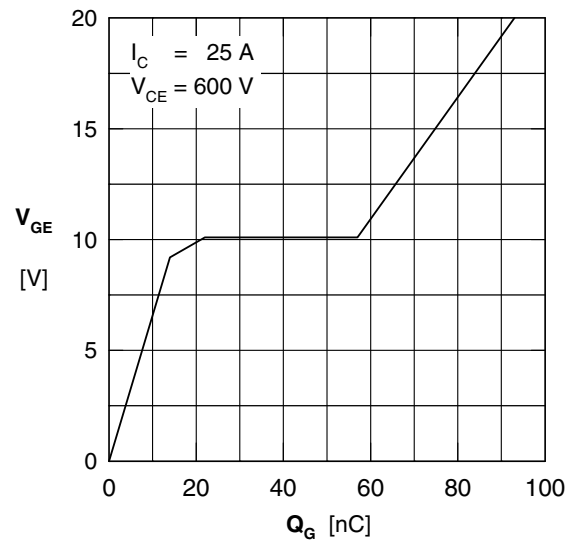

Fig. 4 Typ. turn-on gate charge

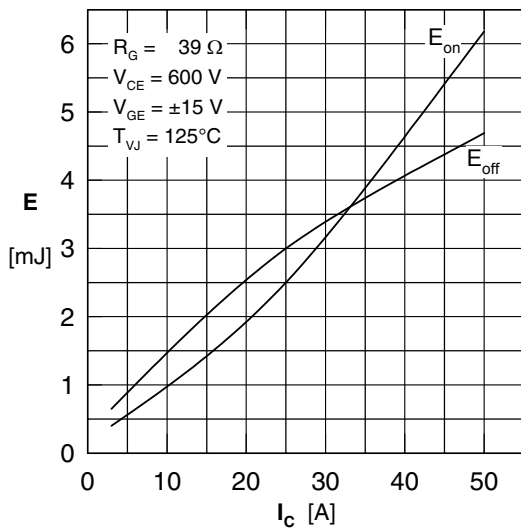

Fig. 5 Typ. switching energy vs. collector current

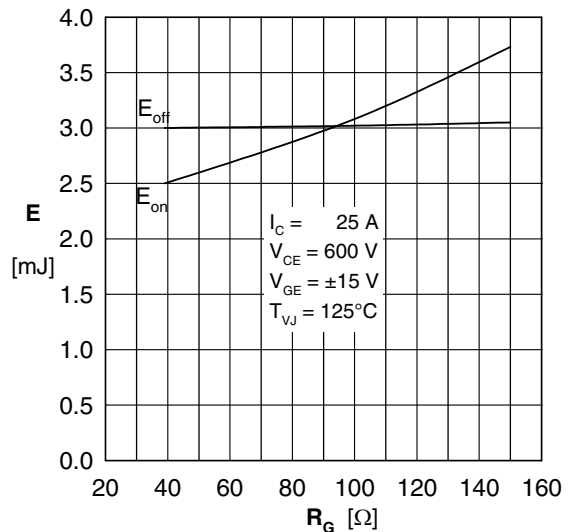

Fig. 6 Typ. switching energy vs. gate resistance

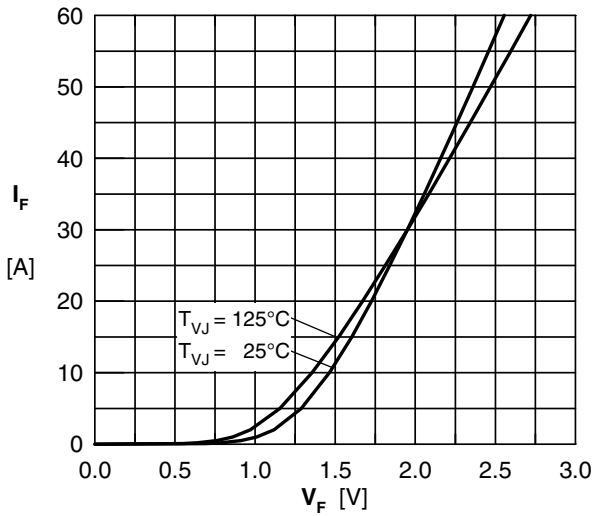

Fig. 7 Typ. Forward current versus V_F

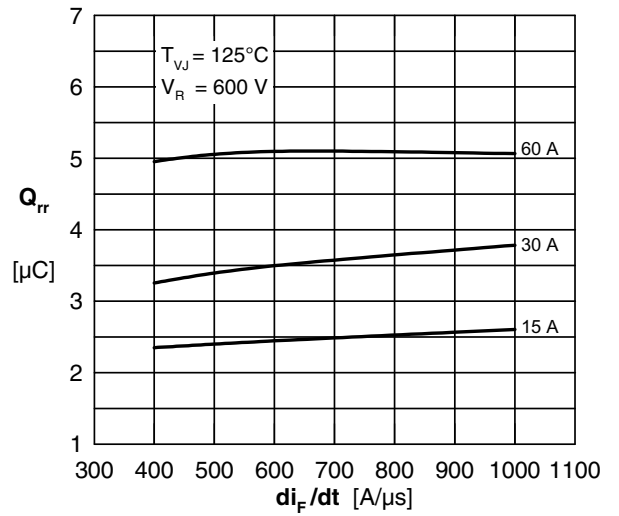

Fig. 8 Typ. reverse recov.charge Q_{rr} vs. di/dt

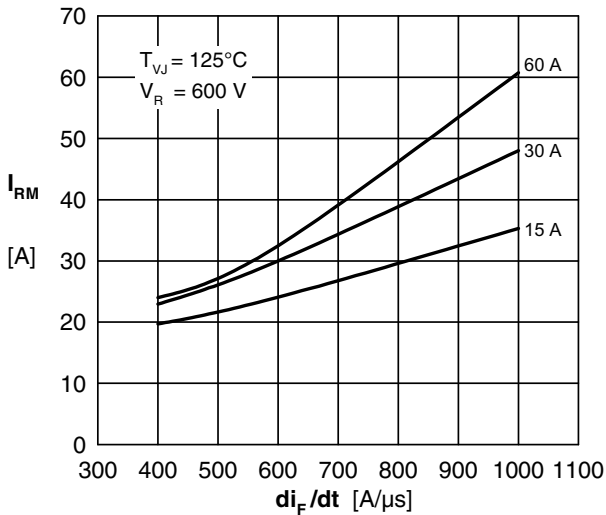

Fig. 9 Typ. peak reverse current I_{RM} vs. di/dt

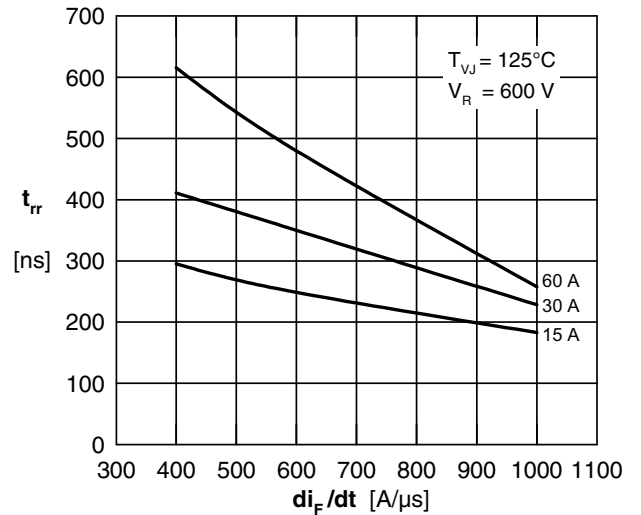

Fig.10 Typ. recovery time t_{rr} versus di/dt

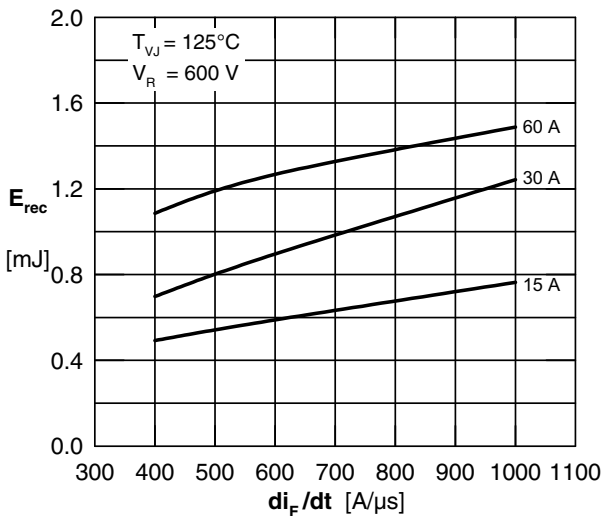

Fig.11 Typ. recovery energy E_{rec} versus di/dt