

HiPerFET™ Power MOSFET

Single MOSFET Die

Preliminary data sheet

IXFE 36N100
IXFE 34N100

| V_{DSS} | I_{D25} | $R_{DS(on)}$ |
|---------------|-------------|---------------------------------|
| 1000 V | 33 A | 0.24 Ω |
| 1000 V | 30 A | 0.28 Ω |

$t_{rr} \leq 250$ ns

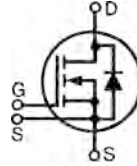

Symbol Test Conditions

Maximum Ratings

| | | | |
|---------------|--|--------------------------------------|------------------|
| V_{DSS} | $T_J = 25^\circ\text{C}$ to 150°C | 1000 | V |
| V_{DGR} | $T_J = 25^\circ\text{C}$ to 150°C , $R_{GS} = 1\text{M}\Omega$ | 1000 | V |
| V_{GS} | Continuous | ± 20 | V |
| V_{GSM} | Transient | ± 30 | V |
| I_{D25} | $T_C = 25^\circ\text{C}$ | 36N100: 33 34N100: 30 | A |
| I_{DM} | $T_C = 25^\circ\text{C}$; Note 1 | 36N100: 144 34N100: 136 | A |
| I_{AR} | $T_C = 25^\circ\text{C}$ | 36 | A |
| E_{AR} | $T_C = 25^\circ\text{C}$ | 64 | mJ |
| E_{AS} | $T_C = 25^\circ\text{C}$ | 4 | J |
| dv/dt | $I_S \leq I_{DM}$, $di/dt \leq 100$ A/ μs , $V_{DD} \leq V_{DSS}$ $T_J \leq 150^\circ\text{C}$, $R_G = 2 \Omega$ | 5 | V/ns |
| P_D | $T_C = 25^\circ\text{C}$ | 580 | W |
| T_J | | -55 ... +150 | $^\circ\text{C}$ |
| T_{JM} | | 150 | $^\circ\text{C}$ |
| T_{stg} | | -55 ... +150 | $^\circ\text{C}$ |
| T_L | 1.6 mm (0.063 in) from case for 10 s | 300 | $^\circ\text{C}$ |
| V_{ISOL} | 50/60 Hz, RMS $t = 1$ min $I_{ISOL} \leq 1$ mA $t = 1$ s | 2500 3000 | V~ V~ |
| M_d | Mounting torque Terminal connection torque | 1.5/13 Nm/lb.in. 1.5/13 Nm/lb.in. | |
| Weight | | 19 | g |

ISOPLUS 227™ (IXFE)



G = Gate
S = Source
D = Drain

Either Source terminal at miniBLOC can be used as Main or Kelvin Source

Features

- Conforms to SOT-227B outline
- Low $R_{DS(on)}$ HDMOS™ process
- Rugged polysilicon gate cell structure
- Unclamped Inductive Switching (UIS) rated
- Low package inductance
- Fast intrinsic Rectifier

Applications

- DC-DC converters
- Battery chargers
- Switched-mode and resonant-mode power supplies
- DC choppers
- Temperature and lighting controls

Advantages

- Low cost
- Easy to mount
- Space savings
- High power density

Symbol Test Conditions ($T_J = 25^\circ\text{C}$, unless otherwise specified)

Characteristic Values

| | | Min. | Typ. | Max. |
|--------------|--|---|------|--------------------------------|
| V_{DSS} | $V_{GS} = 0$ V, $I_D = 3$ mA | 1000 | | V |
| $V_{GS(th)}$ | $V_{DS} = V_{GS}$, $I_D = 8$ mA | 3.0 | | 5.0 V |
| I_{GSS} | $V_{GS} = \pm 20$ V, $V_{DS} = 0$ V | | | ± 200 nA |
| I_{DSS} | $V_{DS} = V_{DSS}$ $V_{GS} = 0$ V | $T_J = 25^\circ\text{C}$ $T_J = 125^\circ\text{C}$ | | 100 μA 2 mA |
| $R_{DS(on)}$ | $V_{GS} = 10$ V, $I_D = I_T$ Note 2 | 36N100 34N100 | | 0.24 Ω 0.28 Ω |

| Symbol | Test Conditions | Characteristic Values | | |
|---|--|-----------------------|------|------|
| | | Min. | Typ. | Max. |
| g_{fs} | $V_{DS} = 10\text{ V}; I_D = I_T$, Note 2 | 18 | 28 | S |
| C_{iss} | $V_{GS} = 0\text{ V}, V_{DS} = 25\text{ V}, f = 1\text{ MHz}$ | 15000 | | pF |
| C_{oss} | | 1400 | | pF |
| C_{rss} | | 340 | | pF |
| $t_{d(on)}$ t_r $t_{d(off)}$ t_f | $V_{GS} = 10\text{ V}, V_{DS} = 0.5 \cdot V_{DSS}, I_D = I_T$ $R_G = 1\ \Omega$ (External), | 81 | | ns |
| | | 82 | | ns |
| | | 150 | | ns |
| | | 40 | | ns |
| $Q_{g(on)}$ Q_{gs} Q_{gd} | $V_{GS} = 10\text{ V}, V_{DS} = 0.5 \cdot V_{DSS}, I_D = I_T$ | 455 | | nC |
| | | 120 | | nC |
| | | 185 | | nC |
| R_{thJC} R_{thCK} | | | 0.22 | K/W |
| | | | 0.07 | K/W |

Source-Drain Diode

($T_J = 25^\circ\text{C}$, unless otherwise specified)

| Symbol | Test Conditions | Characteristic Values | | | |
|----------------------|---|--|----------------|------------|---------------------------|
| | | Min. | Typ. | Max. | |
| I_S | $V_{GS} = 0$ | 36N100 34N100 | | 36 34 | A A |
| I_{SM} | Repetitive; pulse width limited by T_{JM} | 36N100 34N100 | | 144 136 | A A |
| V_{SD} | $I_F = I_S, V_{GS} = 0\text{ V}$, Pulse test, $t \leq 300\ \mu\text{s}$, duty cycle $d \leq 2\%$ | | | 1.3 | V |
| t_{rr} | $I_F = I_S, -di/dt = 100\text{ A}/\mu\text{s}, V_R = 100\text{ V}$ | $T_J = 25^\circ\text{C}$ $T_J = 25^\circ\text{C}$ $T_J = 25^\circ\text{C}$ | 180 30 2 | | ns ns μC |
| Q_{RM} I_{RM} | | | 8 | | A |

- Notes:
1. Pulse width limited by T_{JM} .
 2. Pulse test, $t \leq 300\text{ ms}$, duty cycle $d \leq 2\%$.
 3. I_T Test current:
IXFE36N100: $I_T = 18\text{ A}$
IXFE34N100: $I_T = 17\text{ A}$

ISOPLUS-227 B

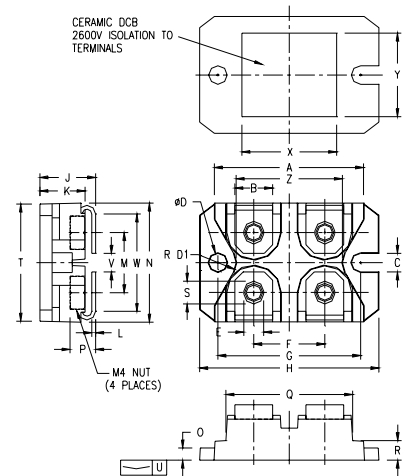

| SYM | INCHES | | MILLIMETERS | |
|-----|--------|-------|-------------|-------|
| | MIN | MAX | MIN | MAX |
| A | 1.240 | 1.270 | 31.50 | 32.26 |
| B | .310 | .330 | 7.87 | 8.38 |
| C | .155 | .165 | 3.94 | 4.19 |
| D | .155 | .165 | 3.94 | 4.19 |
| D1 | .150 | .157 | 3.81 | 3.98 |
| E | .160 | .168 | 4.06 | 4.27 |
| F | .587 | .595 | 14.91 | 15.11 |
| G | 1.186 | 1.193 | 30.12 | 30.30 |
| H | 1.489 | 1.505 | 37.80 | 38.23 |
| J | .465 | .481 | 11.81 | 12.22 |
| K | .370 | .380 | 9.40 | 9.65 |
| L | .030 | .033 | 0.76 | 0.84 |
| M | .496 | .506 | 12.60 | 12.85 |
| N | .990 | 1.001 | 25.15 | 25.42 |
| O | .100 | .105 | 2.54 | 2.67 |
| P | .195 | .235 | 4.95 | 5.97 |
| Q | 1.045 | 1.059 | 26.54 | 26.90 |
| R | .160 | .170 | 4.06 | 4.32 |
| S | .186 | .191 | 4.72 | 4.85 |
| T | .968 | .987 | 24.59 | 25.07 |
| U | -.001 | .002 | -0.03 | 0.05 |
| V | .130 | .160 | 3.30 | 4.06 |
| W | .780 | .830 | 19.81 | 21.08 |
| X | .770 | .810 | 19.56 | 20.57 |
| Y | .680 | .720 | 17.27 | 18.29 |
| Z | .885 | .892 | 22.48 | 22.66 |

Please see IXFN36N100 data sheet for characteristic curves.