

ORDERING GUIDE

# Slimline Power System

48V DC Outside Plant and Customer Premise Solution



---

# Table of contents

03	Overview
04 - 06	Rectifier Specifications
07 - 09	Controller Specifications
10	SPS System Overview
11	1RU Shelf Solutions
12	2RU Custom Shelf
13 - 14	Stackable Solutions
15 - 16	DIN Rail Solutions
17 - 21	System Components

# Slimline Power System

## 48V DC Outside Plant and Customer Premise Solution

The Slimline Power System provides advanced controller features in a compact, cost-efficient footprint. The SPS platform is based around a 1RU shelf configuration with an array of combinations of rectifier shelves and distribution options to address 500W to 19200W applications. The Pulsar Edge controller has Ethernet connectivity to facilitate remote network management to monitor and control rectifiers, batteries, and distribution. The SPS is a full featured and reliable DC power solution where system height and depth are restricted, but large system performance is critical to success.

### Shelf Options

The Slimline Power System product line provides several shelf options equipped with Ethernet, alarm inputs/outputs, and 1-Wire™ connection for battery voltage and temperature monitoring. The SPS system can be deployed using 1RU rectifier shelves that can be mated with 1RU distribution panels, offering flexibility to grow the system to meet power level and distribution requirements up to 19200 Watts. The SPS platform can also be deployed with 3RU DIN rail distribution panel which delivers universal flexibility for applications around the world.

### SPS TE Rectifier

This hardened rectifier is a single phase, hot pluggable, fan cooled rectifier that provides up to 1600 Watts of high availability DC power. The constant output power characteristics, extended temperature range, universal AC input, and compact size are key attributes that make this rectifier the right choice for your power needs.

### Pulsar Edge Controller

SPS features the Pulsar Edge controller delivering large system intelligence in a small system form factor. Ethernet connectivity with SNMP facilitates remote network management.

### Features and Benefits

#### Reliability

- Simplified deployment
- Proven field performance
- Hardened for extreme environments

#### Intelligence

- Industry leading controller features
- Ethernet interface for remote access
- Centralized network management

#### Investment Protection

- Engineered to reduce installation time
- Versatile configurations
- Efficient operation

#### On Time Delivery

- Standard building blocks
- 4 - 6 week availability
- 24/7 technical support

- Customer premise power for converged networks
- Large plant features in a small plant package
- 4800 Watt/90 Amps single shelf capacity in 1RU
- Expandable to 19200 Watts/ 360 Amps in 4800 Watt/90 Amp 1RU increments
- 10.3 inches (264mm) depth is ideal where space is restricted.
- Over 95% Efficiency
- Flexible distribution options in 1RU increments

## SPS TE Rectifiers

The SPS TE rectifiers are single phase, hot-pluggable, fan cooled rectifiers that provide highly reliable DC power. As cost-effective rectifiers that occupy just 1RU, its shallow depth is an ideal power solution for space critical applications. The constant output power characteristics as well as the extended temperature range, universal AC input voltage range and compact size are key attributes that make this rectifier the right choice for your power needs.

These rectifiers are applicable for indoor and outdoor environments especially where equipment depth and height are restricted. The SPS TE rectifiers communicate digitally to the Pulsar Edge controller family over a RS485 bus to add extensive monitoring and alarm management facilities. Its flexible and sophisticated feature set makes this front-end supply an excellent choice for power in a variety of application spaces.



### Applications

- Telecommunications networks
- Digital subscriber line (DSL)
- Indoor/outdoor wireless
- Routers/switches
- Fiber in the loop
- Transmission
- Data networks
- PBX

### Key Features

- Extended temperature range
- Redundant fan cooling
- Front panel LED indicators
- 1U height, minimized depth
- Universal AC input
- Analog load sharing
- Hot pluggable
- RoHS compliant

# Specifications

Input	EP0500UTEZ	EP1000UTEZ	EP1600UTEZ
<b>Voltage Range</b>			
Low-Line	90-175Vac (500W)	90-175Vac (1000W)	90-175Vac (1200W)
High-Line	176-264Vac (500W)	176-264Vac (1000W)	176-264Vac (1600W)
<b>Input Current</b>			
	6.25-4.5A @ 90-120Vac	12.5-9.3A @ 90-120Vac	15-12A @ 90-120Vac
	2.55A @ 230Vac	5.1A @ 230Vac	7.5A @ 230Vac
Input Frequency	45 – 65Hz	45 – 65Hz	45 – 65Hz
Inrush Transient	25 Apk	25 Apk	25 Apk
Power Factor	~1.0	~1.0	~1.0
Efficiency	95%	95%	95%
Total Harmonic Distortion	<5%	<5%	<5%
Holdup Time	>10 ms full power	>10 ms full power	>10 ms full power
<b>Output</b>			
Voltage Adjust Range	42-58Vdc	42-58Vdc	42-58Vdc
<b>Rated Output Current</b>			
Low Line	10Adc max	20Adc max	24Adc max
High Line	10Adc max	20Adc max	32Adc max
Psophometric Noise	<5 mV max	<5 mV max	<5 mV max
Ripple	<200 mVpkpk	<200 mVpkpk	<200 mVpkpk
Overvoltage Protection	59.5Vdc	59.5Vdc	59.5Vdc
<b>Control and Monitoring</b>			
Visual Status Indicators	Run, Alarm and Fault LEDs		
Serial Interface	Half duplex RS485 (GP Protocol)		
<b>Environmental</b>			
Operating Temperature	-40°C to +75°C (-40°F to 167°F)		
Storage Temperature	-40°C to +85°C (-40°F to 185°F)		
Power Derating	> +50°C 2% per degree Celsius		
Humidity	< 95% non-condensing		
Altitude	4000M max		
Audible Noise	< 55dBA		
<b>Mechanical</b>			
Length (inch/mm)	8.11 / 206.0		
Width (inch/mm)	4.98 / 126.5		
Height (inch/mm)	1.64 / 41.6		
Weight (lb/Kg)	3.08 / 1.4		
<b>Safety and Standards Compliance</b>			
NEBs	Evaluated by independent NRTL test lab to Telcordia GR63 & GR 1089, Issue 4		
Safety	CE mark to Low Voltage Directive 2006/95/EC and EMC Directive 2004/108/E UL 62368-1 Recognized, CSA C22.2 No. 62368-1-03 Certified VDE0805:2001 12 (EN 62368) Licensed		
RoHS	Compliant to RoHS Directive 2011/65/EU and amended Directive (EU) 2015/863		
EMC	CISPR32 (EN55032) Class B and FCC-CFR, Part 15, sub-part B Class B with shelf; GR1089 Class A		
ESD	EN61000-4-2, Level 4		

Note: Special cooling may be needed

# Specifications (continued)

## Outline Drawings

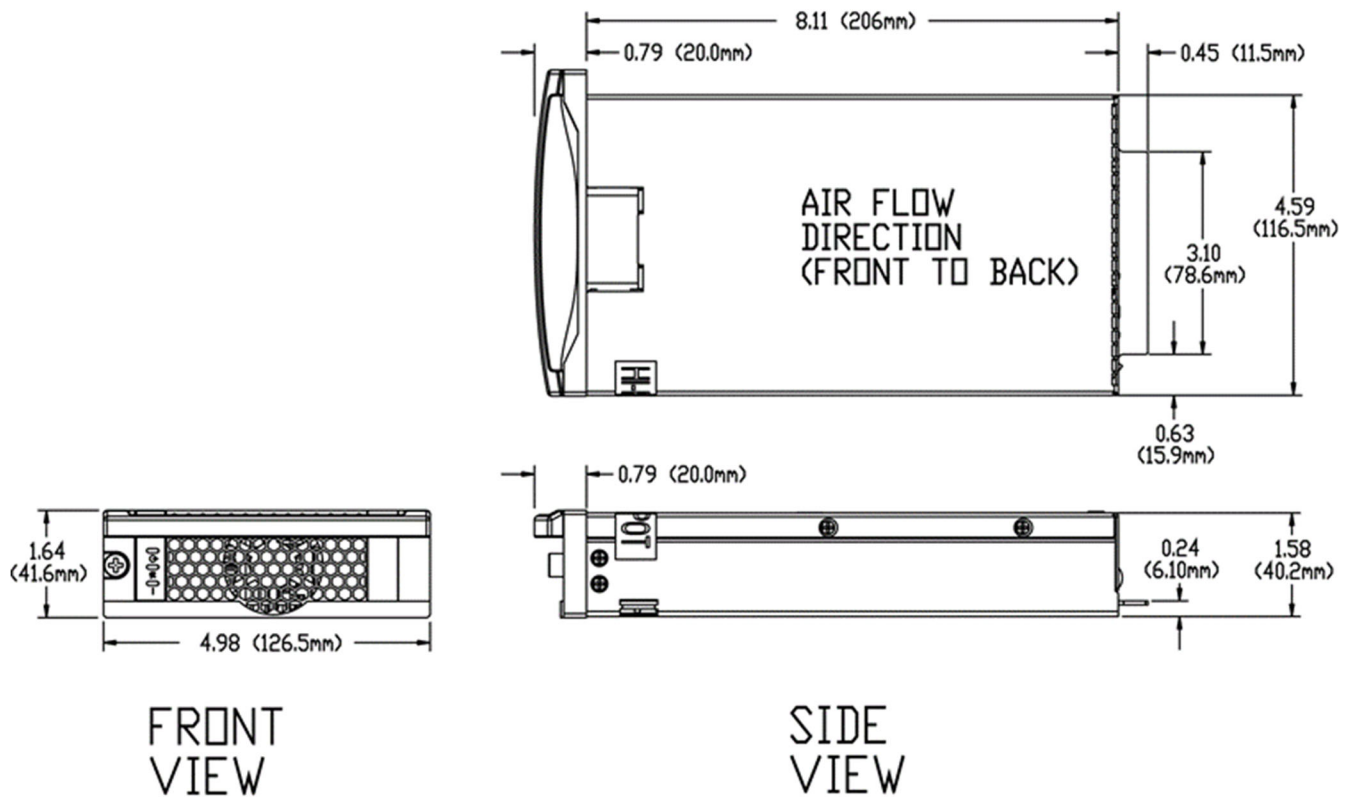

## Pulsar Edge Controller

The SPS Pulsar Edge controller delivers large system intelligence in a small system form factor. This family of controllers functions as network interface cards (NIC) and as a full-featured battery plant controller. Its thin modular plug-in form factor minimizes shelf space consumption allowing maximum power module and distribution capabilities.

The controller is utilized in bulk power applications in data centers and enterprise applications. Ethernet connectivity with SNMP facilitates remote network management. Access through its front-accessible RS232 or USB port and aided by the EasyView2 graphical enables full user interface locally. Optional 1U display version allows convenient access to all controller functions without requiring external cable connections. The display also features alarm context sensitive backlighting for at-a-glance system status.

As a battery plant controller, it provides a complete set of features to monitor and control rectifiers, batteries, and distribution. A flexible set of configurable inputs allow the Pulsar Edge controller to monitor a wide variety of system equipment and incorporate appropriate state information enabling a centralized point of management.

The controller utilizes standard network management protocols allowing for advanced network supervision. ABB Galaxy Manager\* software is the centralized visibility and control component of a comprehensive power management system designed to meet engineering, operations and maintenance needs. The Galaxy Manager client-server architecture enables remote access to system controllers across the power network.



## Applications

- Telecommunications networks
- Digital subscriber line (DSL)
- Indoor/outdoor wireless
- Routers/switches
- Fiber in the loop
- Transmission
- Data networks
- PBX

## Key Features

### Remote Access and Features

- Integrated 10/100Base-T Ethernet Network
  - TCP/IP
  - SNMP V2c for management
  - SMTP for email
  - Telnet for command line interface
  - DHCP for plug-n-play
  - FTP for rapid backup and upgrades
  - HTTP for standard web pages and browsers
  - Compatible with Galaxy Manager and other management packages
  - Shielded RJ-45 interface referenced to chassis ground
- Password protected security levels: User, Super-User, Administrator for all access
- Ground-referenced RS232 system port
- ANSI T1.317 command-line interface
- Modem access support
  - Remote via external modem
  - Call back security
- EasyView2, Windows-based GUI software for local terminal or Modem access
- Optional 1U display with alarm indicating backlight feature

### Standard System Features

- Monitor and control of more than 40 connected devices
  - Maximum of 32 rectifiers
  - Maximum of 6 distribution control cards
  - Robust RS485 system bus
- Standard and user defined alarms
  - Alarm test

- Assignable alarm severity: Critical, Major, Minor, Warning, and record-only
- Rectifier management features
  - Automatic rectifier restart
  - Adaptive Rectifier Management (energy efficiency)
  - Remote rectifier (on/off)
  - Reserve Operation
  - Automatic rectifier sequence control
  - N + X redundancy check
- Multiple Low Voltage Load and Low Voltage Battery Disconnect thresholds (4)
- Configuration, statistics, and history
  - All stored in non-volatile memory
  - Remote/local backup and restore of configuration data
- Industry standard defaults
  - Customer specific configurations available
- Remote/ local software upgrade
- Basic, busy hour, and trend statistics
- Detailed event history
- User defined events and derived channels

### Standard Battery Management Features

- Float/boost mode control
  - Manual boost
  - Manual timed boost locally, T1.317, and remotely initiated
  - Auto boost terminated by time or current
- Battery discharge testing
  - Manual (local/remote)
  - Periodic
  - Plant Battery Test (PBT) input driven
  - Configurable threshold or 20%



- algorithm
- Graphical discharge data
- Rectifiers on-line during test
- Slope thermal compensation
  - High temperature
  - Low temperature
  - Step temperature
  - STC Enable/Disable, low temperature Enable/Disable
  - Configurable mV/°C slopes
- State of charge indication
- High temperature disconnect setting
- Reserve-time prediction
- Recharge current limit
- Emergency Power-Off input
- Up to 15 binary inputs
  - Six inputs close/open to battery
  - 9 input close/open to return (number is dependent upon number of output alarms)
  - User assignable
- Up to 6 user assignable Form-C output alarms (50VDC @.3A)
- 1-Wire\* bus devices
  - Up to 16 temperature probes (QS873)
  - Up to 6 mid-string monitors (ES771)

### Galaxy Manager Compatible

- Centralized web server and database with multiple user access to live or managed data with drill down to problem details
- Monitor and control of more than 40 connected devices
- Management information from polling or alarms received from alarm traps from multiple sites are available on one screen via the inter/intranet
- Trend user selected data over time
- Automatic or manual report generation
- Standard engineering tools like reserve time calculators and cable voltage drop analyzer

### Integrated Monitoring Inputs/Outputs

- System plant voltage (accuracy  $\pm 0.5\%$ , resolution 0.01V)
- One system shunt (accuracy  $\pm 1\%$  full scale, resolution 1A)
  - Battery or load
  - Mounted in the return side of DC bus

### General

Operating Voltage	$\pm 24$ Vdc, $\pm 48$ Vdc (Range: $\pm 18$ to $\pm 60$ Vdc)
Input Power	Less than 7W
Operating Temperature Range	-40°C to +70°C (-40°F to 167°F)
Operating Relative Humidity	0 - 95% (non-condensing)
Storage Temperature Range	-40°C to +85°C (-40°F to 185°F)
Physical Specifications	1.75 in. H, 0.75 in. W, 8.00 in. D; 0.5lb
Display	8-line by 40-character backlit LCD
EMC	FCC/EN55032 Class A, CISPR32 Level A

### Agency Certifications

Electrostatic Discharge	EN 61000-4-2 level 4
Radiated Emissions	FCC, Class A; EN 55032, Class A
Safety	UL Listed Component as Part of CPL or SPS Power System

## Ordering Information – Slimline Power System

### 48V DC Outside Plant and Customer Premise Solution

The Slimline Power System power shelf provides advanced controller features in a compact, cost-efficient footprint. The SPS shelf is 1.75" high, 10.3" deep and mounts in 19-inch or 23-inch wide frames, with three power slots for rectifiers and distribution. The Pulsar Edge controller has Ethernet connectivity to facilitate remote network management to monitor and control rectifiers, batteries, and distribution. SPS is a reliable DC power solution where system height and depth are restricted.

#### Features

- SPS rectifiers produce 42Vdc to 58Vdc output; up to 1600W high line, 1200W low line
- Universal AC input: 90-290VAC
- AC input options: IEC-320 C13 or C19 style cords and universal rear AC screw terminal strip
- Temperature hardened harsh environments. (-40°C to +75°C)
- Compact 1U (1.75") 19" mount solutions (23" adapters available)
- Adjustable mounting ears for either flush front or 5-inch set back position
- Up to 4 rectifier shelves may be connected together for larger power requirements
- Plug-N-Play SPS841A controller with Web based interface available with or without display. All controllers available with craft port and remote LAN access.
- Integrated distribution options include one or two 30A battery breakers, up to 10 GMT load fuses and Low Voltage Battery Disconnect voltage and temperature monitoring.

- 1RU distribution panels available with battery and load breakers as well as pluggable fuse capabilities, battery shunt and Low Voltage Battery Disconnect (LVBD)
- 3RU DIN rail distribution panels available with battery and load breaker positions, battery shunt and Low Voltage Battery Disconnect (LVBD) and Low Voltage Load Disconnect (LVLVD)
- Stackable solutions shelves include bus and control straps to interconnect shelves

The SPS Product line provides Ethernet, alarm input/outputs and 1-Wire connection for battery voltage and temperature monitoring.

A variety of system configurations are available including:

- 1RU single shelf solutions with two rectifier slots and integrated distribution
- Stackable Solutions
- Custom Solutions

Up to four rectifier shelves may be stacked with 1RU GMT/Breaker distribution panels or 3RU DIN rail distributions. Interconnection hardware is included to quickly configure and assemble systems in the field or



1RU Solutions

Custom Solutions



Stackable Solutions

## 1RU Solutions

- 30A battery breaker with terminal block input for 8 gauge wire, LVBD option
- GMT fuses with terminal block output for 12 gauge wire, 15A max fuse size
- IEC plug, AC input
- 1-Wire port for battery voltage and temperature monitoring, LAN port, alarm cable connections



## 1RU Shelves

Ordering Code	Description (Image Key)	Rectifier Slots	DC Output	Battery Breakers	LVD	AC Input	
CC109148136	J2007003L001 (A)	3	Bulk (cabled)	Rear	0	None	Single IEC C19
CC109146503	J2007003L001A (A)	3	Bulk (cabled)	Rear	0	None	Individual IEC C13
CC109156114	J200700L011 (A)	3	12 GMT's	Rear	0	None	Single IEC C19
CC109148144	J2007003L002 (B)	2	6 GMT's	Front	1 - 30A	LVBD	Single IEC C13
CC109151536	J2007003L002A (B)	2	6 GMT's	Front	1 - 30A	LVBD	Individual IEC C13
CC109156907	J2007003L002X (B)	2	6 GMT's	Front	1 - 30A	None	Single IEC C13
CC109156915	J2007003L002AX (B)	2	6 GMT's	Front	1 - 30A	None	Individual IEC C13
CC109158696	J2007003L002AXB (B)	2	6 GMT's	Front	0	None	Individual IEC C13
CC109165890	J2007003L002D (C)	2	6 GMT's / Door	Front	1 - 30A	LVBD	Single IEC C13
CC109165916	J2007003L002AD (C)	2	6 GMT's / Door	Front	1 - 30A	LVBD	Individual IEC C13
CC109165908	J2007003L002XD (C)	2	6 GMT's / Door	Front	1 - 30A	None	Single IEC C13
CC109165924	J2007003L002AXD (C)	2	6 GMT's / Door	Front	1 - 30A	None	Individual IEC C13
CC109165932	J2007003L002AXB (C)	2	6 GMT's / Door	Front	0	None	Individual IEC C13
CC109146511	J2007003L004 (D)	2	10 GMT's	Rear	1 - 30A	LVBD	Single IEC C13
CC109156923	J2007003L004X (D)	2	10 GMT's	Rear	1 - 30A	None	Single IEC C13
150026024	J2007003L004XB (D)	2	10 GMT's	Rear	0	None	Single IEC C13
CC109151544	J2007003L004A (D)	2	10 GMT's	Rear	1 - 30A	LVBD	Individual IEC C13
CC109156931	J2007003L004AX (D)	2	10 GMT's	Rear	1 - 30A	None	Individual IEC C13
150024564	J2007003L004AXB (D)	2	10 GMT's	Rear	0	None	Individual IEC C13
CC109159372	J2007003L014 (D)	2	1-30A Brkr / 10GMT's	Rear	1 - 30A	LVBD	Rear Terminal
150033629	J2007003L014LA (D)	2	1-30A Brkr / 10GMT's	Rear	1 - 30A	LVLVD	Single IEC C13
150030787	J2007003L014XA (D)	2	1-30A Brkr / 10GMT's	Rear	1 - 30A	None	Single IEC C13

Ordering Code	AC Input , DC Output Cables (105C Wire)
CC848776105	C13 plug with 5-15P plug, 14AWG, 10'
CC848820317	C13 plug with L6-20P plug, 14AWG, 10'
847861192	C13 plug, unterminated, 14AWG, 10'
CC848885698	C13 AC Cord Retaining Clamp
CC848850792	C19 plug, with 5-15P plug, 12AWG, 8'
CC848850842	C19 plug, with L6-20P plug, 12AWG, 8'
CC848847368	C19 plug, unterminated, 12AWG, 8'
CC848887158	C19 AC Cord Retaining Clamp
848748987	DC output cable 2 AWG, 10' (List 1, 1A only)

Ordering Code	Alarm and Communication Cables
CC848890153	5' Alarm output cable (J1)
CC848865980	15' Alarm output cable (J1)
CC848817651	50' Alarm output cable (J1)
CC848890203	5' Alarm input cable (J2)
CC848853614	15' Alarm input cable (J2)
CC848890211	50' Alarm input cable (J2)
CC848847780	Shelf to shelf communication cable (J4) (List 1, 1A only)



Image Key (A)



Image Key (C)



Image Key (B)



Image Key (D)

# Custom Solutions

## 12 inch Wide - 2U Power Shelf

- Full front access for all connections
- 30A battery breaker with terminal block input for 8 gauge wire, LVBD option
- 6 GMT fuses with terminal block output for 12 gauge wire, 15A max fuse size
- 14 AWG AC cord with 5-15P plug
- 1-Wire port for battery voltage and temperature monitoring, LAN port, screw terminal alarm connections



### 12 inch Wide- 2U Power Shelf

Ordering Code	Description	Rectifier Slots	Height (Rack Units)	Load Positions	Battery Breaker Positions	LVD
150027893	J2007003L202	2	2 RU	6 GMT	1 (30A)	LVBD
150033772	J2007003L202X	2	2 RU	6 GMT	1 (30A)	No

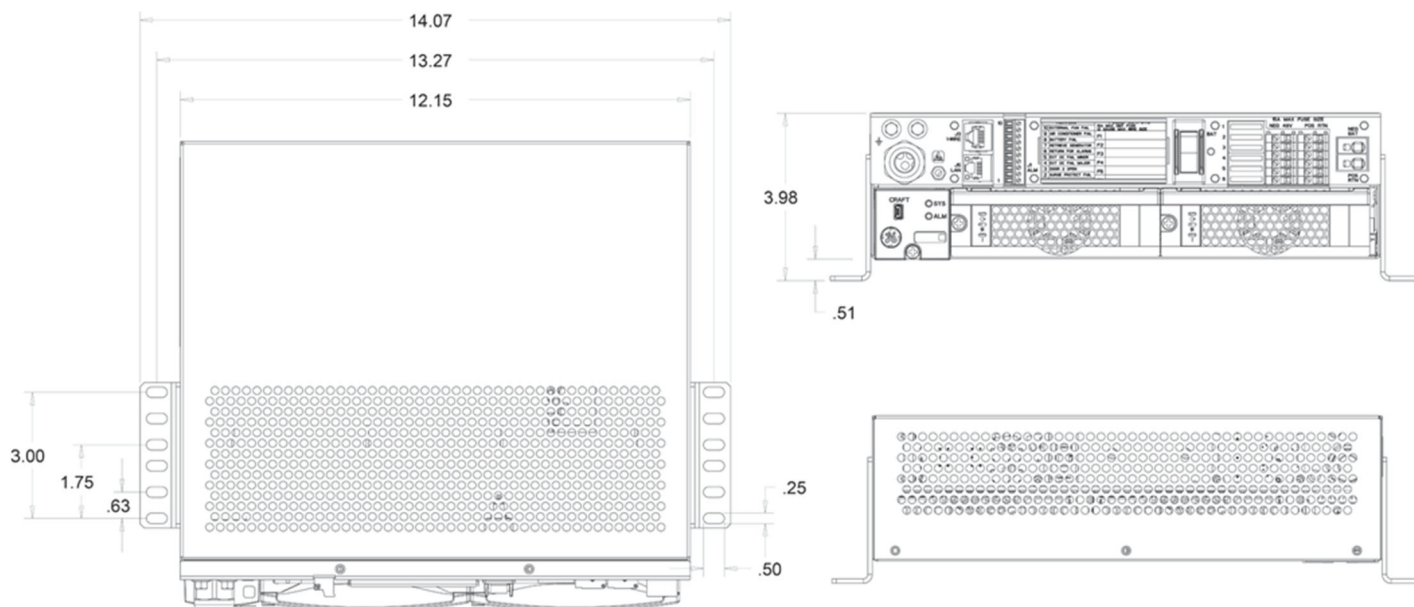

## Stackable Solutions

- Order configured systems from the factory or assemble shelves in the field
- Bullet-style battery and load breakers, up to 100A with 1/4-20 x 5/8 lug landings
- GMT fuses with terminal block output for 12 gauge wire, 15A max fuse size
- 12 AWG AC screw terminal block
- 1-Wire port for battery voltage and temperature monitoring, LAN port, screw terminal alarm connections



## Factory Configured Systems

Ordering Code	Description	Rectifier Slots	Load Breaker Positions	Battery Breaker Positions	LVD
150032348	SPS-2U-AC5-PS3-PS3-DC12B	2	12	2	No
150030465	SPS-2U-AC5-PS3-DC12B-LVBD	2	12	2	LVBD
150032349	SPS-2U-AC5-PS3-DC24B	0	24	2	No
150032350	SPS-2U-AC5-PS3-DC24B-LVBD	0	24	2	LVBD

## 1RU Distributions

Below is a list of individual distribution panels that can be used independently for localized distribution, be paired with an SPS rectifier shelf, or can be used to supplement existing solutions in the field.

Ordering Code	Model	Load Breaker Positions	GMT Fuse Positions	Battery Breaker Positions	Low Voltage Disconnect
150032396	J2013001L101	2	0	2	No
150032397	J2013001L101B	2	0	2	LVBD
150032343	J2013001L102	2	12	2	No
150032344	J2013001L102B	2	12	2	LVBD
150032345	J2013001L103	0	24	2	No
150032346	J2013001L103B	0	24	2	LVBD
150032398	J2013001L104	2	24	0	No
150032399	J2013001L105	4	12	0	No
150032400	J2013001L106	4	0	0	No
150032401	J2013001L107	0	36	0	No

## Rectifier Shelves

The following codes are for adding additional rectifier shelves to Infinity S plants in the field. Each kit includes: Rectifier shelf with mounting hardware, busbar interconnects with hardware and inter-shelf communication cable.

Note: Adding these shelves does not increase the overall rating of the distribution.

### 1RU Rectifier Shelves

Ordering Code	Description	AC Input	Rectifier Slots	Controller Support	DC Output
150028853	J2007003L051C	Rear AC Terminal	3	Yes	Rear Bulk
150028854	J2007003L052C	Rear AC Terminal	3	No	Rear Bulk

# Stackable Solutions - Drawings

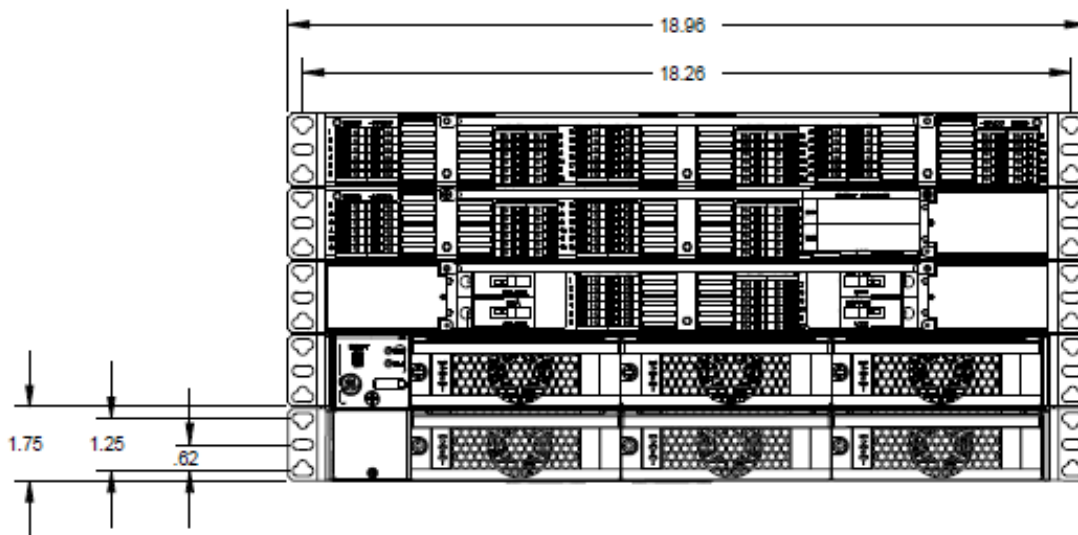
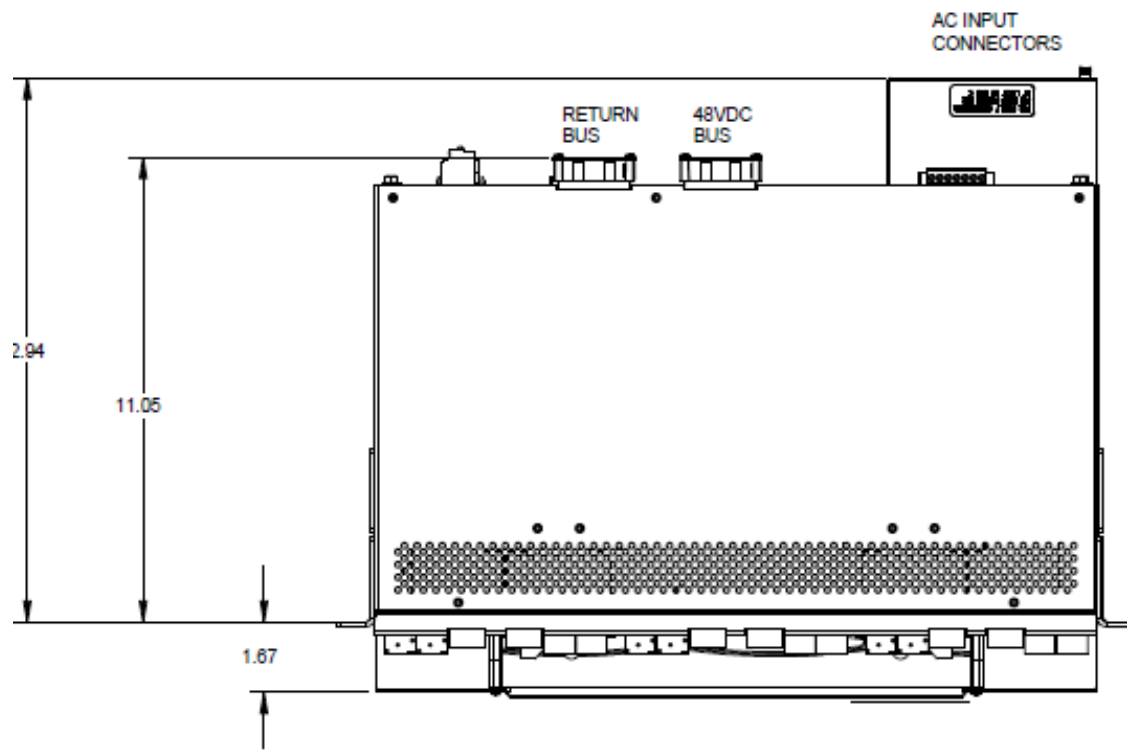



## DIN Rail Circuit Breaker Systems

- Order configured systems from the factory or assemble shelves in the field
- DIN battery and load breakers up to 200A with M6 and M8 single hole returns
- Distribution rate for 200A (150A with LVD)



## Factory Configured Systems

Ordering Code	Description	Rectifier Slots	Load Breaker Positions	Battery Breaker Positions	LVD
150040505	SPS-5U-AC5-PS6-DIN20B	6	20	4	No
150040506	SPS-5U-AC5-PS6-DIN20B-LVBD	6	20	4	LVBD
150040507	SPS-5U-AC5-PS6-DIN20B-LVLD	6	20	4	LVLD
150040508	SPS-5U-AC5-PS6-DIN20B-LVBD-LVLD	6	20	4	LVBD, LVLD

## Separate Distributions

The following codes are the base distributions used in Factory Configured Systems. These codes may be ordered separately by integrators for building customer specific solutions in the field. These distributions have their own safety certification.

### 3RU DIN Rail Distribution Shelves

Ordering Code	Model	Breaker	Battery Breaker Positions	LVD
150030916	J2012001L011	20	4 (8 poles)	None
150030918	J2012001L011B	20	4 (8 poles)	LVBD (150A)
150038051	J2012001L011L	20 (8 Priority, 12 Non-Priority)	4 (8 poles)	LVLD (150A)
150038052	J2012001L011BL	20 (8 Priority, 12 Non-Priority)	4 (8 poles)	LVBD & LVLD (150A)

## Rectifier Shelves

The following codes are for adding additional rectifier shelves to Infinity S plants in the field. Each kit includes: Rectifier shelf with mounting hardware, busbar interconnects with hardware and inter-shelf communication cable. Note: Adding these shelves does not increase the overall rating of the distribution.

### 1RU Rectifier Shelves

Ordering Code	Description	AC Input	Rectifier Slots	Controller Support	DC Output
150028853	J2007003L051C	Rear AC Terminal	3	Yes	Rear Bulk
150028854	J2007003L052C	Rear AC Terminal	3	No	Rear Bulk

# DIN Rail Circuit Breaker Systems - Drawings

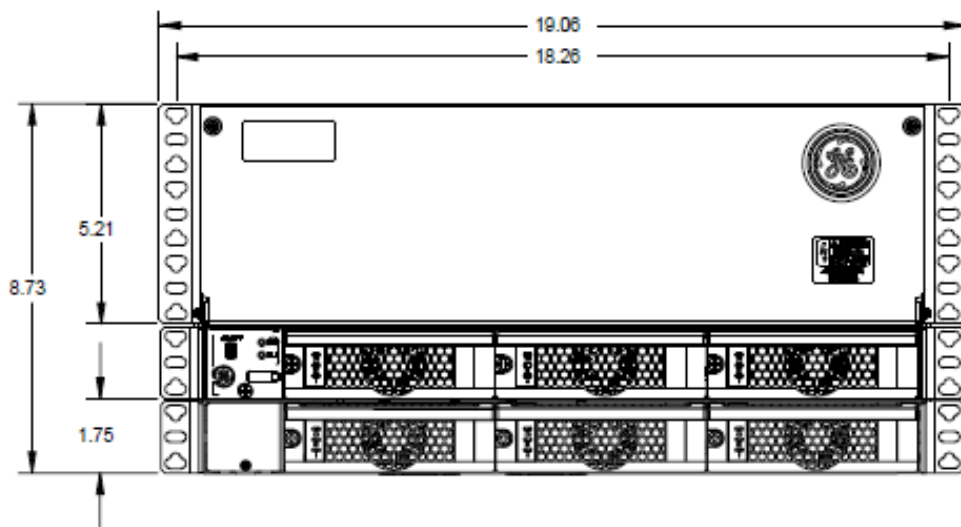
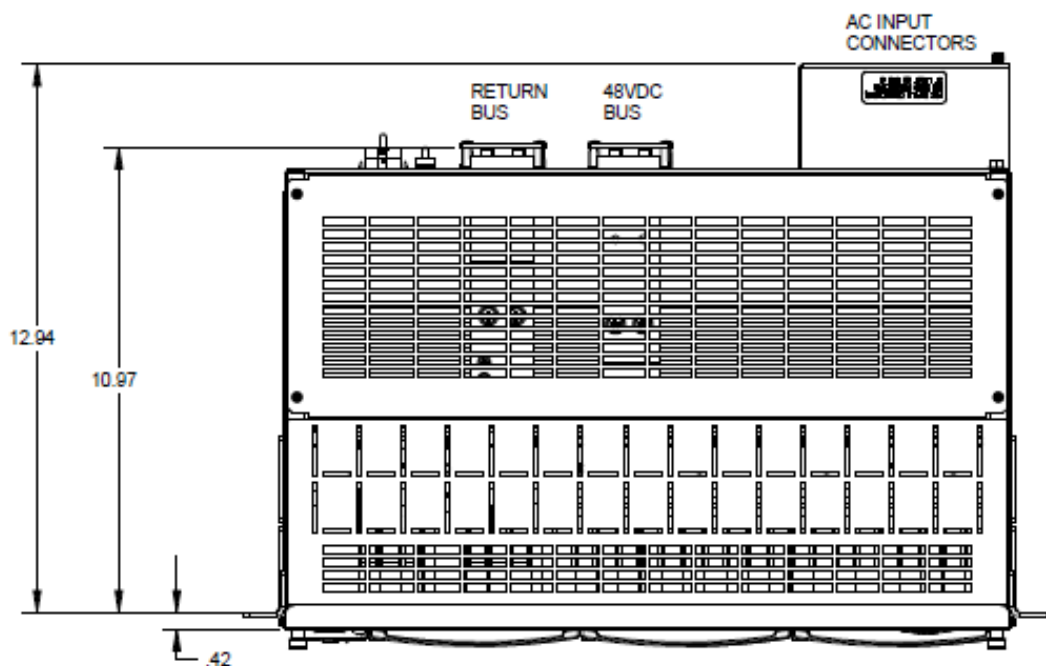



# Common System Components

## Rectifiers

Ordering Code	Description
150027894	EP0500-UTEZ 500W
CC109165602	EP1000-UTEZ 1000W
CC109165610	EP1600-UTEZ 1600W
CC848883297	Slot Filler

## Controllers

Ordering Code	Description
150039821	SPS841A_3C3R_USB_DS
150038227	SPS841A_0I6R_USB_DS (with Display)
CC848868554	Slot Filler (List 1, 1A only)
150039814	SPS841A_960R_USB_S (no Display)

## Battery Management Accessories

Ordering Code	Description
CC109142980	A: QS873A Thermal Probe
CC109166402	A: QS873A Thermal Probe with ES 12-12 battery quick connect kit
CC848817024	B: 10' probe to controller wire set
CC109157434	B: 20' probe to controller wire set
CC848822560	C: 1' probe to probe wire set
848719803	C: 5' probe to probe wire set
CC848822321	C: 10' probe to probe wire set
108958422	ES771A Voltage Monitor Card
CC848791517	D: 2 1/2' ES771A to probe wire set
CC848797290	D: 6' ES771A to probe wire set
848719829	D: 10' ES771A to probe wire set
CC848791500	G: 4' ES771A to ES771A or controller wire set
848652947	G: 10' ES771A to ES771A or controller wire set

E COUPLER 555052-1 AND G-STYLE CABLE TO  
DAISY CHAIN B-STYLE CABLE UP TO 150 FEET

TRIM BROWN VOLTAGE SENSE WIRE ON B AND C-STYLE CABLES

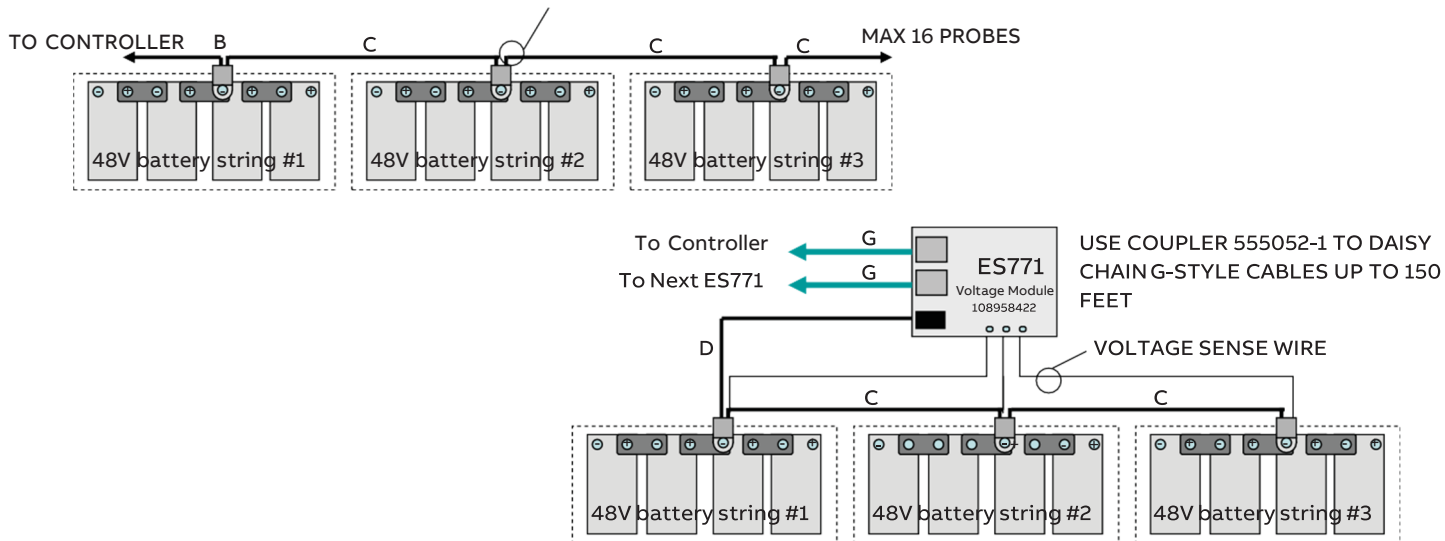

## Common System Components (Cont.)

### Battery Box and Accessories

Ordering Code	Description
CC848903187	SBB12 Wall or Rack Mounted Battery Box (17.4"W x 12.5"D x 5.2"H)
850036438	SBB12w Wall or Rack Mounted Battery Box (17.4"W x 6.7"D x 5.2"H)
CC848870832	SBB40 Wall or Rack Mounted Battery Box (17.4"W x 12.25"D x 10.5"H)
850039612	SBB40w Wall or Rack Mounted Battery Box (17.2"W x 6.7"D x 19.25"H)
850029940	SBB60 Wall or Rack Mounted Battery Box (17.4"W x 15"D x 12.25"H)
408538854	IR-40 Battery, 12V/34AH, #10 bolt, 8.31"L x 5.13"W x 7.00"H, 26 lbs. (4 required for 48V string)
CC408638183	ES12-12 Battery, 12V/12AG, 1/4" Fastons, 5.94"L x 3.86"W x 3.7"H, 9 lbs. (4 required for 48V string)
CC848885715	Wire set, connects one IR-40 string to SPS shelf (10ga, 3-1/2 ft)
850027205	Wire set, connects one battery string with 1/4" M6 connections to SPS shelf (8ga, 3-1/2 ft)
CC848873546	Wires set, connects one or two ES12-12 strings to SPS shelf (12ga, 3-1/2ft)
CC109164471	30A Battery Breaker Disconnect (includes 30A breaker and 10ga wiring for one ES12-12 string)
150022385	30A Battery Breaker Disconnect (includes 30A breaker and 10ga wiring for two ES12-12 strings)
CC109153202	50A Battery Breaker Disconnect (includes 50A breaker and 8ga wiring for one IR-40 string)
850041482	Wall mount bracket 1U, 19"
CC848844803	19" to 23" frame mount bracket kit (1RU)
848683009	19" to 23" frame mount bracket kit (2RU)



CC848870832



CC848903187



850036438



850029940



850041482





850039612

# Distribution Components

## Bullet Style Load Circuit Breakers

Ordering Code	Amperage	CB Positions (Poles)	Photo
407998137	3	1	
407998145	5	1	
407998152	10	1	
407998160	15	1	
407998178	16	1	
407998186	20	1	
407998194	25	1	
407998202	30	1	
408213486	40	1	
407998210	45	1	
407998228	50	1	
407998236	60	1	
407998244	70	1	
407998251	80	1	
407998269	90	1	
407998277	100	1	

## Bullet Style Battery Circuit Breakers (Yellow Handle) (Alarms on Mid-trip and in Off position)

Ordering Code	Amperage	Photo
CC408612758	30	
CC408612766	40	
CC408612774	45	
CC408574370	50	
408560123	60	
CC408574387	70	
CC408574395	100	
CC109106548	100A battery bullet bus strap (substitute for battery breaker)	

## Distribution Components Cont.

### DIN Rail Mounted Breakers

#### DIN Load Breakers

Ordering Code	Current rating	Poles	Ordering Code	Current rating	Poles
450031081	100A	2	450029217	30A	1
450031083	150A	3	450029218	25A	1
450031084	200A	4	450029219	20A	1
450028218	63A	1			
			450029220	15A	1
450029213	50A	1	450029222	10A	1
CC408654288	40A	1	450029223	5A	1
450029214	35A	1	450037914	2A	1

#### DIN Battery Breakers

Ordering Code	Current rating	Poles
150040992	63A	1
150040991	100A	2
150040993	150A	3
150040994	200A	4

#### GMT Fuses

Ordering Code	Amperage	Photo
405006222	0.25A	
3150439	0.5A	
405673146	1.33A	
405181983	2A	
406976985	3A	
406159061	5A	
405725433	7.5A	
406159236	10A	
407845197	12A	
406473959	15A	
408515823	Fuse Puller	
402099436	Dummy Fuse	

## Select Distribution Components, Cont.

### Terminal Lugs for Bullet Style Breakers and TPS Fuses (1/4" bolt on 5/8" centers)

Ordering Code	STR Wire GA (Class B)	Flex Wire GA (Class I)	WP-91412 List	Photo
406021626	8	8	75	
405347519	6	6	3	
405347576	4	4	5	
405348202	2	-	54	
405347683	-	2	8	

### Straight Lug (#10 bolt on 5/8" centers) for DC2, DC3, DC4, DC6 Load Connections

Ordering Code	STR Wire GA (Class B)	Flex Wire GA (Class I)	WP-91412 List	Photo
405356171*	14-10	14-10	73	
405348178*	8	8	52	
406338400*	6	6	108	

---

## Management Visibility

Galaxy Manager\* software is the centralized visibility and control component of a comprehensive power management system designed to meet engineering, operations and maintenance needs. The Galaxy Manager client-server architecture enables remote access to system controllers across the power network.

- Dashboard display with one-click access to management information database
- Trend analysis
- Scheduled or on demand reports
- Fault, configuration, asset, and performance management

## Training

ABB offers on-site and classroom training options based on certification curriculum. Technical training can be tailored to individual customer needs. Training enables customers and partners to more effectively manage and support the power infrastructure. We have built our training program on practical learning objectives that are relevant to specific technologies or infrastructure design objectives.

## Service & Support

ABB field service and support personnel are trusted advisors to our customers always available to answer questions and help with any project, large or small. Our certified professional services team consists of experts in every aspect of power conversion with the resources and experience to handle large turnkey projects along with custom approaches to complex challenges. Proven systems

engineering and installation best practices are designed to safely deliver results that exceed our customers' expectations.

## Warranty

ABB is committed to providing quality products and solutions. We have developed a comprehensive warranty that protects you and provides a simple way to get your products repaired or replaced as soon as possible.

For full warranty terms and conditions please go to [abbpowerconversion.com](http://abbpowerconversion.com)