

The documentation and process conversion measures necessary to comply with this revision shall be completed by 14 January 2014.

INCH-POUND
MIL-PRF-19500/241N
14 November 2013
SUPERSEDING
MIL-PRF-19500/241M
25 January 2010

PERFORMANCE SPECIFICATION SHEET

* SEMICONDUCTOR DEVICE, DIODE, SILICON, LOW LEAKAGE, CONTROLLED FORWARD VOLTAGE, TYPES 1N3595-1, 1N3595UB, 1N3595UBCA, 1N3595UBD, 1N3595UBCC, 1N3595UB2, 1N3595UB2R, 1N3595US, 1N3595UR-1, 1N3595A-1, 1N3595AUS, AND 1N3595AUR-1, JAN, JANTX, JANTXV, JANS, JANHC, AND JANKC

This specification is approved for use by all Departments and Agencies of the Department of Defense.

The requirements for acquiring the product described herein shall consist of this specification sheet and MIL-PRF-19500.

1. SCOPE

1.1 Scope. This specification covers the performance requirements for silicon, controlled forward voltage diodes. Four levels of product assurance are provided for each device type as specified in MIL-PRF-19500. Two levels of product assurance are provided for die.

1.2 Physical dimensions. See [figure 1](#) (DO-35), [figure 2](#) (UR), [figure 3](#) (US), [figure 4](#) (UB), [figure 5](#) (UB2), [figure 6](#) (die), and [figure 7](#) (die).

1.3 Maximum ratings. $T_A = +25^\circ\text{C}$, unless otherwise specified.

V_{RWM}	I_O (1) (2)	I_{FSM} $t_p = 1 \text{ s}$	I_{FSM} $t_p = 1 \mu\text{s}$	$R_{\theta JL}$ $L = .375 \text{ inch}$ (9.53 mm)	$R_{\theta JEC}$ $L = 0$	$R_{\theta JA(PCB)}$	T_J and T_{STG}
<u>V(pk)</u>	<u>mA dc</u>	<u>mA (pk)</u>	<u>A (pk)</u>	<u>°C/W</u>	<u>°C/W</u>	<u>°C/W</u>	<u>°C</u>
125	150	500	4	250	UR 100 UB, UB2 100 US 40	275	-65 to +175

(1) For temperature-current derating curves, see [figure 8](#).

(2) $T_A = +75^\circ\text{C}$ for both axial and metal electrode leadless face diodes (MELF) (UR, US) on printed circuit board (PCB), PCB = FR4 - .0625 inch (1.59 mm) 1-layer 1-Oz Cu, horizontal, in still air; pads for (UR, US) = .061 inch (1.55 mm) x .105 inch (2.67 mm); pads for axial = .092 inch (2.34 mm) diameter, strip = .030 inch (0.76 mm) x 1 inch (25.4 mm) long, lead length $L \leq .187 \text{ inch}$ ($\leq 4.75 \text{ mm}$); $R_{\theta JA}$ with a defined PCB thermal resistance condition included, is measured at $I_O = 150 \text{ mA dc}$.

* Comments, suggestions, or questions on this document should be addressed to Defense Supply Center, Columbus, ATTN: DSCC-VAC, P.O. Box 3990, Columbus, OH 43218-3990, or emailed to semiconductor@dsc.dla.mil. Since contact information can change, you may want to verify the currency of this address information using the ASSIST Online database at <https://assist.dla.mil>.

MIL-PRF-19500/241N

1.4 Primary electrical characteristics at $T_A = +25^\circ\text{C}$, unless otherwise indicated and apply to all parts.

Limits	V_{F1} $I_F = 200 \text{ mA dc}$	V_{F2} $I_F = 100 \text{ mA dc}$	V_{F3} $I_F = 50 \text{ mA dc}$	V_{F4} $I_F = 10 \text{ mA dc}$	V_{F5} $I_F = 5 \text{ mA dc}$	V_{F6} $I_F = 1 \text{ mA dc}$
Min	.83 V dc	.79 V dc	.74 V dc	.65 V dc	.60 V dc	.52 V dc
Max	1.00 V dc	.92 V dc	.88 V dc	.80 V dc	.765 V dc	.70 V dc

Types	I_{R1} $V_R = 125 \text{ V dc}$	I_{R2} $V_R = 125 \text{ V dc}$ $T_A = +150^\circ\text{C}$	C $V_R = 0 \text{ V dc}$ $f = 1 \text{ MHz}$	t_{rr} $I_F = 10 \text{ mA dc}$ $V_R = 35 \text{ V dc}$
	Max	Max	Max	Max
1N3595-1	1.0 nA dc	3 μA dc	8.0 pF	3 μs
1N3595A-1	2.0 nA dc	3 μA dc	8.0 pF	3 μs

2. APPLICABLE DOCUMENTS

2.1 General. The documents listed in this section are specified in sections 3, 4, or 5 of this specification. This section does not include documents cited in other sections of this specification or recommended for additional information or as examples. While every effort has been made to ensure the completeness of this list, document users are cautioned that they must meet all specified requirements of documents cited in sections 3, 4, or 5 of this specification, whether or not they are listed.

2.2 Government documents.

2.2.1 Specifications, standards, and handbooks. The following specifications, standards, and handbooks form a part of this document to the extent specified herein. Unless otherwise specified, the issues of these documents are those cited in the solicitation or contract.

DEPARTMENT OF DEFENSE SPECIFICATIONS

MIL-PRF-19500 - Semiconductor Devices, General Specification for.

DEPARTMENT OF DEFENSE STANDARDS

MIL-STD-750 - Test Methods for Semiconductor Devices.

* (Copies of these documents are available online at <http://quicksearch.dla.mil> or <https://assist.dla.mil> or from the Standardization Document Order Desk, 700 Robbins Avenue, Building 4D, Philadelphia, PA 19111-5094.)

2.3 Order of precedence. Unless otherwise noted herein or in the contract, in the event of a conflict between the text of this document and the references cited herein, the text of this document takes precedence. Nothing in this document, however, supersedes applicable laws and regulations unless a specific exemption has been obtained.

3. REQUIREMENTS

3.1 General. The individual item requirements shall be as specified in MIL-PRF-19500 and as modified herein.

3.2 Qualification. Devices furnished under this specification shall be products that are manufactured by a manufacturer authorized by the qualifying activity for listing on the applicable qualified manufacturers list (QML) before contract award (see 4.2 and 6.3).

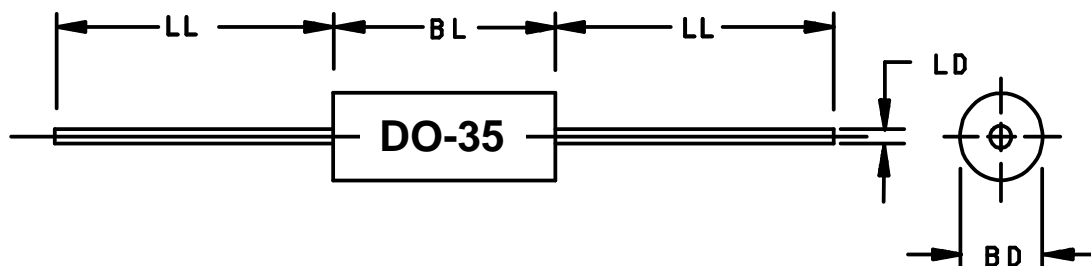

Ltr	Dimensions			
	Inches		Millimeters	
	Min	Max	Min	Max
BD	.056	.075	1.42	1.91
BL	.140	.180	3.56	4.57
LD	.018	.022	0.46	0.56
LL	1.000	1.500	25.40	38.10

NOTES:

1. Dimensions are in inches.
2. Millimeters are given for general information only.
3. In accordance with ASME Y14.5M, diameters are equivalent to Φ x symbology.

FIGURE 1. Physical dimensions - 1N3595-1, 1N3595A-1 (DO-35).

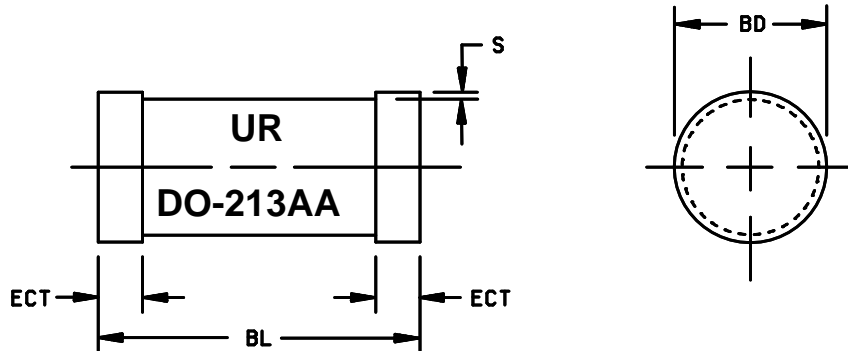

Symbol	Dimensions			
	Inches		Millimeters	
	Min	Max	Min	Max
BD	.063	.067	1.60	1.70
BL	.130	.146	3.30	3.70
ECT	.016	.022	0.41	0.55
S	.001 min		0.03 min	

NOTES:

1. Dimensions are in inches.
2. Millimeters are given for general information only.
3. Dimensions are pre-solder dip.
4. Referencing to dimension S, minimum clearance of glass body to mounting surface on all orientations.
5. In accordance with ASME Y14.5M, diameters are equivalent to Φx symbology.

FIGURE 2. Physical dimensions 1N3595UR-1, 1N3595AUR-1 (DO-213AA).

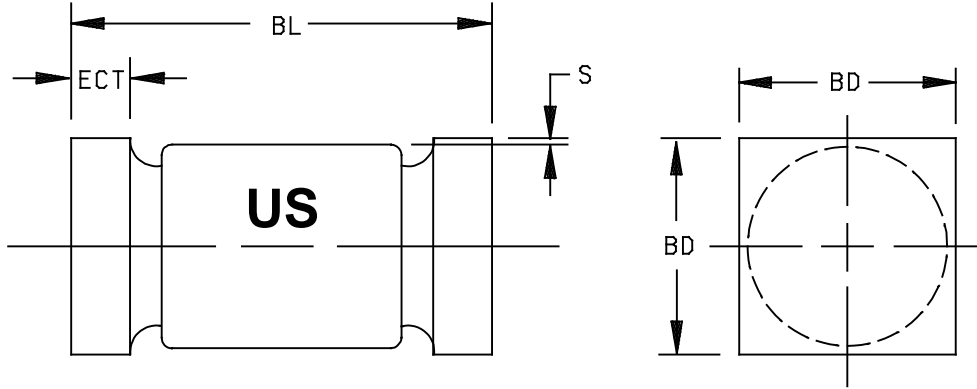

Ltr	Dimensions			
	Inches		Millimeters	
	Min	Max	Min	Max
BD	.070	.085	1.78	2.16
BL	.165	.195	4.19	4.95
ECT	.019	.028	0.48	0.71
S	.003		0.08	

NOTES:

1. Dimensions are in inches.
2. Millimeters are given for general information only.
3. Dimensions are presolder dip.
4. Referencing dimension S, minimum clearance of glass body to mounting surface on all orientations.
5. In accordance with ASME Y14.5M, diameters are equivalent to Φ x symbology.

FIGURE 3. Physical dimensions - 1N3595US, 1N3595AUS.

MIL-PRF-19500/241N

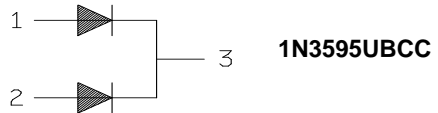
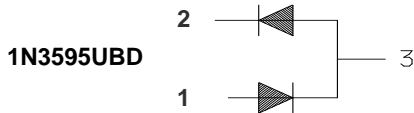
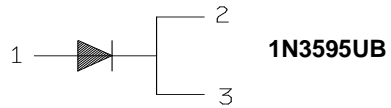
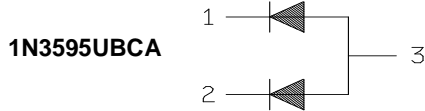
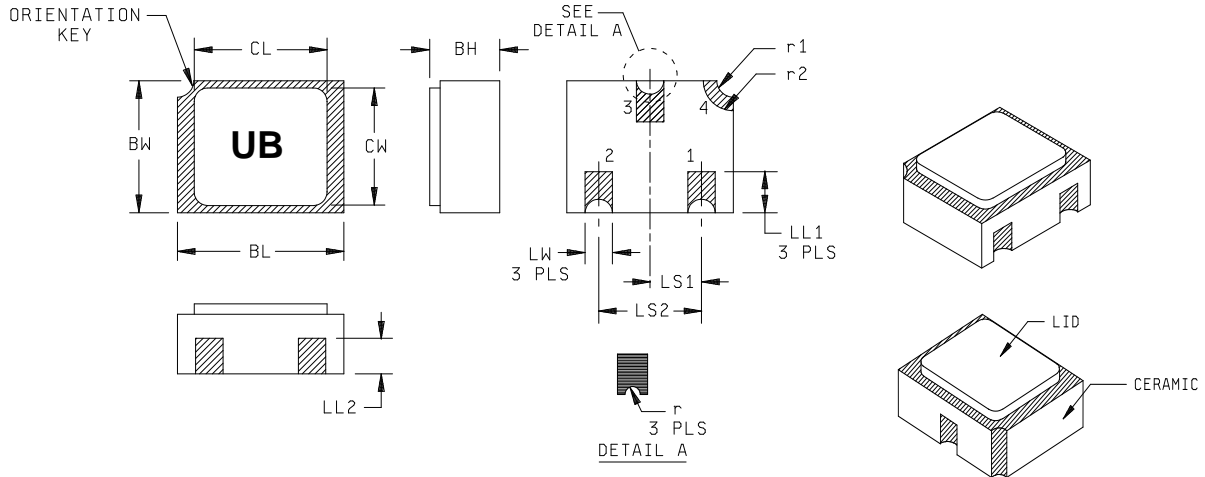

Symbol	Dimensions				Symbol	Dimensions			
	Inches		Millimeters			Inches		Millimeters	
	Min	Max	Min	Max		Min	Max	Min	Max
BH	.046	.056	1.17	1.42	LS1	.035	.039	0.89	0.99
BL	.115	.128	2.92	3.25	LS2	.071	.079	1.80	2.01
BW	.085	.108	2.16	2.74	LW	.016	.024	0.41	0.61
CL		.128		3.25	r		.008		0.20
CW		.108		2.74	r1		.012		0.31
LL1	.022	.038	0.56	0.97	r2		.022		0.56
LL2	.017	.035	0.43	0.89					

NOTES:

1. Dimensions are in inches. Millimeters are given for general information only.
2. Ceramic package only.
3. Hatched areas on package denote metallized areas. Pad 4 = shielding, connected to the lid.
4. Dimensions are pre-solder dip.
5. In accordance with ASME Y14.5M, diameters are equivalent to Φ x symbology.

* FIGURE 4. Physical dimensions, surface mount (UB version).

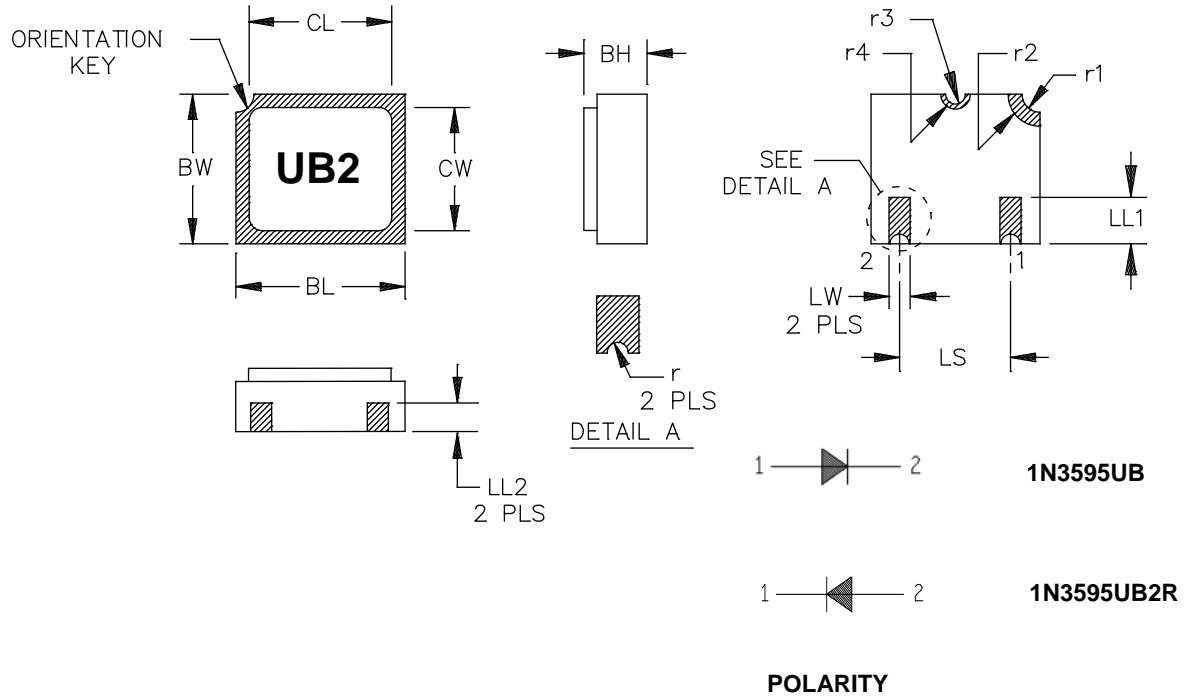

Symbol	Dimensions				Symbol	Dimensions			
	Inches		Millimeters			Inches		Millimeters	
	Min	Max	Min	Max		Min	Max	Min	Max
BH	.046	.056	1.17	1.42	LS	.071	.079	1.80	2.01
BL	.115	.128	2.92	3.25	LW	.016	.024	0.41	0.61
BW	.085	.108	2.16	2.74	r	.008 TYP		0.20 TYP	
CL		.128		3.25	r1	.012 TYP		0.30 TYP	
CW		.108		2.74	r2	.022 TYP		0.56 TYP	
LL1	.022	.038	0.56	0.96	r3	.008 TYP		0.20 TYP	
LL2	.014	.035	0.36	0.89	r4	.012 TYP		0.30TYP	

NOTES:

1. Dimensions are in inches. Millimeters are given for general information only.
2. Ceramic package only.
3. Hatched areas on package denote metallized areas. Pad 4 = shielding, connected to the lid.
4. Dimensions are pre-solder dip.
5. In accordance with ASME Y14.5M, diameters are equivalent to Φx symbology.

* FIGURE 5. Physical dimensions, surface mount (2 pin UB version).

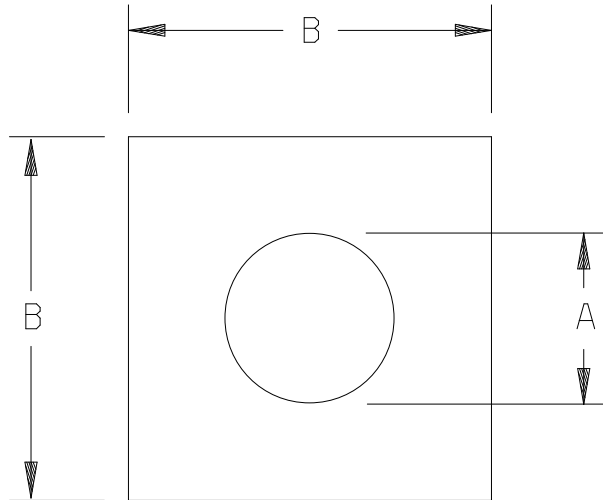

Ltr	Dimensions			
	Inches		Millimeters	
	Min	Max	Min	Max
A	.0079	.0081	0.200	0.206
B	.0145	.0195	0.368	0.495

NOTES:

1. Dimensions are in inches.
2. Millimeters are given for general information only.
3. Element evaluation performed utilizing a TO-5 header.
4. The physical characteristics of the die are:

Metallization:

Top (Anode): Aluminum (Al) 25,000 Å minimum.

Back (Cathode): Gold (Au) 4,000 Å minimum.

Die thickness: .009 inch (0.23 mm) ±.002 inch (±0.051 mm).

FIGURE 6. Physical dimensions JANHCB and JANKCB die.

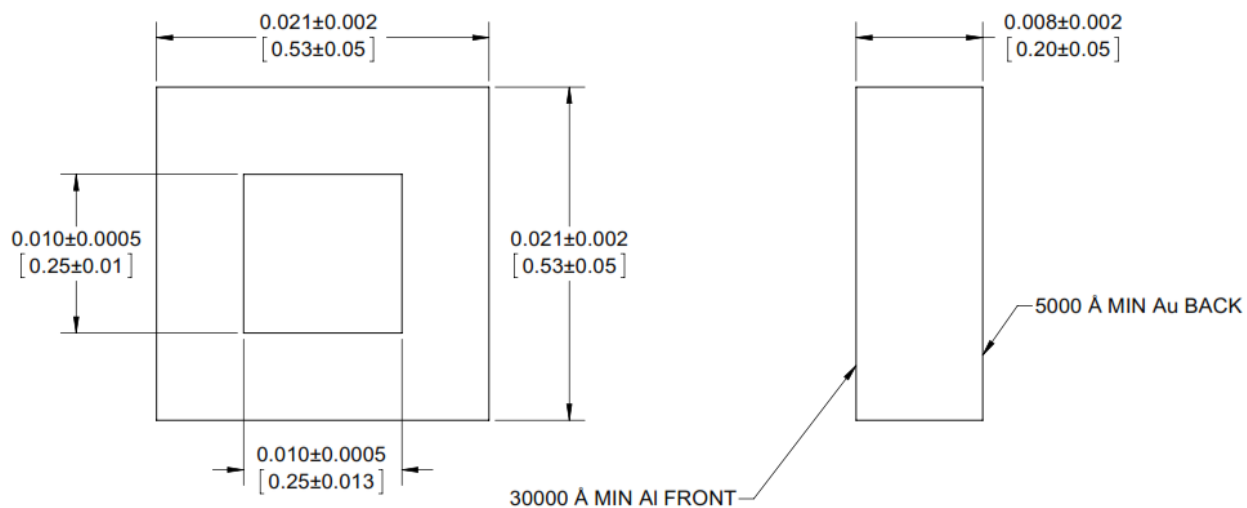

NOTES:

1. Dimensions are in inches.
2. Millimeters are given for general information only.
3. Element evaluation performed utilizing a UB header.
4. The physical characteristics of the die are:

Metallization:

Top (Anode): Aluminum (Al) 30,000 Å minimum.

Back (Cathode): Gold (Au) 5,000 Å minimum.

Die thickness: .008 inch (0.20 mm) ±.002 inch (±0.05 mm).

* FIGURE 7. Physical dimensions JANHCC and JANKCC die.

3.3 Abbreviations, symbols, and definitions. Abbreviations, symbols, and definitions used herein shall be as specified in MIL-PRF-19500 and as follows.

V_{fr} Forward recovery voltage. Specified maximum forward voltage used to determine forward recovery time.

3.4 Interface and physical dimensions. Interface and physical dimensions shall be as specified in MIL-PRF-19500, and on figures 1 (DO-35), 2 (DO-213AA), 3 (US), 4 (UB), 5 (UB2), 6 (die), and 7 (die).

3.4.1 Lead finish. Lead finish shall be solderable in accordance with MIL-PRF-19500, MIL-STD-750, and herein. Where a choice of lead finish is desired, it shall be specified in the acquisition document (see 6.2).

3.4.2 Diode construction. All devices shall be metallurgically bonded, double plug construction in accordance with the requirements of MIL-PRF-19500. All glass diodes shall be designed with sufficient thermal compensation in the axial direction to optimize tensile and compressive stresses. Dimensional analysis is required of all materials used to achieve axial thermal compensation. Dimensional tolerances and corresponding coefficient of thermal expansion (CTE) shall be documented on the DSCC Design and Construction Form 36D and shall be approved by the qualifying activity to maintain qualification. Dimensional tolerances shall be sufficiently tight enough to prevent excessive stresses due to the inherent CTE mismatch. The UR version shall be structurally identical to the axial leaded versions except for end-cap lead attachment. The 'US' version shall be metallurgically bonded, thermally matched, non-cavity, double-plug construction in accordance with the requirements of category I (see MIL-PRF-19500).

3.4.3 JANS construction. All JANS devices shall be metallurgically bonded-thermally matched non-cavity double plug constructions utilizing only category I metallurgical bond in accordance with MIL-PRF-19500.

3.5 Marking. Marking shall be in accordance with MIL-PRF-19500. Manufacturer's identification and date code shall be marked on the devices. Initial container package marking shall be in accordance with MIL-PRF-19500. The polarity shall be indicated with a contrasting color band to denote the cathode end. The prefixes JAN, JANTX, and JANTXV can be abbreviated as J, JX, JV, and JS respectively. The part number may be reduced to J3595A, JX3595A, JV3595A, or JS3595A. No color coding shall be permitted for part numbering.

3.5.1 UR and US devices. For 'UR' and 'US' version devices only, all marking, except polarity may be omitted from the body, but shall be retained on the initial container. Polarity marking of 'UR' and 'US' devices shall consist as a minimum, a band or 3 contrasting dots around the periphery of the cathode.

3.6 Electrical performance characteristics. Unless otherwise specified herein, the electrical performance characteristics are as specified in 1.3, 1.4, and table I.

3.7 Electrical test requirements. The electrical test requirements shall be as specified in table I herein.

3.8 Workmanship. Semiconductor devices shall be processed in such a manner as to be uniform in quality and shall be free from other defects that will affect life, serviceability, or appearance.

4. VERIFICATION

4.1 Classification of inspections. The inspection requirements specified herein are classified as follows:

- a. Qualification inspection (see 4.2).
- b. Screening (see 4.3).
- c. Conformance inspection (see 4.4).

4.2 Qualification inspection. Qualification inspection shall be in accordance with MIL-PRF-19500 and as specified herein.

4.2.1 Group E qualification. Group E inspection shall be performed for qualification or re-qualification only. In case qualification was awarded to a prior revision of the specification sheet that did not require the performance of [table II](#) tests, the tests specified in [table II](#) herein that were not performed in the prior revision shall be performed on the first inspection lot of this revision to maintain qualification.

4.3 Screening (JANS, JANTXV, JANTX, and JAN levels). Screening shall be in accordance with table E-IV of MIL-PRF-19500 and as specified herein. Specified electrical measurements shall be made in accordance with [table I](#) herein. Devices that exceed the limits of [table I](#) herein shall not be acceptable.

Screening (see table E-IV of MIL-PRF-19500)	JANS	JANTXV and JANTX level
1a 1b	Required. Required.	Not required. Required (JANTXV only).
3a	Temperature cycling.	Required.
(1) 3c	Thermal impedance (see 4.3.3).	Thermal impedance (see 4.3.3).
9	I_{R1} and V_{F1} .	Not required.
10	Method 1038 of MIL-STD-750, condition A.	Method 1038 of MIL-STD-750, condition A.
(2) 11	I_{R1} , V_{F1} , $\Delta V_{F1} \leq \pm 50$ mV change from initial value. $\Delta I_{R1} \leq \pm 0.5$ nA dc, or ≤ 100 percent whichever is greater.	I_{R1} , V_{F1} .
12	See 4.3.2 . $t = 240$ hours minimum.	See 4.3.2 .
(3) (4) 13	Subgroups 2 and 3 of table I herein; $\Delta V_{F1} \leq \pm 50$ mV change from initial value. $\Delta I_{R1} \leq \pm 0.5$ nA dc, or ≤ 100 percent whichever is greater.	Subgroup 2 of table I herein; $\Delta V_{F1} \leq \pm 50$ mV change from initial value. $\Delta I_{R1} \leq \pm 0.5$ nA dc, or ≤ 100 percent whichever is greater.

- (1) Thermal impedance shall be performed any time after sealing provided temperature cycling is performed in accordance with MIL-PRF-19500, screen 3 prior to this thermal test.
- (2) Test within 24 hours after removal from test.
- (3) When thermal impedance is performed prior to screen 13, it is not required to be repeated in screen 13.
- (4) PDA ≤ 5 percent.

4.3.1 Screening (JANH C and JANKC). Screening of JANHC and JANKC die shall be in accordance with appendix G of MIL-PRF-19500. Burn-in duration for the JANKC level follows JANS requirements; the JANHC follows JANTX requirements.

4.3.1.1 JAN testing. JAN level product which is either category II or III shall have temperature cycling and thermal impedance testing performed in accordance with MIL-PRF-19500, JANTX level screening level requirements. Electrical testing shall be in accordance with table I, subgroup 2 herein.

4.3.2 Power burn-in conditions. Power burn-in conditions are as follows (see [4.5.2](#)): Method 1038 of MIL-STD-750, condition B. $V_R =$ rated V_{RWM} ; $f = 50-60$ Hz; $I_O = 150$ mA dc or $I_F = 150$ mA dc minimum. $T_A = 75^\circ\text{C}$ maximum. The maximum current density of small die shall be submitted to the qualifying activity for approval. Alternate mounting conditions shall be submitted to the qualifying activity for approval. With approval of the qualifying activity and preparing activity, alternate burn-in criteria (hours, bias conditions, and mounting conditions) may be used. A justification demonstrating equivalence is required. In addition, the manufacturing site's burn-in data and performance history will be essential criteria for burn-in modification approval.

MIL-PRF-19500/241N

4.3.3 Thermal impedance. The thermal impedance measurements shall be performed in accordance with method 3101 or 4081 of MIL-STD-750 using the guidelines in that method for determining I_M , I_H , t_H , t_{SW} (V_C and V_H where appropriate). Measurement delay time (t_{MD}) = 70 μ s max. The thermal impedance limit used in screen 3c and [table I](#), subgroup 2 shall be set statistically by the supplier.

4.4 Conformance inspection. Conformance inspection shall be in accordance with MIL-PRF-19500 and as specified herein.

4.4.1 Group A inspection. Group A inspection shall be conducted in accordance with table E-V of MIL-PRF-19500, [table I](#) herein, and as specified herein. Electrical measurements (end-points) shall be in accordance with [table I](#), subgroup 2 herein.

4.4.2 Group B inspection. Group B inspection shall be conducted in accordance with the conditions specified for subgroup testing in tables E-VIa (JANS) and E-VIb (JAN, JANTX, and JANTXV) of MIL-PRF-19500 and [4.4.2.1](#) and [4.4.2.2](#) herein. Electrical measurements (end-points) shall be in accordance with [table I](#), subgroup 2 herein.

4.4.2.1 Group B inspection, table E-VIa (JANS) of MIL-PRF-19500.

<u>Subgroup</u>	<u>Method</u>	<u>Condition</u>
B4	1037	$V_R = 125$ V(pk); $T_A =$ room ambient as defined in the general requirements of MIL-STD-750; $I_O = 150$ mA dc; $t_{on} = t_{off} = 3$ minutes minimum for 2,000 cycles.
B5	1027	$V_{(pk)} =$ rated V_{RWM} , $I_O = 150$ mA (min), adjust T_A or I_O to obtain a minimum T_J of +175°C.
B6	4081	$L = .375$ inch (9.53 mm); $R_{\theta JL} = 250^\circ\text{C/W}$ maximum, $R_{\theta JEC} = 40^\circ\text{C/W}$ maximum for US, $R_{\theta JEC} = 100^\circ\text{C/W}$ maximum for UR. (See 4.3.3.)

4.4.2.2 Group B inspection, table E-VIb (JAN, JANTX, and JANTXV) of MIL-PRF-19500. Leaded samples from the same lot may be used in lieu of 'UR' or 'US' suffix sample for life test.

<u>Subgroup</u>	<u>Method</u>	<u>Conditions</u>
B2	1056	0°C to +100°C, 10 cycles.
B2	1051	-55°C to +175°C, 45 cycles, including screening.
B2	2005	$I_F = 100$ mA, axial tensile stress = 8 lbs, $T_A = +150^\circ\text{C}$; (not applicable to 'UR' or 'US' package).
B3	1026	$V_{(pk)} =$ rated V_{RWM} ; $f = 50 - 60$ Hz; $I_O = 150$ mA dc minimum; adjust T_A or I_O to obtain a minimum T_J of +150°C. (See 4.5.2.)
B4	2101	Decap analysis; scribe and break only.
B5	4081	$L = .375$ inch (9.53 mm); $R_{\theta JL} = 250^\circ\text{C/W}$ maximum, $R_{\theta JEC} = 40^\circ\text{C/W}$ maximum for US, $R_{\theta JEC} = 100^\circ\text{C/W}$ maximum for UR. (See 4.3.3.)
B6	1032	$T_A = +175^\circ\text{C}$.

MIL-PRF-19500/241N

4.4.3 Group C inspection. Group C inspection shall be conducted in accordance with the conditions specified for subgroup testing in table E-VII of MIL-PRF-19500, and as follows. Electrical measurements (end-points) shall be in accordance with [table I](#), subgroup 2 and [table III](#) herein.

4.4.3.1 Group C inspection, table E-VII of MIL-PRF-19500.

<u>Subgroup</u>	<u>Method</u>	<u>Conditions</u>
C2	1056	0°C to + 100°C, 10 cycles.
C2	1051	-55°C to + 175°C, 45 cycles including screening.
*	C2	2036 Axial devices - Tension: Condition A, 10 pounds, t = 15 s. Lead fatigue: Condition E.
*	C2	2036 US devices - Tension: Condition A, 10 pounds, t = 15 s. Suitable fixtures may be used to pull the end-caps in a manner which does not aid construction. Reference to axial lead may be interpreted as end-cap with fixtures used for mounting. (Tension is not applicable to 'UR' suffix types) (Lead fatigue is not applicable to US and UR suffix types).
C5		Not applicable.
C6	1026	1,000 hours minimum, $V_{pk} = \text{rated } V_{RWM}$; $f = 50 - 60 \text{ Hz}$; $I_O = 150 \text{ mA dc}$ minimum; adjust T_A or I_O to obtain a minimum T_J of +150°C. (See 4.5.2.)

4.4.4 Group E inspection. Group E inspection shall be conducted in accordance with the tests and conditions specified for subgroup testing in table E-IX of MIL-PRF-19500, and [table II](#) herein. Electrical measurements (end-points) shall be in accordance with [table I](#), subgroup 2 herein.

4.5 Methods of inspection. Methods of inspection shall be as specified in the appropriate tables and as follows.

4.5.1 Pulse measurements. Conditions for pulse measurements shall be as specified in section 4 of MIL-STD-750.

4.5.2 Free air power burn-in and life tests. The use of a current limiting or ballast resistor is permitted provided that each device under test still sees the full P_t (minimum) and that the minimum applied voltage, where applicable, is maintained throughout the burn-in period. Method 3100 of MIL-STD-750 shall be used to measure T_J .

MIL-PRF-19500/241N

TABLE I. Group A inspection.

Inspection <u>1/</u> <u>2/</u>	MIL-STD-750		Symbol	Limits		Unit
	Method	Conditions		Min	Max	
<u>Subgroup 1</u>						
Visual and mechanical examination	2071					
<u>Subgroup 2</u>						
Thermal impedance	3101	See 4.3.3	Z _{θJX}		70	°C /W
Forward voltage	4011	I _F = 200 mA dc	V _{F1}	.83	1.00	V dc
Forward voltage	4011	I _F = 100 mA dc	V _{F2}	.79	.92	V dc
Forward voltage	4011	I _F = 50 mA dc	V _{F3}	.74	.88	V dc
Forward voltage	4011	I _F = 10 mA dc	V _{F4}	.65	.80	V dc
Forward voltage	4011	I _F = 5 mA dc	V _{F5}	.60	.765	V dc
Forward voltage	4011	I _F = 1 mA dc	V _{F6}	.52	.70	V dc
Reverse current 1N3595 1N3595A	4016	DC method, V _R = 125 V dc	I _{R1}		1.0 2.0	nA dc nA dc
<u>Subgroup 3</u>						
High temperature operation		T _A = +150°C				
Reverse current	4016	DC method; V _R = 125 V dc	I _{R2}		3.0	μA dc
Low temperature operation		T _A = -55°C				
Breakdown voltage	4021	I _R = 100 μA dc	V(BR)	150		V dc

See footnotes at end of table.

MIL-PRF-19500/241N

TABLE I. Group A inspection - Continued.

Inspection <u>1/</u> <u>2/</u>	MIL-STD-750		Symbol	Limits		Unit
	Method	Conditions		Min	Max	
<u>Subgroup 4</u>						
Capacitance	4001	$V_R = 0$ V dc, $f = 1$ MHz	C		8.0	pF
Reverse recovery time	4031	Condition A, $I_F = 10$ mA dc, $V_R = 35$ V dc, $R = 1,000 \Omega$, .6 uF (for test setup only, recover to 100 k Ω)	t_{rr}		3	μ s
<u>Subgroup 5</u>						
Not applicable						
<u>Subgroup 6</u>						
Surge current	4066	$I_O = 150$ mA dc, $I_{FSM} = 0.50$ A, ten 1 second surges, one surge per minute				
Electrical measurements		See table I , group A, subgroup 2 herein				
<u>Subgroup 7</u>						
Not applicable						

1/ For sampling plan, see MIL-PRF-19500.

2/ Electrical characteristics for all surface mount versions are identical to the corresponding axial leaded versions unless otherwise specified.

MIL-PRF-19500/241N

TABLE II. Group E inspection (all quality levels) for qualification and requalification only.

Inspection	MIL-STD-750		Qualification inspection
	Method	Conditions	
<u>Subgroup 1</u>			n = 45, c = 0
Thermal shock (glass strain)	1056	100 cycles 0°C to 100°C.	
Temperature cycling	1051	500 cycles, -65°C to +175°C.	
Hermetic seal	1071	Gross leak only.	
Electrical measurements		See table I , subgroup 2.	
<u>Subgroup 2</u>			
Intermittent operating life	1037	10,000 cycles; I _F = I _O = 150 mA dc, T _{ON} = T _{OFF} = 1 minute	
Electrical measurements		See table I , subgroup 2.	
<u>Subgroup 4</u>			
Thermal impedance curves		See MIL-PRF-19500.	
<u>Subgroup 5</u>			
Not applicable			
<u>Subgroup 6</u>			
* ESD	1020		
<u>Subgroup 8</u>			
Resistance to glass cracking	1057	Test condition B. Test until failure occurs or to a maximum of 25 cycles, whichever comes first.	n = 45
<u>Subgroup 9</u>			
Monitored mission temperature cycling	1055		n = 22, c = 0
Electrical measurements		See table I , subgroup 2.	

MIL-PRF-19500/241N

TABLE III. Groups B and C delta measurements. 1/ 2/

Step	Inspection <u>1/</u>	MIL-STD-750		Symbol	Limits	
		Method	Conditions		Min	Max
1.	Forward voltage	4011	$I_F = 200 \text{ mA dc}$	ΔV_{F1}	≤ 50 mV change from initial value.	
2	Reverse current	4016	DC method; $V_R = 125 \text{ V dc}$	ΔI_{R1}	≤ 100 percent of initial value or 0.1 nA dc, whichever is greater.	

1/ The delta measurements for table E-VIa (JANS) of MIL-PRF-19500 are as follows:

- a. Subgroup 4, see [table III](#) herein, steps 1 and 2.
- b. Subgroup 5, see [table III](#) herein, steps 1 and 2.

2/ The delta measurements for table E-VII of MIL-PRF-19500 are as follows: Subgroup 6, see [table III](#) herein, steps 1 and 2 (JANS only).

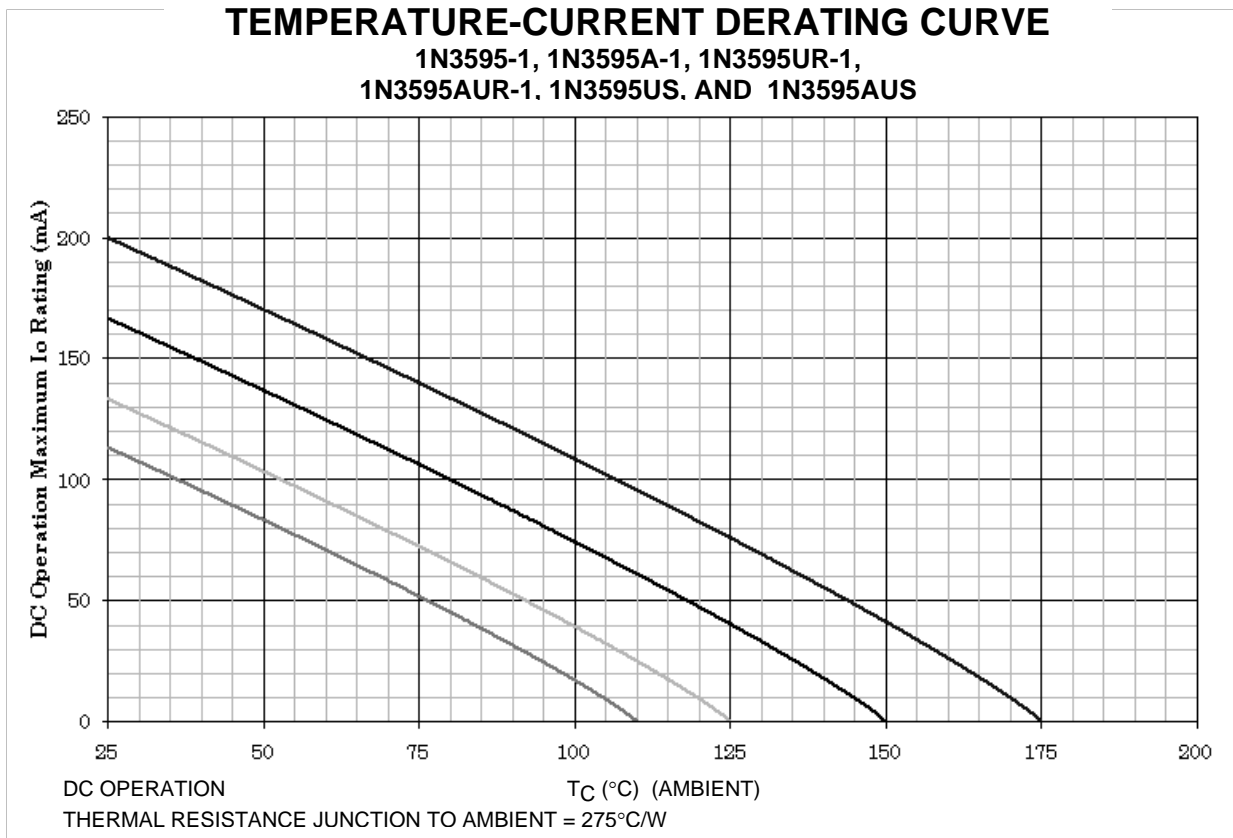
**NOTES:**

1. This is the true inverse of the worst case thermal resistance value. All devices are capable of operating at $\leq T_J$ specified on this curve. Any parallel line to this curve will intersect the appropriate power for the desired maximum T_J allowed.
2. Derate design curve constrained by the maximum junction temperature ($T_J \leq 175^\circ\text{C}$) and power/current rating specified. (See 1.3 herein.)
3. Derate design curve chosen at $T_J \leq 150^\circ\text{C}$, where the maximum temperature of electrical test is performed.
4. Derate design curves chosen at $T_J \leq 125^\circ\text{C}$, and 110°C to show power/current rating where most users want to limit T_J in their application.

FIGURE 8. Temperature-current derating graph.

5. PACKAGING

5.1 Packaging. For acquisition purposes, the packaging requirements shall be as specified in the contract or order (see 6.2). When packaging of materiel is to be performed by DoD or in-house contractor personnel, these personnel need to contact the responsible packaging activity to ascertain packaging requirements. Packaging requirements are maintained by the Inventory Control Point's packaging activities within the Military Service or Defense Agency, or within the Military Service's system commands. Packaging data retrieval is available from the managing Military Department's or Defense Agency's automated packaging files, CD-ROM products, or by contacting the responsible packaging activity.

6. NOTES

(This section contains information of a general or explanatory nature that may be helpful, but is not mandatory. The notes specified in MIL-PRF-19500 are applicable to this specification.)

6.1 Intended use. Semiconductors conforming to this specification are intended for original equipment design applications and logistic support of existing equipment.

6.2 Acquisition requirements. Acquisition documents should specify the following:

- a. Title, number, and date of this specification.
- b. Packaging requirements (see 5.1).
- c. Lead finish (see 3.4.1).
- d. Product assurance level and type designator.
- e. Destructive physical analysis when requested.

* 6.3 Qualification. With respect to products requiring qualification, awards will be made only for products which are, at the time of award of contract, qualified for inclusion in Qualified Manufacturers List (QML-19500) whether or not such products have actually been so listed by that date. The attention of the contractors is called to these requirements, and manufacturers are urged to arrange to have the products that they propose to offer to the Federal Government tested for qualification in order that they may be eligible to be awarded contracts or orders for the products covered by this specification. Information pertaining to qualification of products may be obtained from Defense Supply Center, Columbus, ATTN: DSCC/VQE, P.O. Box 3990, Columbus, OH 43218-3990 or e-mail vqe.chief@dla.mil. An online listing of products qualified to this specification may be found in the Qualified Products Database (QPD) at <https://assist.dla.mil>.

* 6.4 Suppliers of JANHC die. The qualified JANHC suppliers with the applicable letter version (example JANHCB1N3595) will be identified on the QML.

PIN	JANC ordering information	
	Manufacturer - 43611	Manufacturer - 34156
1N3595	JANHCB1N3595	JANHCC1N3595
1N3595	JANKCB1N3595	JANKCC1N3595

6.4.1 Substitutability. The following shows the direct substitutability.

Superseded part number	Superseding part number
1N3595	1N3595-1
1N3595US-1	1N3595US