

Apr.1.2020 Copyright 2020 HIROSE ELECTRIC CO., LTD. All Rights Reserved.  
In case of consideration for using Automotive equipment / device which demand high reliability, kindly contact our sales window

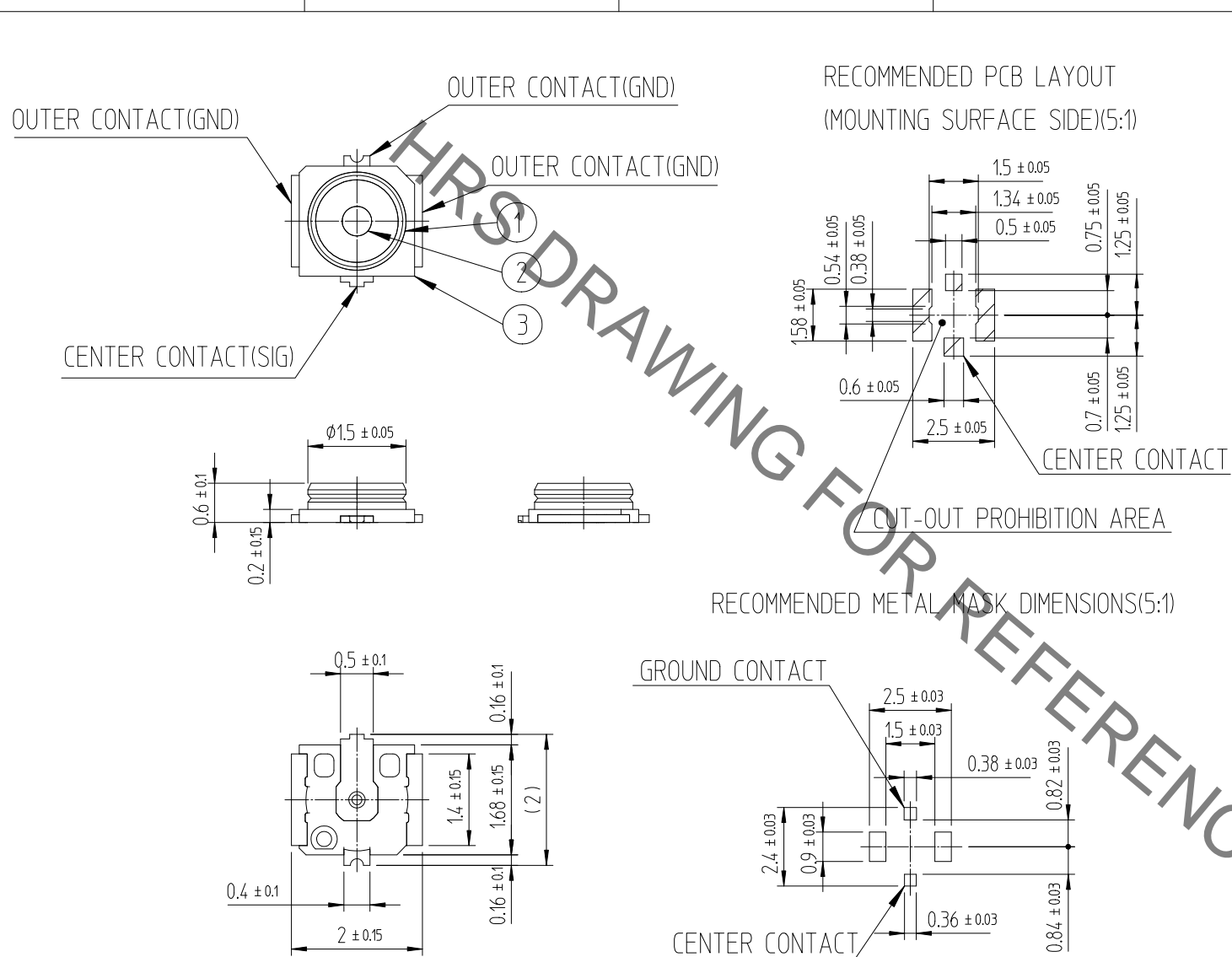

△數 COUNT	訂正事項 DESCRIPTION OF REVISIONS	擔當 B	檢圖 CHKD	年月日 DATE	△數 COUNT	訂正事項 DESCRIPTION OF REVISIONS	擔當 B	檢圖 CHKD	年月日 DATE
△				..	△				..
△				..	△				..
△				..	△				..

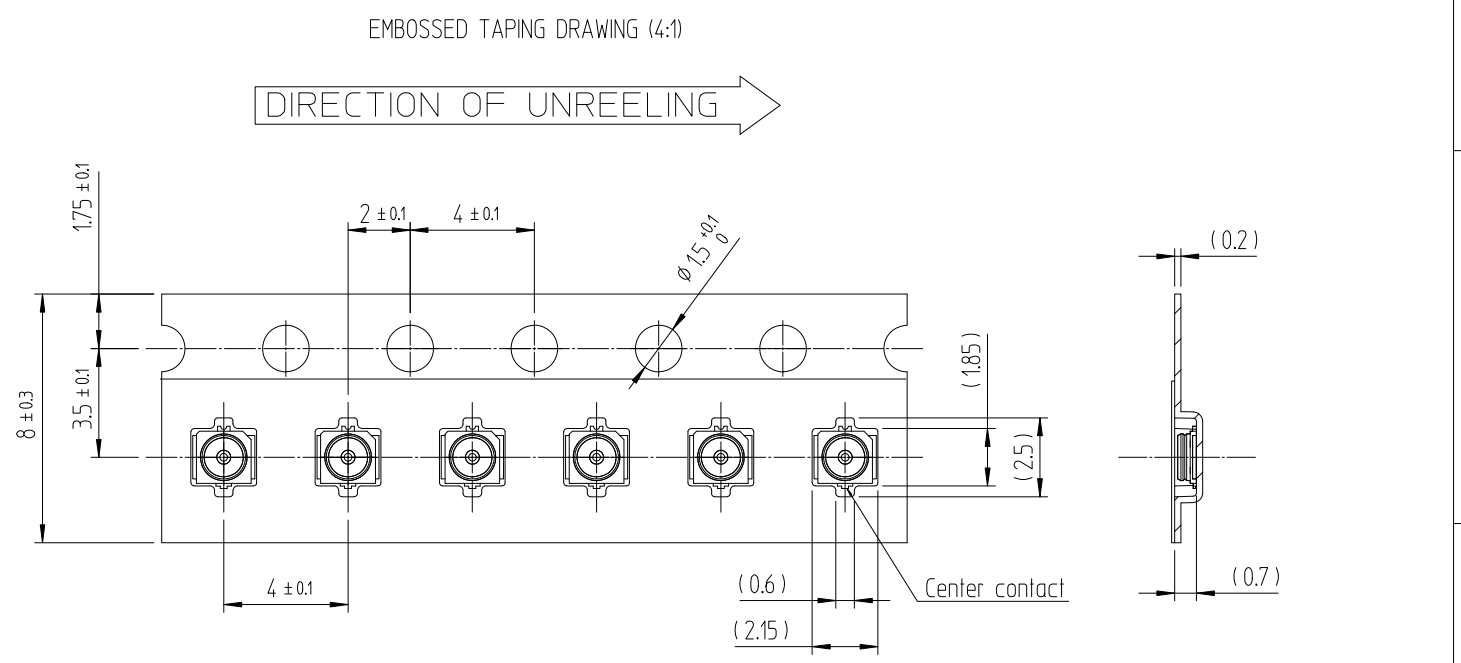

REEL DRAWING(FREE)

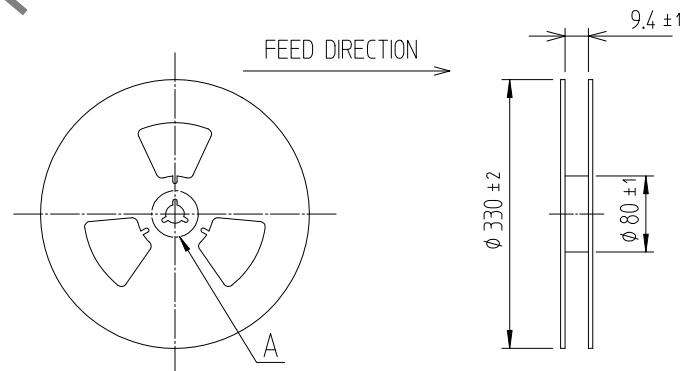

DETAIL 'A'(FREE)

RECOMMENDED REFLOW TEMPERATURE PROFILE

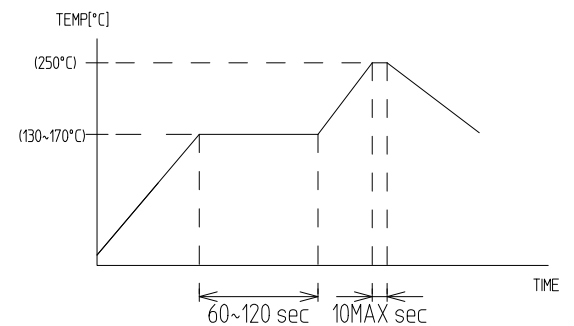

NOTE  
MOUNTING TEMPERATURE PROFILE VARIES ACCORDING  
TO BOARD SIZE, SOLDER TYPE APPLIED AND SOLDER THICKNESS  
- METAL MASK THICKNESS : 0.1mm

RoHS COMPLIANT, Halogen Free

NOTES:

- 1 : THE QUANTITY OF K.FL2-R-SMT-1 IS 10,000 CONNECTORS PER REEL.
- 2 : FOR THE POSSIBILITY OF BREAKAGE OR DEFORMATION DO NOT MATE THIS CONNECTOR WITH PARTNER K.FL2-LP-040 BEFORE MOUNTING ON PC BOARD.
- 3 : USE ALL PRODUCTS WITHIN 6 MONTHS AFTER THE DELIVERY.  
STORE THEM IN MANUFACTURER'S PACKAGE OR TIGHTLY RE-CLOSED BOX WITH THE FOLLOWING CONDECTIONS. CHECK THE TERMINAL SOLDERABILITY BEFORE USE IF THE PRODUCT HAS BEEN STORED FOR MORE THAN 6 MONTHS.  
TEMPERATURE : -10°C TO +40°C  
HUMIDITY : 15 TO 85% RH
- 4 : ENVIRONMENTAL CONDITIONS  
DO NOT USE THE PRODUCTS UNDER THE ENVIRONMENTAL CONDITIONS AS SHOWN BELOW DUE TO POSSIBLE PRODUCT DETERIORATION.  
SPECIAL GAS ATMOSPHERE(HYDROGEN SULFIDE GAS, SULFUR SULFIDE GAS AND HYDROGEN CHLORIDE GAS)  
PLACE ATTENTION REQUIRED:HEATING SYSTEM, AREA NEAR HOT SPRING, VOLCANIC MOUNTAIN AND ALIKE.  
WATER SPLACHED AND CONDENSATION PLACES.  
PLACE ATTENTION REQUIRED:HARSH TEMPERATURE CHANGE.
- 5 : PLEASE CONTACT US IN CASE YOU WILL MAKE DIFFERENT SETTINGS FROM OUR RECOMMENDATION.
- 6 : LEAD CO-PLANARITY SHALL BE 0.1MAX.

1	PHOSPHOR BRONZE	UNDER PLATING : NICKEL OVER PLATING : GOLD	3	LCP	<BLACK>, UL94V-0
			2	BRASS	UNDER PLATING : NICKEL OVER PLATING : GOLD
NO.	MATERIAL	FINISH,REMARKS	NO.	MATERIAL	FINISH,REMARKS
CODE NO. (OLD)			DRAWN	DESIGNED	CHECKED
			W.Y.AHN 19.01.25	W.Y.AHN 19.01.25	H.S.KIM 19.01.25
			APPROVED	RELEASED	
			H.S.KIM 19.01.25	ENG 19.01.25 DEPT	
DRAWING NO. EDC3-632042-80			PART NO. K.FL2-R-SMT-1 (800)		
SCALE 20:1			CODE NO CL6345-0002-1-800		
UNITS mm			1/1		
HRS HIROSE KOREA CO.,LTD.					