

KAD5514P

14-Bit, 250/210/170/125MSPS ADC

The KAD5514P ([KAD5514P-12](#), [KAD5514P-17](#), [KAD5514P-21](#), [KAD5514P-25](#)) is a family of low-power, high performance 14-bit, analog-to-digital converters. The family is designed with the proprietary FemtoCharge™ technology on a standard CMOS process, and supports sampling rates of up to 250MSPS. The KAD5514P is part of a pin-compatible portfolio of 10, 12, and 14-bit ADCs with sample rates ranging from 125MSPS to 500MSPS.

A Serial Peripheral Interface (SPI) port allows for extensive configurability and fine control of various parameters such as gain and offset.

Digital output data is presented in selectable LVDS or CMOS formats. The KAD5514P is available in 72 Ld and 48 Ld QFN packages with an exposed paddle. The devices operate from a 1.8V supply, and performance is specified across the full industrial temperature range (-40°C to +85°C).

Applications

- Power amplifier linearization
- Radar and satellite antenna array processing
- Broadband communications
- High-performance data acquisition
- Communications test equipment
- WiMAX and microwave receivers

Features

- Programmable gain, offset, and skew control
- 950MHz analog input bandwidth
- 60fs clock jitter
- Over-range indicator
- Selectable clock divider: +1, +2, or +4
- Clock phase selection
- Nap and sleep modes
- Two's complement, gray code or binary data format
- DDR LVDS-compatible or LVCMOS outputs
- Programmable built-in test patterns
- Single-supply 1.8V operation
- Pb-free (RoHS compliant)

Key Specifications

- SNR = 69.4dBFS for $f_{IN} = 105\text{MHz}$ (-1dBFS)
- SFDR = 82.2dBc for $f_{IN} = 105\text{MHz}$ (-1dBFS)
- Total power consumption
 - 429/345mW at 250/125MSPS (SDR Mode)
 - 390/309mW at 250/125MSPS (DDR Mode)

Related Literature

For a full list of related documents, visit our website:

- [KAD5514P-12](#), [KAD5514P-17](#), [KAD5514P-21](#), [KAD5514P-25](#) device pages

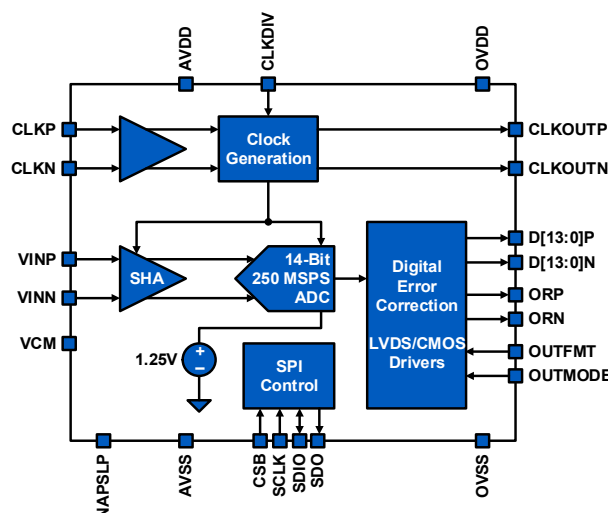

Figure 1. Block Diagram

Contents

1. Overview	4
1.1 Ordering Information	4
1.2 Pin Configurations	5
1.3 Pin Descriptions	6
2. Specifications	10
2.1 Absolute Maximum Ratings	10
2.2 Thermal Information	10
2.3 Electrical Specifications	11
2.4 Digital Specifications	13
2.5 Timing Diagrams	14
2.6 Switching Specifications	14
3. Typical Performance Curves	16
4. Theory of Operation	19
4.1 Functional Description	19
4.2 Power-On Calibration	19
4.3 User-Initiated Reset	20
4.4 Analog Input	21
4.5 Clock Input	22
4.6 Jitter	23
4.7 Voltage Reference	23
4.8 Digital Outputs	23
4.9 Over-Range Indicator	24
4.10 Power Dissipation	24
4.11 Nap/Sleep	24
4.12 Data Format	25
5. Serial Peripheral Interface	27
5.1 SPI Physical Interface	27
5.2 SPI Configuration	29
5.3 Device Information	29
5.4 Indexed Device Configuration/Control	30
5.5 Global Device Configuration/Control	31
5.6 Device Test	33
5.7 SPI Memory Map	34
6. Equivalent Circuits	36
7. Layout Considerations	38
7.1 Split Ground and Power Planes	38
7.2 Clock Input Considerations	38
7.3 Exposed Paddle	38
7.4 Bypass and Filtering	38
7.5 LVDS Outputs	38
7.6 LVCMOS Outputs	38
7.7 Unused Inputs	38
7.8 72 Ld/48 Ld Package Options	38

8.	ADC Evaluation Platform	39
9.	Definitions	40
10.	Revision History	41
11.	Package Outline Drawings	42

1. Overview

1.1 Ordering Information

Part Number (Note 3)	Part Marking	Speed (MSPS)	Temp. Range (°C)	Package (RoHS Compliant)	Pkg. Dwg. #
KAD5514P-25Q72 (Note 1)	KAD5514P-25 Q72EP-I	250	-40 to +85	72 Ld QFN	L72.10X10D
KAD5514P-21Q72 (Note 1)	KAD5514P-21 Q72EP-I	210	-40 to +85	72 Ld QFN	L72.10X10D
KAD5514P-17Q72 (Note 1)	KAD5514P-17 Q72EP-I	170	-40 to +85	72 Ld QFN	L72.10X10D
KAD5514P-12Q72 (Note 1)	KAD5512P-12 Q72EP-I	125	-40 to +85	72 Ld QFN	L72.10X10D
KAD5514P-25Q48 (Note 2)	KAD5512P-25 Q48EP-I	250	-40 to +85	48 Ld QFN	L48.7X7E
KAD5514P-21Q48 (Note 2)	KAD5514P-21 Q48EP-I	210	-40 to +85	48 Ld QFN	L48.7X7E
KAD5514P-17Q48 (Note 2)	KAD5514P-17 Q48EP-I	170	-40 to +85	48 Ld QFN	L48.7X7E
KAD5514P-12Q48 (Note 2)	KAD5514P-12 Q48EP-I	125	-40 to +85	48 Ld QFN	L48.7X7E

Notes:

- These Pb-free plastic packaged products employ special Pb-free material sets; molding compounds/die attach materials and NiPdAu plate-e4 termination finish, which is RoHS compliant and compatible with both SnPb and Pb-free soldering operations. Pb-free products are MSL classified at Pb-free peak reflow temperatures that meet or exceed the Pb-free requirements of IPC/JEDEC J STD-020.
- These Pb-free plastic packaged products employ special Pb-free material sets, molding compounds/die attach materials, and 100% matte tin plate plus anneal (e3 termination finish, which is RoHS compliant and compatible with both SnPb and Pb-free soldering operations). Pb-free products are MSL classified at Pb-free peak reflow temperatures that meet or exceed the Pb-free requirements of IPC/JEDEC J STD-020.
- For Moisture Sensitivity Level (MSL), see the [KAD5514P-12](#), [KAD5514P-17](#), [KAD5514P-21](#), [KAD5514P-25](#) device pages. For more information about MSL, see [TB363](#).

Table 1. Pin-Compatible Family

Model	Resolution (Bits)	Speed (MSPS)
KAD5514P-25	14	250
KAD5514P-21	14	210
KAD5514P-17	14	170
KAD5514P-12	14	125
KAD5512P-50	12	500
KAD5512P-25, KAD5514P-25	12	250
KAD5512P-21, KAD5514P-21	12	210
KAD5512P-17, KAD5514P-17	12	170
KAD5512P-12, KAD5514P-12	12	125
KAD5510P-50	10	500

1.2.2 48 Ld QFN

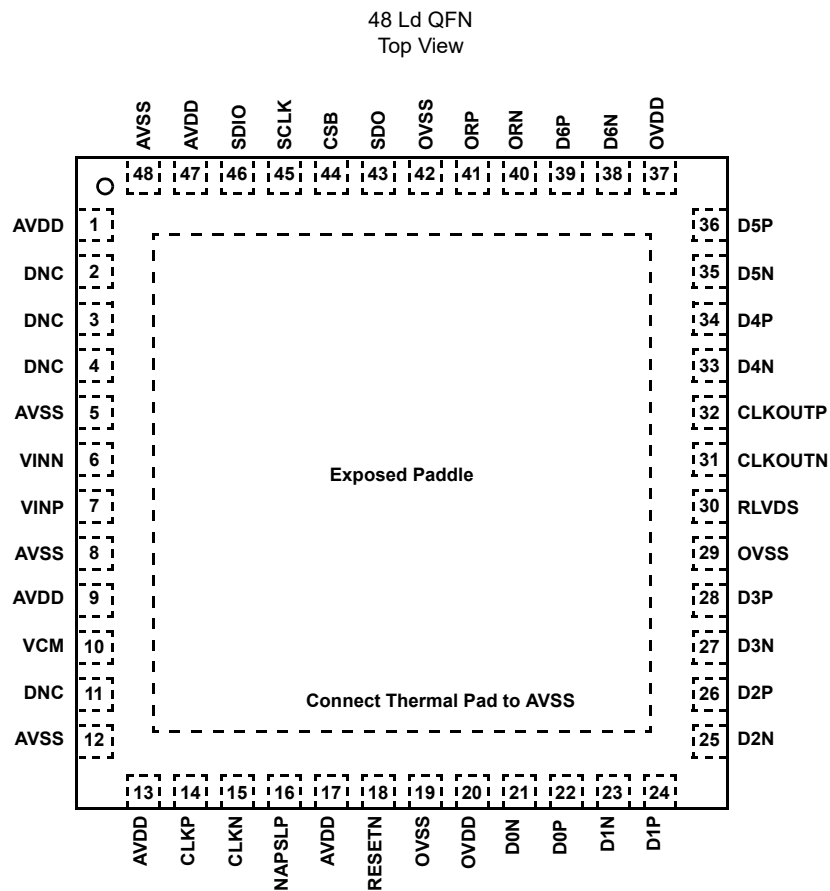

1.3 Pin Descriptions

1.3.1 72 QFN

Pin Number	LVDS [LVCMOS] Name	LVDS [LVCMOS] Function SDR Mode	DDR Mode Comments
1, 6, 12, 19, 24, 71	AVDD	1.8V Analog Supply	
2, 3, 4, 5, 13, 14, 17, 18	DNC	Do Not Connect	
7, 8, 11, 72	AVSS	Analog Ground	
9	VINN	Analog Input Negative	
10	VINP	Analog Input Positive	
15	VCM	Common-Mode Output	
16	CLKDIV	Tri-Level Clock Divider Control	
20, 21	CLKP, CLKN	Clock Input True, Complement	
22	OUTMODE	Tri-Level Output Mode (LVDS, LVCMOS)	
23	NAPSLP	Tri-Level Power Control (Nap, Sleep modes)	
25	RESETN	Power-On Reset (Active Low, see "User-Initiated Reset" on page 20)	
26, 45, 55, 65	OVSS	Output Ground	
27, 36, 56	OVDD	1.8V Output Supply	

Pin Number	LVDS [LVCMOS] Name	LVDS [LVCMOS] Function SDR Mode	DDR Mode Comments
28	D0N [NC]	LVDS Bit 0 (LSB) Output Complement [NC in LVCMOS]	DDR Logical Bits 1, 0 (LVDS)
29	D0P [D0]	LVDS Bit 0 (LSB) Output True [LVCMOS Bit 0]	DDR Logical Bits 1, 0 (LVDS or CMOS)
30	D1N [NC]	LVDS Bit 1 Output Complement [NC in LVCMOS]	NC in DDR
31	D1P [D1]	LVDS Bit 1 Output True [LVCMOS Bit 1]	NC in DDR
32	D2N [NC]	LVDS Bit 2 Output Complement [NC in LVCMOS]	DDR Logical Bits 3, 2 (LVDS)
33	D2P [D2]	LVDS Bit 2 Output True [LVCMOS Bit 2]	DDR Logical Bits 3, 2 (LVDS or CMOS)
34	D3N [NC]	LVDS Bit 3 Output Complement [NC in LVCMOS]	NC in DDR
35	D3P [D3]	LVDS Bit 3 Output True [LVCMOS Bit 3]	NC in DDR
37	D4N [NC]	LVDS Bit 4 Output Complement [NC in LVCMOS]	DDR Logical Bits 5, 4 (LVDS)
38	D4P [D4]	LVDS Bit 4 Output True [LVCMOS Bit 4]	DDR Logical Bits 5, 4 (LVDS or CMOS)
39	D5N [NC]	LVDS Bit 5 Output Complement [NC in LVCMOS]	NC in DDR
40	D5P [D5]	LVDS Bit 5 Output True [LVCMOS Bit 5]	NC in DDR
41	D6N [NC]	LVDS Bit 6 Output Complement [NC in LVCMOS]	DDR Logical Bits 7, 6 (LVDS)
42	D6P [D6]	LVDS Bit 6 Output True [LVCMOS Bit 6]	DDR Logical Bits 7, 6 (LVDS or CMOS)
43	D7N [NC]	LVDS Bit 7 Output Complement [NC in LVCMOS]	NC in DDR
44	D7P [D7]	LVDS Bit 7 Output True [LVCMOS Bit 7]	NC in DDR
46	RLVDS	LVDS Bias Resistor	
47	CLKOUTN [NC]	LVDS Clock Output Complement [NC in LVCMOS]	
48	CLKOUTP [CLKOUT]	LVDS Clock Output True [LVCMOS CLKOUT]	
49	D8N [NC]	LVDS Bit 8 Output Complement [NC in LVCMOS]	DDR Logical Bits 9, 8 (LVDS)
50	D8P [D8]	LVDS Bit 8 Output True [LVCMOS Bit 8]	DDR Logical Bits 9, 8 (LVDS or CMOS)
51	D9N [NC]	LVDS Bit 9 Output Complement [NC in LVCMOS]	NC in DDR
52	D9P [D9]	LVDS Bit 9 Output True [LVCMOS Bit 9]	NC in DDR
53	D10N [NC]	LVDS Bit 10 Output Complement [NC in LVCMOS]	DDR Logical Bits 11, 10 (LVDS)
54	D10P [D10]	LVDS Bit 10 Output True [LVCMOS Bit 10]	DDR Logical Bits 11, 10 (LVDS or CMOS)
57	D11N [NC]	LVDS Bit 11 Output Complement [NC in LVCMOS]	NC in DDR

Pin Number	LVDS [LVCMOS] Name	LVDS [LVCMOS] Function SDR Mode	DDR Mode Comments
58	D11P [D11]	LVDS Bit 11 Output True [LVCMOS Bit 11]	NC in DDR
59	D12N [NC]	LVDS Bit 12 Output Complement [NC in LVCMOS]	DDR Logical Bits 13, 12 (LVDS)
60	D12P [D10]	LVDS Bit 12 Output True [LVCMOS Bit 10]	DDR Logical Bits 13, 12 (LVDS or CMOS)
61	D13N [NC]	LVDS Bit 13 (MSB) Output Complement [NC in LVCMOS]	NC in DDR
62	D13P [D13]	LVDS Bit 13 (MSB) Output True [LVCMOS Bit 11]	NC in DDR
63	ORN [NC]	LVDS Over-Range Complement [NC in LVCMOS]	
64	ORP [OR]	LVDS Over-Range True [LVCMOS Over-Range]	
66	SDO	SPI Serial Data Output (4.7kΩ pull-up to OVDD is required)	
67	CSB	SPI Chip Select (active low)	
68	SCLK	SPI Clock	
69	SDIO	SPI Serial Data Input/Output	
70	OUTFMT	Tri-Level Output Data Format (Two's Complement, Gray Code, Offset Binary)	
Exposed Paddle	AVSS	Analog Ground	

Note: LVCMOS Output Mode Functionality is shown in brackets (NC = No Connection).

1.3.2 48 QFN

Pin Number	LVDS [LVCMOS] Name	LVDS [LVCMOS] Function
1, 9, 13, 17, 47	AVDD	1.8V Analog Supply
2, 3, 4, 11	DNC	Do Not Connect
5, 8, 12, 48	AVSS	Analog Ground
6	VINN	Analog Input Negative
7	VINP	Analog Input Positive
10	VCM	Common Mode Output
14, 15	CLKP, CLKN	Clock Input True, Complement
16	NAPSLP	Tri-Level Power Control (Nap, Sleep Modes)
18	RESETN	Power-on Reset (Active Low, see "User-Initiated Reset" on page 20)
19, 29, 42	OVSS	Output Ground
20, 37	OVDD	1.8V Output Supply
21	D0N [NC]	LVDS DDR Logical Bits 1, 0 Output Complement [NC in LVCMOS]
22	D0P [D0]	LVDS DDR Logical Bits 1, 0 Output True [CMOS DDR Logical Bits 1, 0 in LVCMOS]
23	D1N [NC]	LVDS DDR Logical Bits 3, 2 Output Complement [NC in LVCMOS]
24	D1P [D1]	LVDS DDR Logical Bits 3, 2 Output True [CMOS DDR Logical Bits 3, 2 in LVCMOS]
25	D2N [NC]	LVDS DDR Logical Bits 5, 4 Output Complement [NC in LVCMOS]

Pin Number	LVDS [LVCMOS] Name	LVDS [LVCMOS] Function
26	D2P [D2]	LVDS DDR Logical Bits 5, 4 Output True [CMOS DDR Logical Bits 5, 4 in LVCMOS]
27	D3N [NC]	LVDS DDR Logical Bits 7, 6 Output Complement [NC in LVCMOS]
28	D3P [D3]	LVDS DDR Logical Bits 7, 6 Output True [CMOS DDR Logical Bits 7, 6 in LVCMOS]
30	RLVDS	LVDS Bias Resistor
31	CLKOUTN [NC]	LVDS Clock Output Complement [NC in LVCMOS]
32	CLKOUTP [CLKOUT]	LVDS Clock Output True [LVCMOS CLKOUT]
33	D4N [NC]	LVDS DDR Logical Bits 9, 8 Output Complement [NC in LVCMOS]
34	D4P [D4]	LVDS DDR Logical Bits 9, 8 Output True [CMOS DDR Logical Bits 9, 8 in LVCMOS]
35	D5N [NC]	LVDS DDR Logical Bits 11, 10 Output Complement [NC in LVCMOS]
36	D5P [D5]	LVDS DDR Logical Bits 11, 10 Output True [CMOS DDR Logical Bits 11, 10 in LVCMOS]
38	D6N [NC]	LVDS DDR Logical Bits 13, 12 Output Complement [NC in LVCMOS]
39	D6P [D6]	LVDS DDR Logical Bits 13, 12 Output True [CMOS DDR Logical Bits 13, 12 in LVCMOS]
40	ORN [NC]	LVDS Over-Range Complement [NC in LVCMOS]
41	ORP [OR]	LVDS Over-Range True [LVCMOS Over-Range]
43	SDO	SPI Serial Data Output (4.7kΩ pull-up to OVDD is required)
44	CSB	SPI Chip Select (active low)
45	SCLK	SPI Clock
46	SDIO	SPI Serial Data Input/Output
Exposed Paddle	AVSS	Analog Ground

Note: LVCMOS output mode functionality is shown in brackets (NC = No Connection).

2. Specifications

2.1 Absolute Maximum Ratings

Parameter	Minimum	Maximum	Unit
AVDD to AVSS	-0.4	2.1	V
OVDD to OVSS	-0.4	2.1	V
AVSS to OVSS	-0.3	0.3	V
Analog Inputs to AVSS	-0.4	AVDD + 0.3	V
Clock Inputs to AVSS	-0.4	AVDD + 0.3	V
Logic Inputs to AVSS	-0.4	OVDD + 0.3	V
Logic Inputs to OVSS	-0.4	OVDD + 0.3	V

CAUTION: Do not operate at or near the maximum ratings listed for extended periods of time. Exposure to such conditions can adversely impact product reliability and result in failures not covered by warranty.

2.2 Thermal Information

Thermal Resistance (Typical, Note 4)	θ_{JA} (°C/W)
48 Ld QFN Package	25
72 Ld QFN Package	24

Notes:

4. θ_{JA} is measured with the component mounted on a high effective thermal conductivity test board in free air. See [TB379](#) for details.

Parameter	Minimum	Maximum	Unit
Operating Temperature	-40	+85	°C
Storage Temperature	-65	+150	°C
Junction Temperature		+150	°C
Pb-Free Reflow Profile	see TB493		

2.3 Electrical Specifications

All specifications apply under the following conditions unless otherwise noted: AVDD = 1.8V, OVDD = 1.8V, T_A = -40°C to +85°C (typical specifications at +25°C), A_{IN} = -1dBFS, f_{SAMPLE} = maximum conversion rate (per speed grade).

Parameter	Symbol	Test Conditions	KAD5514P-25 (Note 8)			KAD5514P-21 (Note 8)			KAD5514P-17 (Note 8)			KAD5514P-12 (Note 8)			Unit
			Min	Typ	Max	Min	Typ	Max	Min	Typ	Max	Min	Typ	Max	
DC Specifications															
Analog Input															
Full-Scale Analog Input Range	V _{FS}	Differential	1.4	1.47	1.54	1.4	1.47	1.54	1.4	1.47	1.54	1.4	1.47	1.54	V _{P-P}
Input Resistance	R _{IN}	Differential		500			500			500			500		Ω
Input Capacitance	C _{IN}	Differential		2.6			2.6			2.6			2.6		pF
Full-Scale Range Temperature Drift	A _{VTC}	Full Temperature		90			90			90			90		ppm/°C
Input Offset Voltage	V _{OS}		-10	±2	10	-10	±2	10	-10	±2	10	-10	±2	10	mV
Gain Error	E _G			±0.6			±0.6			±0.6			±0.6		%
Common-Mode Output Voltage	V _{CM}		435	535	635	435	535	635	435	535	635	435	535	635	mV
Clock Inputs															
Inputs Common-Mode Voltage				0.9			0.9			0.9			0.9		V
CLKP, CLKN Input Swing				1.8			1.8			1.8			1.8		V
Power Requirements															
1.8V Analog Supply Voltage	AVDD		1.7	1.8	1.9	1.7	1.8	1.9	1.7	1.8	1.9	1.7	1.8	1.9	V
1.8V Digital Supply Voltage	OVDD		1.7	1.8	1.9	1.7	1.8	1.9	1.7	1.8	1.9	1.7	1.8	1.9	V
1.8V Analog Supply Current	I _{AVDD}			170	190		157	176		145	163		129	147	mA
1.8V Digital Supply Current (Note 5) (SDR)	I _{OVDD}	3mA LVDS		68	76		66	74		64	72		62	70	mA
1.8V Digital Supply Current (Note 5) (DDR)	I _{OVDD}	3mA LVDS		46			44			43			42		mA
Power Supply Rejection Ratio	PSRR	30MHz, 200mV _{P-P} signal on AVDD		-36			-36			-36			-36		dB

All specifications apply under the following conditions unless otherwise noted: AVDD = 1.8V, OVDD = 1.8V, T_A = -40°C to +85°C (typical specifications at +25°C), A_{IN} = -1dBFS, f_{SAMPLE} = maximum conversion rate (per speed grade). (Continued)

Parameter	Symbol	Test Conditions	KAD5514P-25 (Note 8)			KAD5514P-21 (Note 8)			KAD5514P-17 (Note 8)			KAD5514P-12 (Note 8)			Unit
			Min	Typ	Max	Min	Typ	Max	Min	Typ	Max	Min	Typ	Max	
Total Power Dissipation															
Normal Mode (SDR)	P _D	3mA LVDS		429	463		402	433		378	406		345	376	mW
Normal Mode (DDR)	P _D	3mA LVDS		390			363			339			309		mW
Nap Mode	P _D			148	170.2		142	164.2		136	158.2		129	150.2	mW
Sleep Mode	P _D	CSB at logic high		2	6		2	6		2	6		2	6	mW
Nap Mode Wake-Up Time (Note 6)		Sample Clock Running		1			1			1			1		μs
Sleep Mode Wake-Up Time (Note 6)		Sample Clock Running		1			1			1			1		ms
AC Specifications															
Differential Nonlinearity	DNL		-1.0	±0.3	1.0	-1.0	±0.3	1.0	-1.0	±0.3	1.0	-1.0	±0.3	1.0	LSB
Integral Nonlinearity	INL			±3.5			±3.5			±3.5			±5.0		LSB
Minimum Conversion Rate (Note 7)	f _S MIN				40			40			40			40	MSPS
Maximum Conversion Rate	f _S MAX		250			210			170			125			MSPS
Signal-to-Noise Ratio	SNR	f _{IN} = 10MHz		69.5		70.2			70.6			70.9			dBFS
		f _{IN} = 105MHz	66.4	69.4		67.4	70.2		68.1	70.4		68.4	70.7		dBFS
		f _{IN} = 190MHz		68.9			69.4			70.0			70.1		dBFS
		f _{IN} = 364MHz		67.6			68.1			68.9			68.7		dBFS
		f _{IN} = 695MHz		64.9			65.1			66.3			65.7		dBFS
		f _{IN} = 995MHz		62.6			62.9			64.1			63.4		dBFS
Signal-to-Noise and Distortion	SINAD	f _{IN} = 10MHz		69.4		70.2			70.5			70.7			dBFS
		f _{IN} = 105MHz	65.9	69.1		66.9	70.2		67.6	70.1		67.6	70.3		dBFS
		f _{IN} = 190MHz		68.4			69.1			69.4			69.7		dBFS
		f _{IN} = 364MHz		66.7			67.0			67.6			67.6		dBFS
		f _{IN} = 695MHz		59.0			58.9			60.1			59.9		dBFS
		f _{IN} = 995MHz		48.2			48.2			49.1			50.4		dBFS
Effective Number of Bits	ENOB	f _{IN} = 10MHz		11.2		11.4			11.4			11.5			Bits
		f _{IN} = 105MHz	10.8	11.2		10.9	11.4		11.0	11.4		11.0	11.4		Bits
		f _{IN} = 190MHz		11.1			11.2			11.2			11.3		Bits
		f _{IN} = 364MHz		10.8			10.8			10.9			10.9		Bits
		f _{IN} = 695MHz		9.5			9.5			9.7			9.7		Bits
		f _{IN} = 995MHz		7.7			7.7			7.9			8.1		Bits

All specifications apply under the following conditions unless otherwise noted: AVDD = 1.8V, OVDD = 1.8V, T_A = -40°C to +85°C (typical specifications at +25°C), A_{IN} = -1dBFS, f_{SAMPLE} = maximum conversion rate (per speed grade). (Continued)

Parameter	Symbol	Test Conditions	KAD5514P-25 (Note 8)			KAD5514P-21 (Note 8)			KAD5514P-17 (Note 8)			KAD5514P-12 (Note 8)			Unit
			Min	Typ	Max	Min	Typ	Max	Min	Typ	Max	Min	Typ	Max	
Spurious-Free Dynamic Range	SFDR	f _{IN} = 10MHz		89.9			86.7			87.2			84.9		dBc
		f _{IN} = 105MHz	70.0	82.2		70.0	85.2		70.0	82.0		70.0	81.7		dBc
		f _{IN} = 190MHz		80.2			79.6			79.2			80.2		dBc
		f _{IN} = 364MHz		75.5			75.6			75.1			75.5		dBc
		f _{IN} = 695MHz		60.4			60.7			61.3			61.4		dBc
		f _{IN} = 995MHz		47.9			48.5			48.7			50.1		dBc
Intermodulation Distortion	IMD	f _{IN} = 70MHz		-89.2			-92.3			-94.5			-94.9		dBFS
		f _{IN} = 170MHz		-91.4			-86.9			-91.7			-85.7		dBFS
Word Error Rate	WER			10 ⁻¹²			10 ⁻¹²			10 ⁻¹²			10 ⁻¹²		
Full Power Bandwidth	FPBW			950			950			950			950		MHz

Notes:

- Digital Supply Current is dependent upon the capacitive loading of the digital outputs. I_{OVDD} specifications apply for 10pF load on each digital output.
- See ["Nap/Sleep" on page 24](#) for more detail.
- The DLL Range setting must be changed for low speed operation. See the ["Serial Peripheral Interface" on page 27](#) for more detail.
- Parameters with MIN and/or MAX limits are 100% production tested at their worst case temperature extreme (+85°C).

2.4 Digital Specifications

Parameter	Symbol	Test Conditions	Min	Typ	Max	Unit
Inputs						
Input Current High (SDIO, RESETN)	I _{IH}	V _{IN} = 1.8V	0	1	10	μA
Input Current Low (SDIO, RESETN)	I _{IL}	V _{IN} = 0V	-25	-12	-5	μA
Input Voltage High (SDIO, RESETN)	V _{IH}		1.17			V
Input Voltage Low (SDIO, RESETN)	V _{IL}				.63	V
Input Current High (OUTMODE, NAPSLP, CLKDIV, OUTFMT) (Note 9)	I _{IH}		15	25	40	μA
Input Current Low (OUTMODE, NAPSLP, CLKDIV, OUTFMT)	I _{IL}		-40	25	-15	μA
Input Capacitance	C _{DI}			3		pF
LVDS Outputs						
Differential Output Voltage	V _T	3mA Mode		620		mV _{P-P}
Output Offset Voltage	V _{OS}	3mA Mode	950	965	980	mV
Output Rise Time	t _R			500		ps
Output Fall Time	t _F			500		ps
CMOS Outputs						
Voltage Output High	V _{OH}	I _{OH} = -500μA	OVDD - 0.3	OVDD - 0.1		V
Voltage Output Low	V _{OL}	I _{OL} = 1mA		0.1	0.3	V
Output Rise Time	t _R			1.8		ns
Output Fall Time	t _F			1.4		ns

2.5 Timing Diagrams

2.5.1 LVDS Timing Diagrams

See [“Digital Outputs” on page 23.](#)

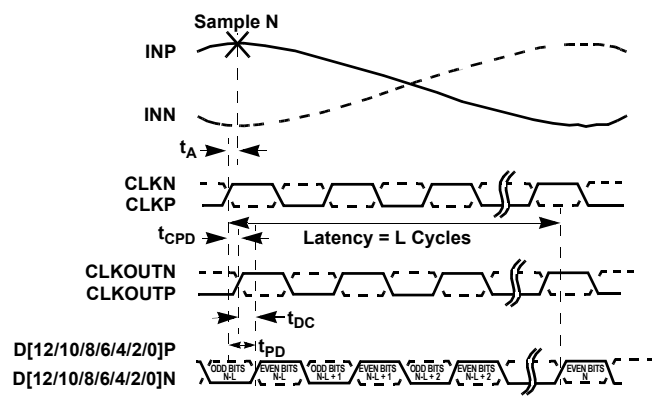

Figure 2. DDR

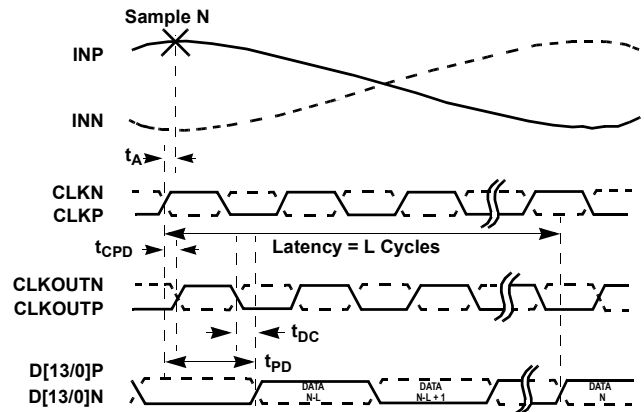

Figure 3. SDR

2.5.2 CMOS Timing Diagram

See [“Digital Outputs” on page 23.](#)

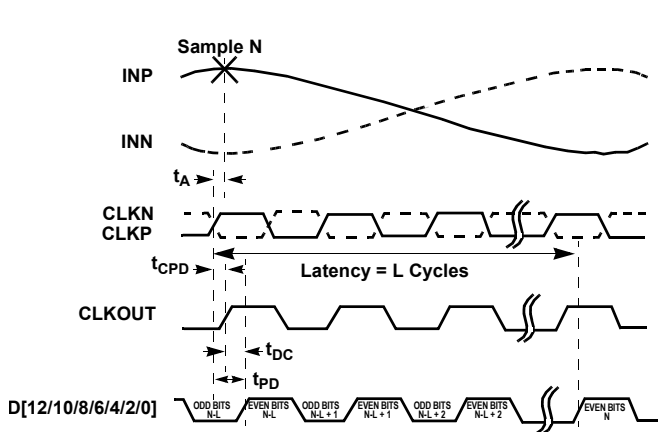

Figure 4. DDR

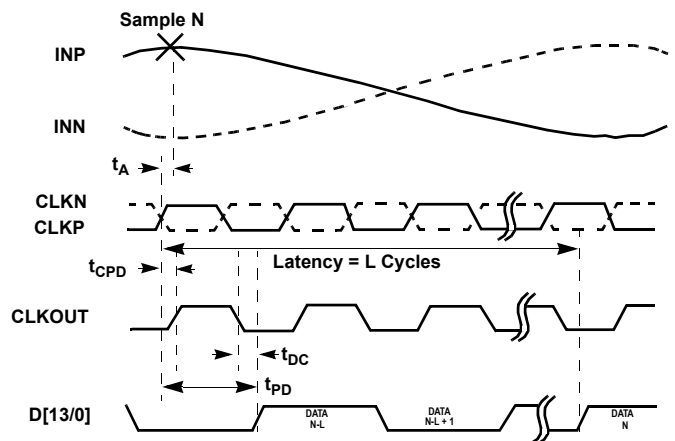

Figure 5. SDR

2.6 Switching Specifications

Parameter	Condition	Symbol	Min	Typ	Max	Units
ADC Output						
Aperture Delay		t_A		375		ps
RMS Aperture Jitter		j_A		60		fs
Output Clock to Data Propagation Delay, LVDS Mode (Note 10)	DDR, Rising Edge	t_{DC}	-260	-50	120	ps
	DDR, Falling Edge	t_{DC}	-160	10	230	ps
	SDR, Falling Edge	t_{DC}	-260	-40	230	ps
Output Clock to Data Propagation Delay, CMOS Mode (Note 10)	DDR, Rising Edge	t_{DC}	-220	-10	200	ps
	DDR, Falling Edge	t_{DC}	-310	-90	110	ps
	SDR, Falling Edge	t_{DC}	-310	-50	200	ps
Latency (Pipeline Delay)		L		8.5		cycles

Parameter	Condition	Symbol	Min	Typ	Max	Units
Overvoltage Recovery		t_{OVR}		1		cycles
SPI Interface (Notes 11, 12)						
SCLK Period	Write Operation	t_{CLK}	16			cycles (Note 11)
	Read Operation	t_{CLK}	66			cycles
SCLK Duty Cycle (t_{HI}/t_{CLK} or t_{LO}/t_{CLK})	Read or Write		25	50	75	%
CSB \downarrow to SCLK \uparrow Set-Up Time	Read or Write	t_S	1			cycles
CSB \uparrow after SCLK \uparrow Hold Time	Read or Write	t_H	3			cycles
Data Valid to SCLK \uparrow Set-Up Time	Write	t_{DSW}	1			cycles
Data Valid after SCLK \uparrow Hold Time	Write	t_{DHW}	3			cycles
Data Valid after SCLK \downarrow Time	Read	t_{DVR}			16.5	cycles
Data Invalid after SCLK \uparrow Time	Read	t_{DHR}	3			cycles
Sleep Mode CSB \downarrow to SCLK \uparrow Set-Up Time (Note 13)	Read or Write in Sleep Mode	t_S	150			μ s

Notes:

9. The Tri-Level Inputs internal switching thresholds are approximately 0.43V and 1.34V. It is advised to float the inputs, tie to ground, or tie to AVDD depending on the function.
10. The input clock to output clock delay is a function of sample rate; using the output clock to latch the data simplifies data capture for most applications. Contact [support](#) for more info if needed.
11. SPI Interface timing is directly proportional to the ADC sample period (4ns at 250MSPS).
12. The SPI may operate asynchronously with respect to the ADC sample clock.
13. The CSB set-up time increases in sleep mode due to the reduced power state. CSB set-up time in Nap mode is equal to normal mode CSB set-up time (4ns min).

3. Typical Performance Curves

All typical performance characteristics apply under the following conditions unless otherwise noted: AVDD = OVDD = 1.8V, T_A = +25°C, A_{IN} = -1dBFS, f_{IN} = 105MHz, f_{SAMPLE} = Maximum Conversion Rate (per speed grade).

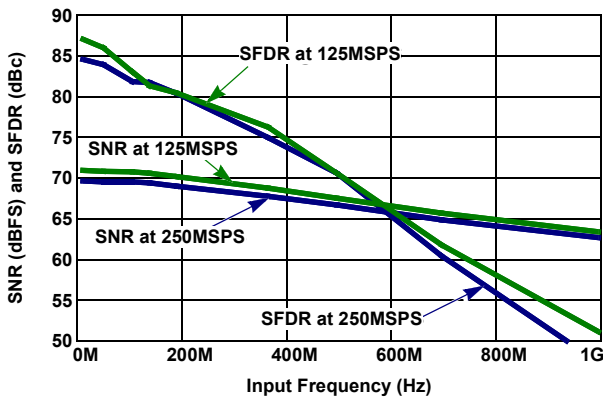

Figure 6. SNR and SFDR vs f_{IN}

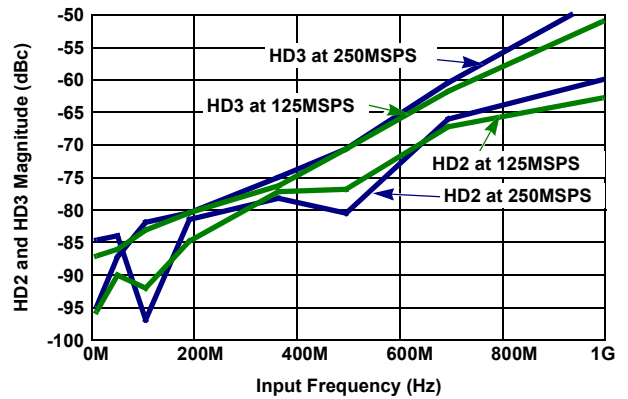

Figure 7. HD2 and HD3 vs f_{IN}

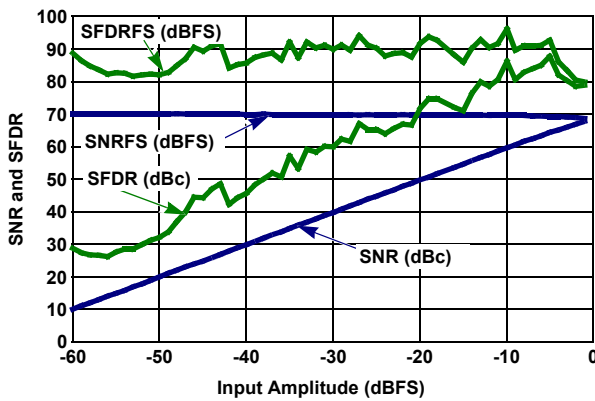

Figure 8. SNR and SFDR vs A_{IN}

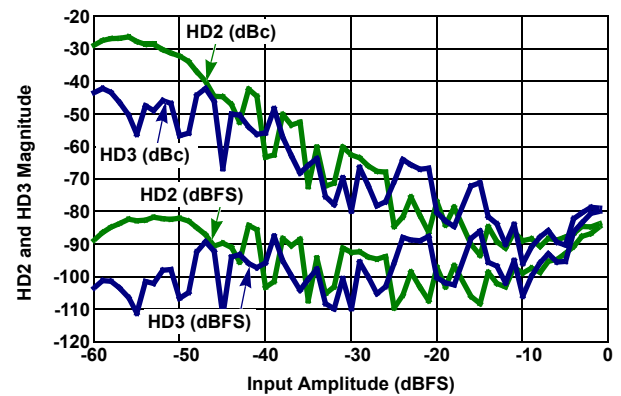

Figure 9. HD2 and HD3 vs A_{IN}

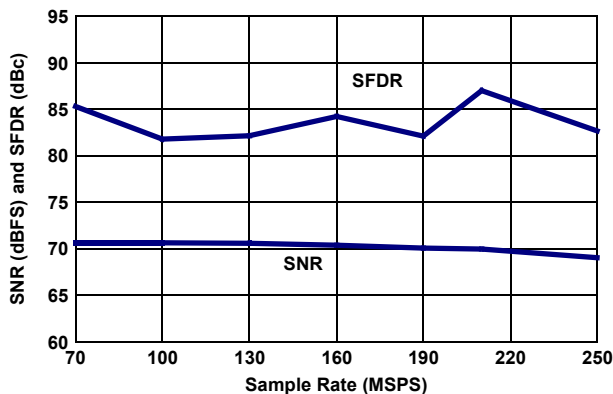

Figure 10. SNR and SFDR vs f_{SAMPLE}

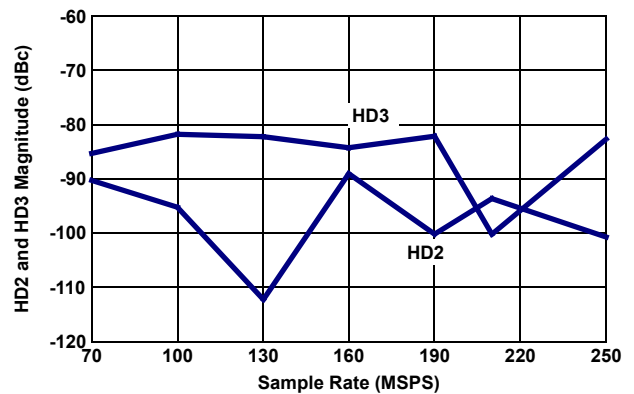

Figure 11. HD2 and HD3 vs f_{SAMPLE}

All typical performance characteristics apply under the following conditions unless otherwise noted: AVDD = OVDD = 1.8V, T_A = +25°C, A_{IN} = -1dBFS, f_{IN} = 105MHz, f_{SAMPLE} = Maximum Conversion Rate (per speed grade). **(Continued)**

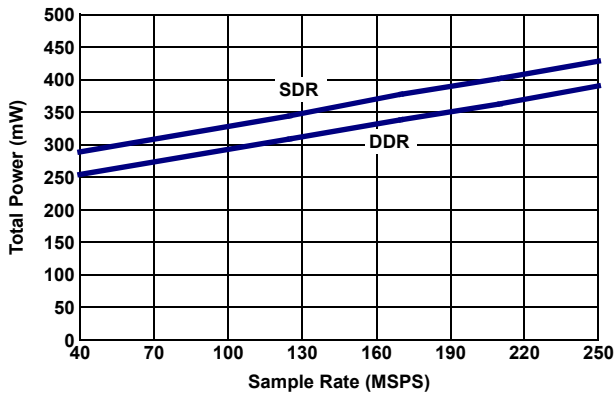

Figure 12. Power vs f_{SAMPLE} in 3mA LVDS Mode

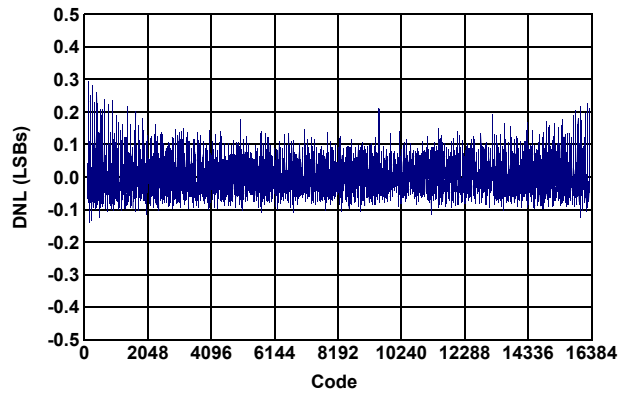

Figure 13. Differential Nonlinearity

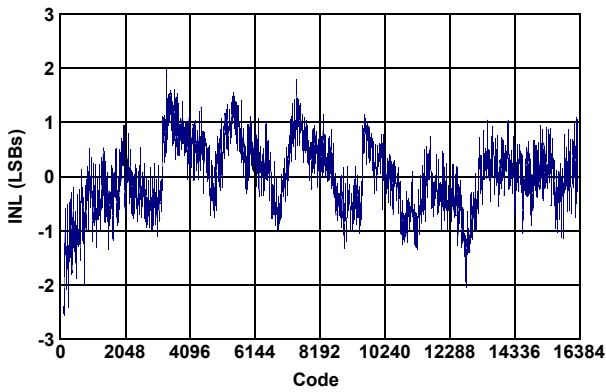

Figure 14. Integral Nonlinearity

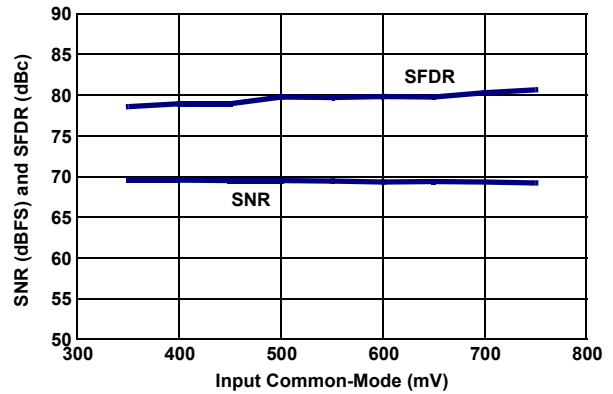

Figure 15. SNR and SFDR vs VCM

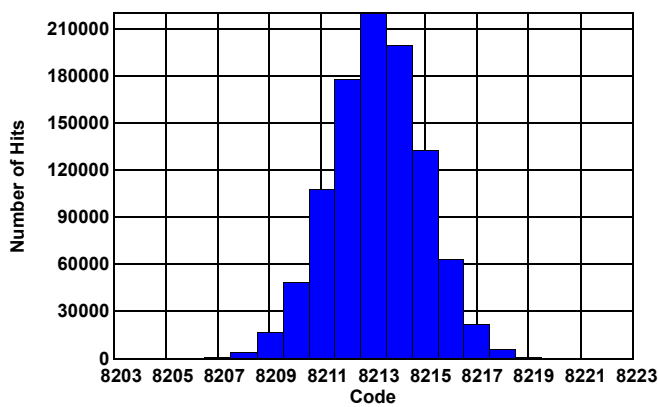

Figure 16. Noise Histogram

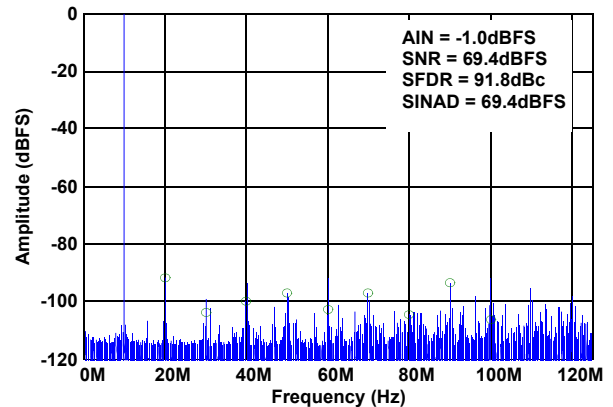

Figure 17. Single-Tone Spectrum AT 10MHz

All typical performance characteristics apply under the following conditions unless otherwise noted: AVDD = OVDD = 1.8V, T_A = +25°C, A_{IN} = -1dBFS, f_{IN} = 105MHz, f_{SAMPLE} = Maximum Conversion Rate (per speed grade). **(Continued)**

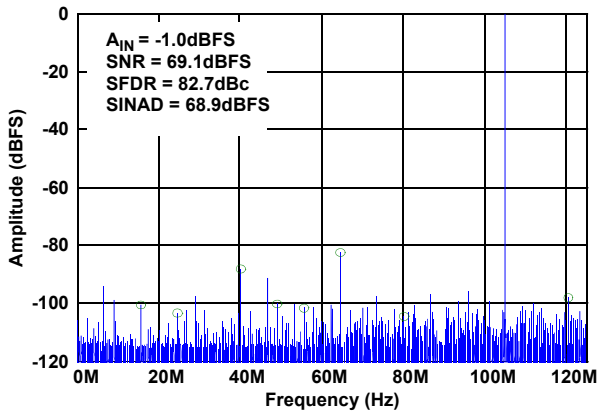

Figure 18. Single-Tone Spectrum at 105MHz

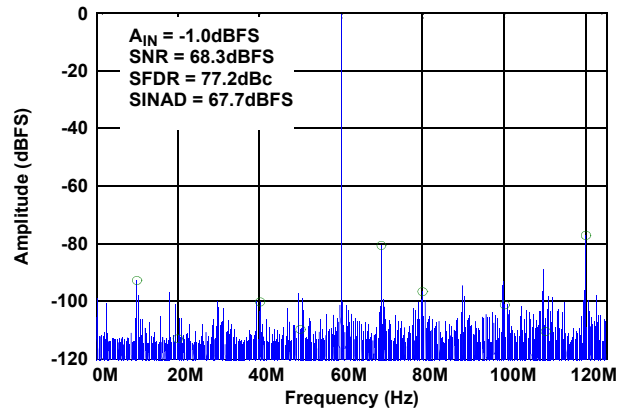

Figure 19. Single-Tone Spectrum at 190MHz

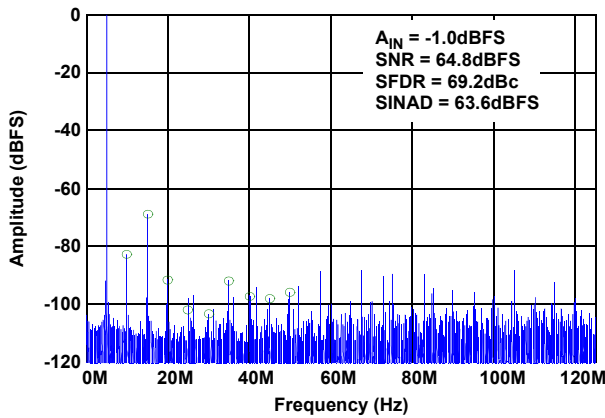

Figure 20. Single-Tone Spectrum at 495MHz

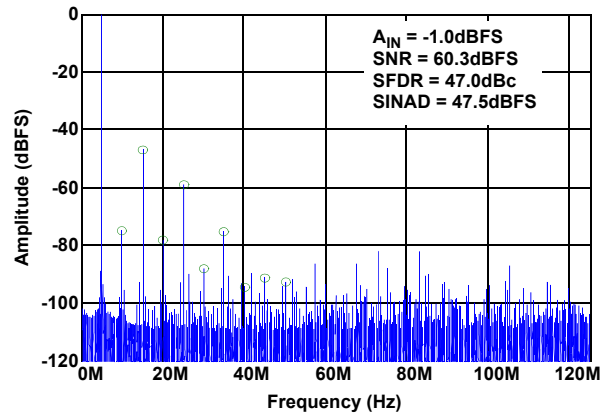

Figure 21. Single-Tone Spectrum at 995MHz

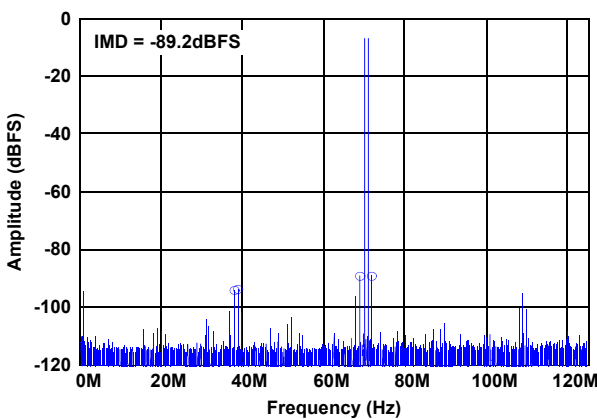

Figure 22. Two-Tone Spectrum at 70MHz

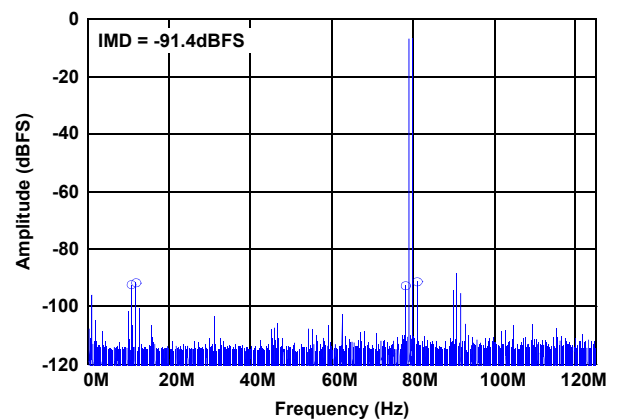

Figure 23. Two-Tone Spectrum at 170MHz

4. Theory of Operation

4.1 Functional Description

The KAD5514P is based upon a 12-bit, 250MSPS ADC core that uses a pipelined successive approximation architecture (Figure 24). The input voltage is captured by a Sample-Hold Amplifier (SHA) and converted to a unit of charge. Proprietary charge-domain techniques successively compare the input to a series of reference charges. Decisions made during the successive approximation operations determine the digital code for each input value. The converter pipeline requires six samples to produce a result. Digital error correction is also applied, and results in a total latency of seven and one half clock cycles. This is evidenced by a time lag on the digital outputs between the start of a conversion and the data is available on the digital outputs.

The KAD5514P family operates by simultaneously sampling the input signal with two ADC cores in parallel and summing the digital result. SNR increases because the input signal is correlated between the two cores and noise is not. As a result of this architecture, indexed SPI operations must be executed on each core in series. See [“Indexed Device Configuration/Control” on page 30](#) for more details.

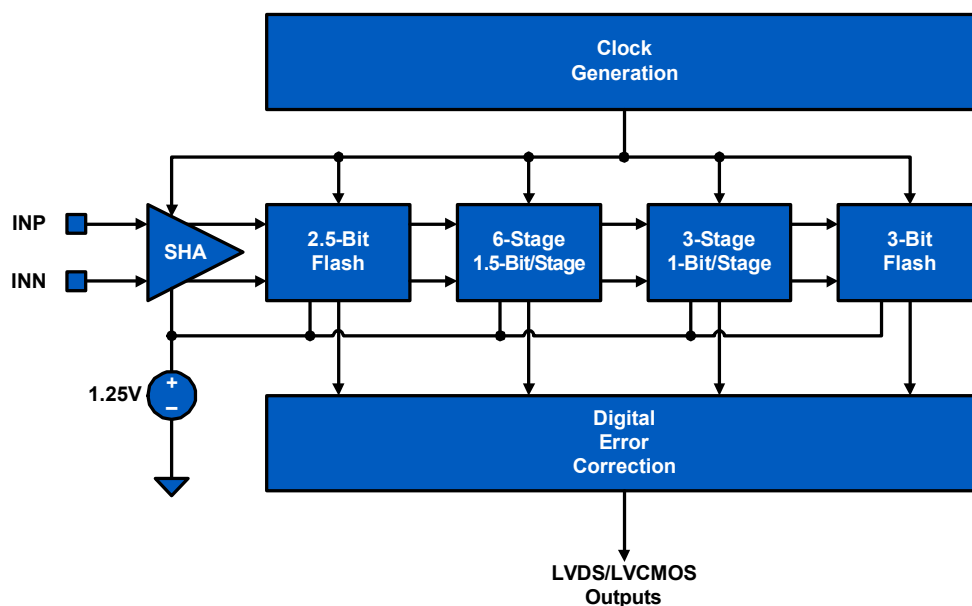

Figure 24. ADC Core Block Diagram

4.2 Power-On Calibration

The ADC performs a self-calibration at start-up. An internal Power-On Reset (POR) circuit detects the supply voltage ramps and initiates the calibration when the analog and digital supply voltages are above a threshold. The following conditions must be adhered to for the power-on calibration to execute successfully:

- A frequency-stable conversion clock must be applied to the CLKP/CLKN pins.
- DNC pins (especially 3, 4, and 18) must not be pulled up or down.
- SDO (pin 66) must be high.
- RESETN (pin 25) must begin low.
- SPI communications must not be attempted.

A user-initiated reset can subsequently be invoked if the above conditions cannot be met at power-up.

The SDO pin requires an external 4.7kΩ pull-up to OVDD. If the SDO pin is pulled low externally during power-up, calibration is not executed properly.

After the power supply has stabilized, the internal POR releases RESETN and an internal pull-up pulls it high, which starts the calibration sequence. If a subsequent user-initiated reset is required, connect the RESETN pin to an open-drain driver with a drive strength of less than 0.5mA.

The calibration sequence is initiated on the rising edge of RESETN, as shown in [Figure 25](#). The Over-Range (OR) output is set high when RESETN is pulled low, and remains in that state until calibration is complete. The OR output returns to normal operation at that time, so it is important that the analog input is within the converter's full-scale range to observe the transition. If the input is in an over-range condition, the OR pin stays high, and it is not possible to detect the end of the calibration cycle.

While RESETN is low, the output clock (CLKOUTP/CLKOUTN) is set low. Normal operation of the output clock resumes at the next input clock edge (CLKP/CLKN) after RESETN is deasserted. At 250MSPS the nominal calibration time is 200ms, while the maximum calibration time is 550ms.

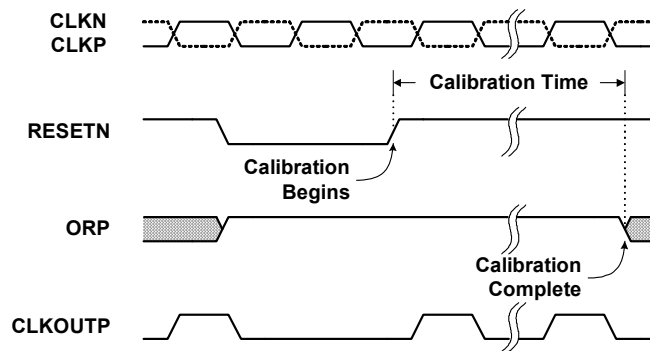

Figure 25. Calibration Timing

4.3 User-Initiated Reset

Recalibration of the ADC can be initiated at any time by driving the RESETN pin low for a minimum of one clock cycle. An open-drain driver with a drive strength of less than 0.5mA is recommended because RESETN has an internal high impedance pull-up to OVDD. As is the case during power-on reset, the SDO, RESETN, and DNC pins must be in the proper state for the calibration to successfully execute.

The performance of the KAD5514P changes with variations in temperature, supply voltage, and sample rate. The extent of these changes may necessitate recalibration, depending on system performance requirements. Best performance is achieved by recalibrating the ADC under the environmental conditions at which it operates.

A supply voltage variation of less than 100mV generally results in an SNR change of less than 0.5dBFS and SFDR change of less than 3dBc. In situations where the sample rate is not constant, best results are obtained if the device is calibrated at the highest sample rate. Reducing the sample rate by less than 80MSPS typically results in an SNR change of less than 0.5dBFS and an SFDR change of less than 3dBc.

[Figures 26](#) and [27](#) on [page 21](#) show the effect of temperature on SNR and SFDR performance with calibration performed at -40°C, +25°C, and +85°C. Each plot shows the variation of SNR/SFDR across temperature after a single calibration at -40°C, +25°C, and +85°C. Best performance is typically achieved by a user-initiated calibration at the operating conditions, as stated earlier. However, performance drift with temperature is not a very strong function of the temperature at which the calibration is performed. Full-rated performance is achieved after power-up calibration regardless of the operating conditions.

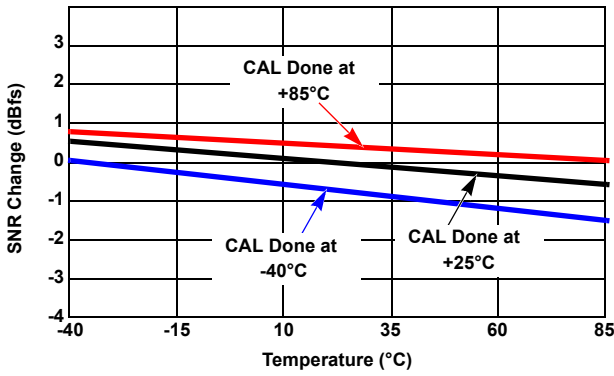

Figure 26. SNR Performance vs Temperature

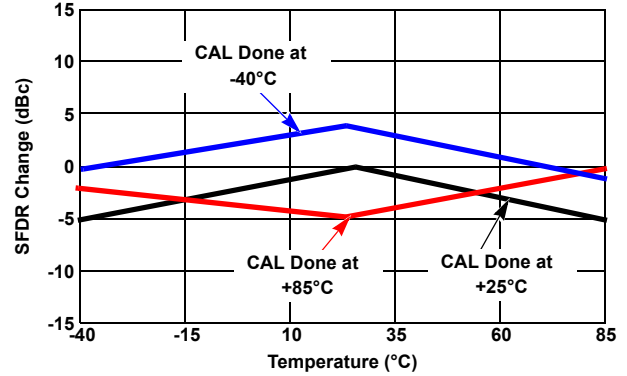

Figure 27. SFDR Performance vs Temperature

4.4 Analog Input

A single fully differential input (VINP/VINN) connects to the Sample and Hold Amplifier (SHA) of each unit ADC. The ideal full-scale input voltage is 1.45V, centered at the VCM voltage of 0.535V as shown in [Figure 28](#).

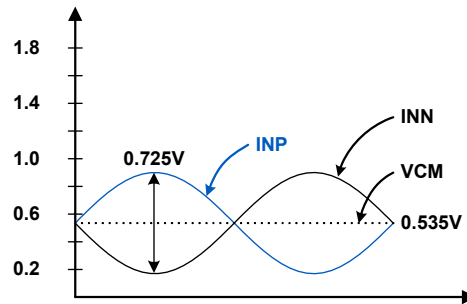

Figure 28. Analog Input Range

Best performance is obtained when the analog inputs are driven differentially. The common-mode output voltage, VCM, should be used to properly bias the inputs as shown in [Figures 29](#) through [31](#). An RF transformer gives the best noise and distortion performance for wideband and/or high Intermediate Frequency (IF) inputs. Two different transformer input schemes are shown in [Figures 29](#) and [30](#).

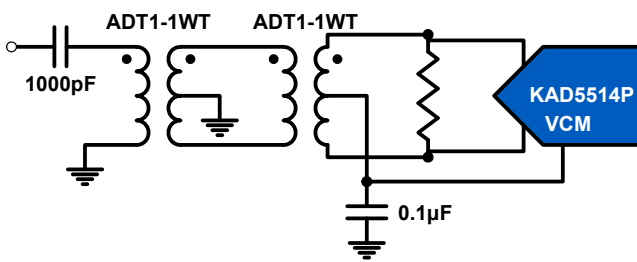

Figure 29. Transformer Input for General Purpose Applications

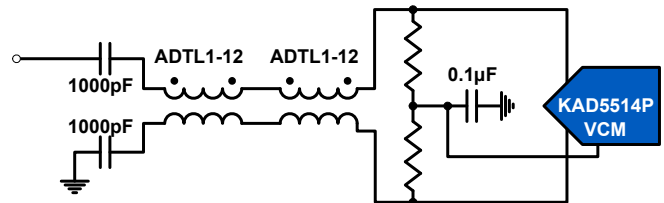

Figure 30. Transmission-Line Transformer Input for High IF Applications

This dual transformer scheme improves common-mode rejection, which keeps the common-mode level of the input matched to VCM. The value of the shunt resistor should be determined based on the load impedance. The differential input resistance of the KAD5514P is 500Ω.

The SHA design uses a switched capacitor input stage (see [Figure 44 on page 36](#)), which creates current spikes when the sampling capacitance is reconnected to the input voltage.

The current spikes a disturbance at the input which must settle before the next sampling point. Lower source impedance results in faster settling and improved performance. Therefore a 1:1 transformer and low shunt resistance are recommended for optimal performance.

A differential amplifier, as shown in [Figure 31](#), can be used in applications that require DC coupling. In this configuration, the amplifier typically dominates the achievable SNR and distortion performance.

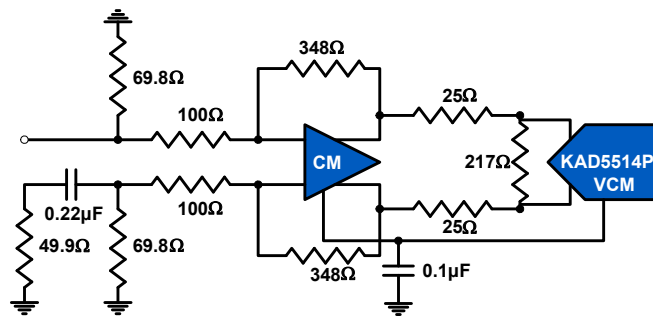

Figure 31. Differential Amplifier Input

4.5 Clock Input

The clock input circuit is a differential pair (see [Figure 45 on page 36](#)). Driving these inputs with a high level (up to 1.8V_{P-P} on each input) sine or square wave provides the lowest jitter performance. A transformer with 4:1 impedance ratio provides increased drive levels.

The recommended drive circuit is shown in [Figure 32](#). A duty range of 40% to 60% is acceptable. The clock can be driven single-ended, but this reduces the edge rate and may impact SNR performance. The clock inputs are internally self-biased to AVDD/2 to facilitate AC coupling.

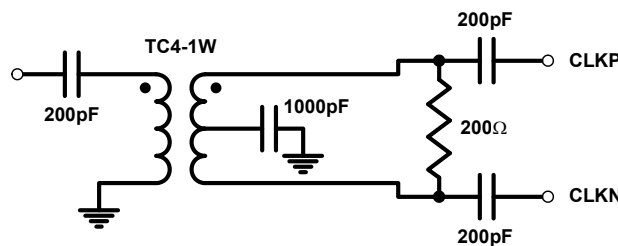

Figure 32. Recommended Clock Drive

A selectable 2x frequency divider is provided in series with the clock input. The divider can be used in the 2x mode with a sample clock equal to twice the desired sample rate. This allows the use of the Phase Slip feature, which enables synchronization of multiple ADCs.

Table 2. CLKDIV Pin Settings

CLKDIV Pin	DIVIDE Ratio
AVSS	2
Float	1
AVDD	4

The clock divider can also be controlled through the SPI port, which overrides the CLKDIV pin setting. Details on this are contained in [“Serial Peripheral Interface” on page 27](#).

A Delay-Locked Loop (DLL) generates internal clock signals for various stages within the charge pipeline. If the frequency of the input clock changes, the DLL may take up to 52μs to regain lock at 250MSPS. The lock time is inversely proportional to the sample rate.

The DLL has two ranges of operation, slow and fast. The slow range can be used for sample rates between 40MSPS and 100MSPS, while the default fast range can be used from 80MSPS to the maximum specified sample rate.

4.6 Jitter

In a sampled data system, clock jitter directly impacts the achievable SNR performance. The theoretical relationship between clock jitter (t_j) and SNR is shown in [Equation 1](#) and is illustrated in [Figure 33](#).

$$(EQ. 1) \quad SNR = 20 \log_{10} \left(\frac{1}{2\pi f_{IN} t_j} \right)$$

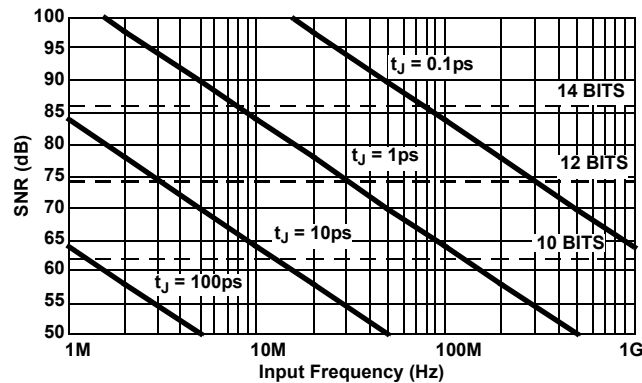

Figure 33. SNR vs Clock Jitter

This relationship shows the SNR that would be achieved if clock jitter were the only non-ideal factor. In reality, achievable SNR is limited by internal factors such as linearity, aperture jitter, and thermal noise. Internal aperture jitter is the uncertainty in the sampling instant shown in [“LVDS Timing Diagrams” on page 14](#). The internal aperture jitter combines with the input clock jitter in a root-sum-square fashion, because they are not statistically correlated, and this determines the total jitter in the system. The total jitter, combined with other noise sources, then determines the achievable SNR.

4.7 Voltage Reference

A temperature compensated voltage reference provides the reference charges used in the successive approximation operations. The full-scale range of each ADC is proportional to the reference voltage. The voltage reference is internally bypassed and is not accessible to you.

4.8 Digital Outputs

Output data is available as a parallel bus in LVDS-compatible or CMOS modes. Additionally, the data can be presented in either Double Data Rate (DDR) or Single Data Rate (SDR) formats. The even numbered data output pins are active in DDR mode in the 72 Ld package option. When CLKOUT is low the MSB and all odd logical bits are output, while on the high phase the LSB and all even logical bits are presented (this is true in both the 72 Ld and 48 Ld package options). The [“Timing Diagrams” on page 14](#) show the timing relationships for LVDS/CMOS and DDR/SDR modes.

The 48 Ld QFN package option contains seven LVDS data output pin pairs, and therefore can only support DDR mode.

Additionally, the drive current for LVDS mode can be set to a nominal 3mA or a power-saving 2mA. The lower current setting can be used in designs where the receiver is in close physical proximity to the ADC. The applicability of this setting is dependent upon the PCB layout, therefore you should experiment to determine if performance degradation is observed.

The output mode and LVDS drive current are selected using the OUTMODE pin as shown in [Table 3 on page 24](#).

Table 3. OUTMODE Pin Settings

OUTMODE Pin	Mode
AVSS	LVC MOS
Float	LVDS, 3mA
AVDD	LVDS, 2mA

The output mode can also be controlled through the SPI port, which overrides the OUTMODE pin setting. Details on this are contained in the [“Serial Peripheral Interface” on page 27](#).

An external resistor creates the bias for the LVDS drivers. A 10kΩ, 1% resistor must be connected from the RLVD pin to OVSS.

4.9 Over-Range Indicator

The Over-Range (OR) bit is asserted when the output code reaches positive full-scale (such as 0xFFF in offset binary mode). The output code does not wrap around during an over-range condition. The OR bit is updated at the sample rate.

4.10 Power Dissipation

The power dissipated by the KAD5514P is primarily dependent on the sample rate and the output modes: LVDS vs CMOS and DDR vs SDR. There is a static bias in the analog supply, while the remaining power dissipation is linearly related to the sample rate. The output supply dissipation changes to a lesser degree in LVDS mode, but is more strongly related to the clock frequency in CMOS mode.

4.11 Nap/Sleep

Portions of the device can be shut down to save power during times when operation of the ADC is not required. Two power saving modes are available: Nap, and Sleep. Nap mode reduces power dissipation to less than 170.2mW and recovers to normal operation in approximately 1μs. Sleep mode reduces power dissipation to less than 6mW but requires approximately 1ms to recover from a sleep command.

Wake-up time from sleep mode is dependent on the state of CSB; in a typical application CSB would be held high during sleep, requiring you to wait 150μs maximum after CSB is asserted (brought low) prior to writing '001x' to SPI Register 25. The device would be fully powered up, in normal mode 1ms after this command is written.

Wake-up from Sleep Mode Sequence (CSB high):

1. Pull CSB Low
2. Wait 150us
3. Write '001x' to Register 25
4. Wait 1ms until ADC fully powered on

In an application where CSB was kept low in Sleep mode, the 150μs CSB set-up time is not required as the SPI registers are powered on when CSB is low, the chip power dissipation increases by ~ 15mW in this case. The 1ms wake-up time after the write of a '001x' to register 25 still applies. It is generally recommended to keep CSB high in Sleep mode to avoid any unintentional SPI activity on the ADC.

All digital outputs (Data, CLKOUT and OR) are placed in a high impedance state during Nap or Sleep. The input clock should remain running and at a fixed frequency during Nap or Sleep, and CSB should be high. Recovery time from Nap mode increases if the clock is stopped, because the internal DLL can take up to 52μs to regain lock at 250MSPS.

By default after the device is powered on, the operational state is controlled by the NAPSLP pin as shown in [Table 4 on page 25](#).

Table 4. NAPSLP Pin Settings

NAPSLP Pin	Mode
AVSS	Normal
Float	Sleep
AVDD	Nap

The power-down mode can also be controlled through the SPI port, which overrides the NAPSLP pin setting. Details on this are contained in the [“Serial Peripheral Interface” on page 27](#). This is an indexed function when controlled from the SPI, but a global function when driven from the pin.

4.12 Data Format

Output data can be presented in three formats:

- Two’s complement
- Gray code
- Offset binary

The data format is selected using the OUTFMT pin as shown in [Table 5](#).

Table 5. OUTFMT Pin Settings

OUTFMT Pin	Mode
AVSS	Offset Binary
Float	Two’s Complement
AVDD	Gray Code

The data format can also be controlled through the SPI port, which overrides the OUTFMT pin setting. Details on this are contained in the [“Serial Peripheral Interface” on page 27](#).

Offset binary coding maps the most negative input voltage to code 0x000 (all zeros) and the most positive input to 0xFF (all ones). Two’s complement coding simply complements the MSB of the offset binary representation.

When calculating Gray code the MSB is unchanged. The remaining bits are computed as the XOR of the current bit position and the next most significant bit. [Figure 34](#) shows this operation.

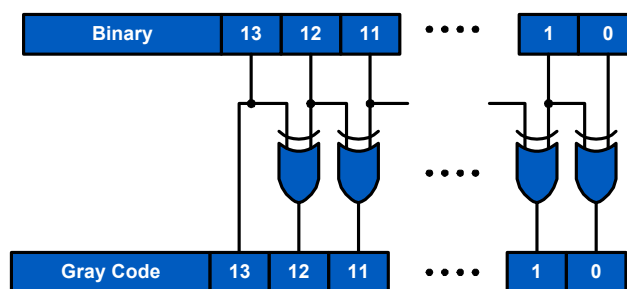
**Figure 34. Binary to Gray Code Conversion**

Converting back to offset binary from Gray code must be done recursively, using the result of each bit for the next lower bit as shown in [Figure 35 on page 26](#).

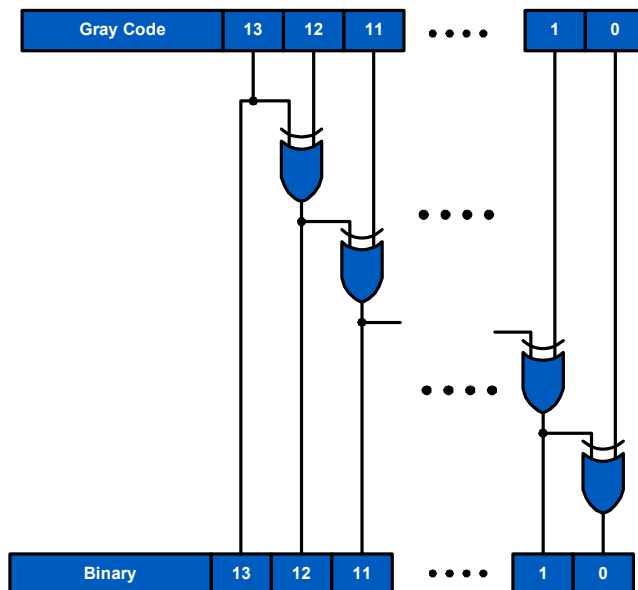

Figure 35. Gray Code to Binary Conversion

Mapping of the input voltage to the various data formats is shown in [Table 6](#).

Table 6. Input Voltage to Output Code Mapping

Input Voltage	Offset Binary	Two's Complement	Gray Code
-Full-Scale	000 00 000 00 00 00	100 00 000 00 00 00	000 00 000 00 00 00
-Full -Scale + 1 LSB	000 00 000 00 00 01	100 00 000 00 00 01	000 00 000 00 00 01
Mid-Scale	100 00 000 00 00 00	000 00 000 00 00 00	110 00 000 00 00 00
+Full-Scale - 1 LSB	111 11 111 11 11 10	011 11 111 11 11 10	100 00 000 00 00 01
+Full-Scale	111 11 111 11 11 11	011 11 111 11 11 11	100 00 000 00 00 00

5. Serial Peripheral Interface

A Serial Peripheral Interface (SPI) bus facilitates configuration of the device and to optimize performance. The SPI bus consists of Chip Select Bar (CSB), Serial Clock (SCLK) Serial Data Input (SDI), and Serial Data Input/Output (SDIO). The maximum SCLK rate is equal to the ADC sample rate (f_{SAMPLE}) divided by 16 for write operations and f_{SAMPLE} divided by 66 for reads. At $f_{SAMPLE} = 250\text{MHz}$, maximum SCLK is 15.63MHz for writing and 3.79MHz for read operations. There is no minimum SCLK rate.

The following sections describe various registers that configure the SPI or adjust performance or functional parameters. Many registers in the available address space (0x00 to 0xFF) are not defined in this document. Additionally, within a defined register there may be certain bits or bit combinations that are reserved. Undefined registers and undefined values within defined registers are reserved and should not be selected. Setting any reserved register or value may produce indeterminate results.

5.1 SPI Physical Interface

The Serial Clock pin (SCLK) provides synchronization for the data transfer. By default, all data is presented on the Serial Data Input/Output (SDIO) pin in 3-wire mode. The state of the SDIO pin is set automatically in the communication protocol (described in the following). A dedicated Serial Data Output pin (SDO) can be activated by setting 0x00[7] high to allow operation in 4-wire mode.

The SPI port operates in a half duplex master/slave configuration, with the KAD5514P functioning as a slave. Multiple slave devices can interface to a single master in 3-wire mode only, because the SDO output of an unaddressed device is asserted in 4-wire mode.

The Chip-Select Bar (CSB) pin determines when a slave device is being addressed. Multiple slave devices can be written to concurrently, but only one slave device can be read from at a given time (again, only in 3-wire mode). If multiple slave devices are selected for reading at the same time, the results are indeterminate.

The communication protocol begins with an instruction/address phase. The first rising SCLK edge following a HIGH to LOW transition on CSB determines the beginning of the two-byte instruction/address command. SCLK must be static low before the CSB transition. Data can be presented in MSB-first order or LSB-first order. The default is MSB-first, but this can be changed by setting 0x00[6] high. [Figures 36](#) and [37](#) show the appropriate bit ordering for the MSB-first and LSB-first modes, respectively. In MSB-first mode the address is incremented for multi-byte transfers, while in LSB-first mode it is decremented.

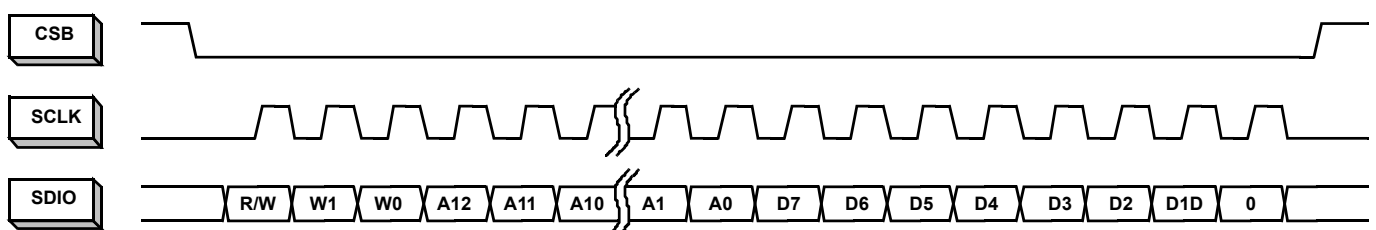

Figure 36. MSB-First Addressing

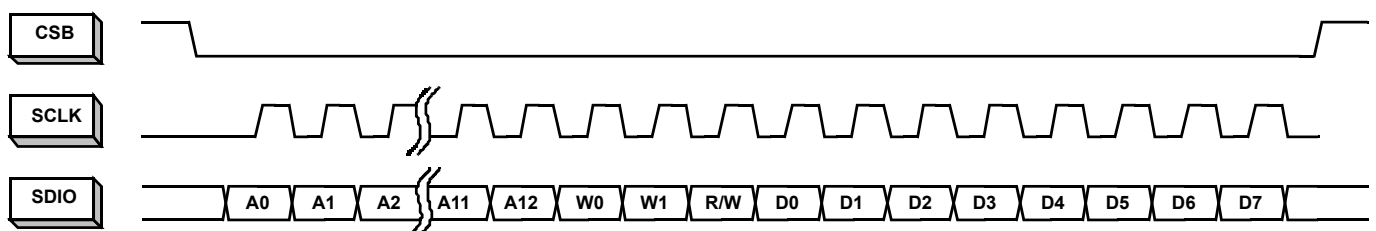

Figure 37. LSB-First Addressing

In the default mode the MSB is R/W, which determines if the data is to be read (active high) or written (active low). The next two bits, W1 and W0, determine the number of data bytes to be read or written (see [Table 7](#)). The lower 13 bits contain the first address for the data transfer. This relationship is illustrated in [Figure 38](#), and timing values are given in the [“Switching Specifications” on page 14](#).

After the instruction/address bytes have been read, the appropriate number of data bytes are written to or read from the ADC (based on the R/W bit status). The data transfer continues as long as CSB remains low and SCLK is active. Stalling of the CSB pin is allowed at any byte boundary (instruction/address or data) if the number of bytes being transferred is three or less. For transfers of four bytes or more, CSB is allowed stall in the middle of the instruction/address bytes or before the first data byte. If CSB transitions to a high state after that point the state machine resets and terminates the data transfer.

Table 7. Byte Transfer Selection

[W1:W0]	Bytes Transferred
00	1
01	2
10	3
11	4 or more

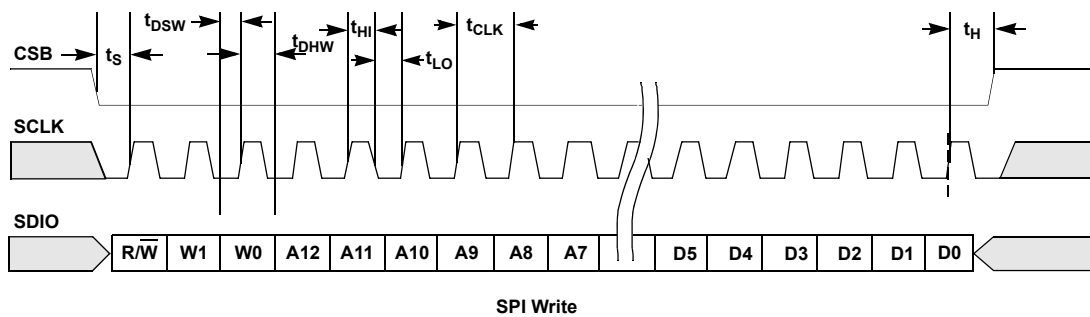

Figure 38. Write Timing

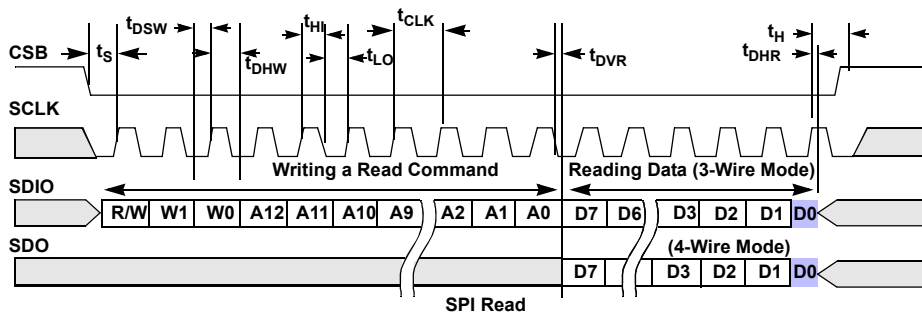

Figure 39. Read Timing

[Figures 40](#) and [41](#) illustrate the timing relationships for 2-byte and N-byte transfers, respectively. The operation for a 3-byte transfer can be inferred from these diagrams.

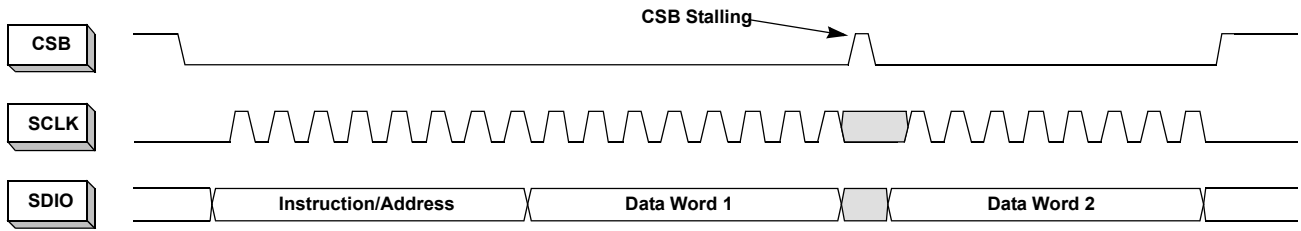

Figure 40. 2-Byte Transfer

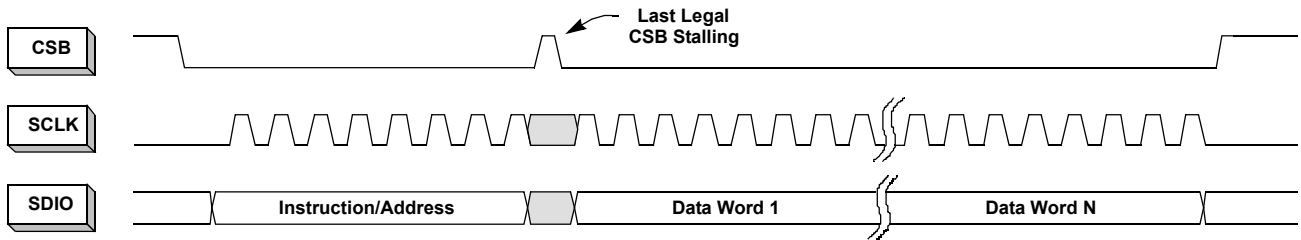

Figure 41. N-Byte Transfer

5.2 SPI Configuration

5.2.1 Address 0x00: CHIP_PORT_CONFIG

Bit ordering and SPI reset are controlled by this register. Bit order can be selected as MSB to LSB (MSB first) or LSB to MSB (LSB first) to accommodate various microcontrollers.

Bit Number	Bit Name	Description
7	SDO Active	
6	LSB First	Setting this bit high configures the SPI to interpret serial data as arriving in LSB to MSB order.
5	Soft Reset	Setting this bit high resets all SPI registers to default values.
4	Reserved	This bit should always be set high.
3:0		These bits should always mirror bits 4:7 to avoid ambiguity in bit ordering.

5.2.2 Address 0x02: BURST_END

If a series of sequential registers are to be set, burst mode can improve throughput by eliminating redundant addressing. In 3-wire SPI mode the burst is ended by pulling the CSB pin high. If the device is operated in two-wire mode the CSB pin is not available. In that case, setting the burst_end address determines the end of the transfer. During a write operation, you must be cautious to transmit the correct number of bytes based on the starting and ending addresses.

Bit Number	Bit Name	Description
7:0	Burst End Address	This register value determines the ending address of the burst data.

5.3 Device Information

5.3.1 Address 0x08: CHIP_ID

5.3.2 Address 0x09: CHIP_VERSION

The generic die identifier and a revision number, respectively, can be read from these two registers.

5.4 Indexed Device Configuration/Control

5.4.1 Address 0x10: DEVICE_INDEX_A

A common SPI map, which can accommodate single-channel or multi-channel devices, is used for all the ADC products. Certain configuration commands (identified as Indexed in the SPI map) can be executed on a per-converter basis. This register determines which converter is being addressed for an Indexed command. It is important to note that only a single converter can be addressed at a time.

This register defaults to 00h, indicating that no ADC is addressed. Error code 'AD' is returned if any indexed register is read from without properly setting device_index_A.

5.4.2 Address 0x20: OFFSET_COARSE

5.4.3 Address 0x21: OFFSET_FINE

The input offset of each ADC core can be adjusted in fine and coarse steps. Both adjustments are made using an 8-bit word as detailed in [Table 8](#).

The default value of each register is the result of the self-calibration after initial power-up. If a register is to be incremented or decremented, you should first read the register value then write the incremented or decremented value back to the same register.

Table 8. Offset Adjustments

Parameter	0x20[7:0]	0x21[7:0]
	Coarse Offset	Fine Offset
Steps	255	255
-Full-Scale (0x00)	-133 LSB (-47mV)	-5 LSB (-1.75mV)
Mid-Scale (0x80)	0.0 LSB (0.0mV)	0.0 LSB
+Full-Scale (0xFF)	+133 LSB (+47mV)	+5 LSB (+1.75mV)
Nominal Step Size	1.04 LSB (0.37mV)	0.04 LSB (0.014mV)

5.4.4 Address 0x22: GAIN_COARSE

5.4.5 Address 0x23: GAIN_MEDIUM

5.4.6 Address 0x24: GAIN_FINE

Gain of each ADC core can be adjusted in coarse, medium and fine steps. Coarse gain is a 4-bit adjustment while medium and fine are 8-bit. Multiple Coarse Gain Bits can be set for a total adjustment range of $\pm 4.2\%$ ('0011' = $\sim -4.2\%$ and '1100' = $\sim +4.2\%$). Renesas recommends using one of the coarse gain settings (-4.2% , -2.8% , -1.4% , 0, 1.4% , 2.8% , 4.2%) and fine-tuning the gain using the registers at 23h and 24h.

The default value of each register is the result of the self-calibration after initial power-up. If a register is incremented or decremented, you should first read the register value then write the incremented or decremented value back to the same register.

Table 9. Coarse Gain Adjustment

0x22[3:0]	Nominal Coarse Gain Adjust (%)
Bit 3	+2.8
Bit 2	+1.4
Bit 1	-2.8
Bit 0	-1.4

Table 10. Medium and Fine Gain Adjustments

Parameter	0x23[7:0]	0x24[7:0]
	Medium Gain	Fine Gain
Steps	256	256
-Full-Scale (0x00)	-2%	-0.20%
Mid-Scale (0x80)	0.00%	0.00%
+Full -Scale (0xFF)	+2%	+0.2%
Nominal Step Size	0.016%	0.0016%

5.4.7 Address 0x25: Modes

Two distinct reduced power modes can be selected. By default, the tri-level NAPSLP pin can select normal operation, nap or sleep modes (see “[Nap/Sleep](#)” on page 24). This functionality can be overridden and controlled through the SPI. This is an indexed function when controlled from the SPI, but a global function when driven from the pin. This register is not changed by a soft reset.

Table 11. Power-Down Control

Value	0x25[2:0]
	Power-Down Mode
000	Pin Control
001	Normal Operation
010	Nap Mode
100	Sleep Mode

5.5 Global Device Configuration/Control

5.5.1 Address 0x71: PHASE_SLIP

When using the clock divider, it is not possible to determine the synchronization of the incoming and divided clock phases. This is particularly important when multiple ADCs are used in a time-interleaved system. The phase slip feature allows the rising edge of the divided clock to be advanced by one input clock cycle when in CLK/4 mode, as shown in [Figure 42](#). Execute a PHASE_SLIP command by first writing a ‘0’ to Bit 0 at address 71h followed by writing a ‘1’ to Bit 0 at address 71h (32 SCLK cycles).

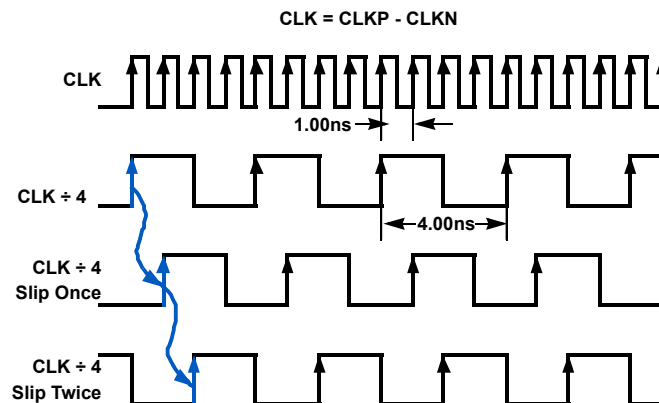

Figure 42. Phase Slip: CLK ÷4 Mode, f_{CLK} = 1000MHz

5.5.2 Address 0x72: CLOCK_DIVIDER

The KAD5514P has a selectable clock divider that can be set to divide by four, two, or one (no division). By default, the tri-level CLKDIV pin selects the divisor (see [“Clock Input” on page 22](#)). This functionality can be overridden and controlled through the SPI, as shown in [Table 12](#). This register is not changed by a soft reset.

Table 12. Clock Divider Selection

Value	0x72[2:0]
	Clock Divider
000	Pin Control
001	Divide by 1
010	Divide by 2
100	Divide by 4

5.5.3 Address 0x73: OUTPUT_MODE_A

The OUTPUT_MODE_A register controls the physical output format of the data and the logical coding. The KAD5514P can present output data in two physical formats: LVDS or LVCMOS. Additionally, the drive strength in LVDS mode can be set high (3mA) or low (2mA). By default, the tri-level OUTMODE pin selects the mode and drive level (see [“Digital Outputs” on page 23](#)). This functionality can be overridden and controlled through the SPI, as shown in [Table 13](#).

Table 13. Output Mode Control

Value	0x93[7:5]
	Output Mode
000	Pin Control
001	LVDS 2mA
010	LVDS 3mA
100	LVCMOS

Data can be coded in three possible formats: two’s complement, Gray code, or offset binary. By default, the tri-level OUTFMT pin selects the data format (see [“Data Format” on page 25](#)). This functionality can be overridden and controlled through the SPI, as shown in [Table 14](#).

This register is not changed by a soft reset.

Table 14. Output Format Control

Value	0x93[2:0]
	Output Format
000	Pin Control
001	Two’s Complement
010	Gray Code
100	Offset Binary

5.5.4 Address 0x74: OUTPUT_MODE_B

5.5.5 Address 0x75: CONFIG_STATUS

Bit Number	Bit Name	Description
6	DLL Range	Sets the DLL operating range to fast (default) or slow.
4	DDR Enable	Setting this bit enables Double Data Rate mode.

Internal clock signals are generated by a Delay-Locked Loop (DLL), which has a finite operating range. [Table 15](#) shows the allowable sample rate ranges for the slow and fast settings.

Table 15. DLL Ranges

DLL Range	Min	Max	Unit
Slow	40	100	MSPS
Fast	80	$f_{S \text{ MAX}}$	MSPS

The OUTPUT_MODE_B and CONFIG_STATUS registers are used in conjunction to enable DDR mode and select the frequency range of the DLL clock generator. The method of setting these options is different from the other registers.

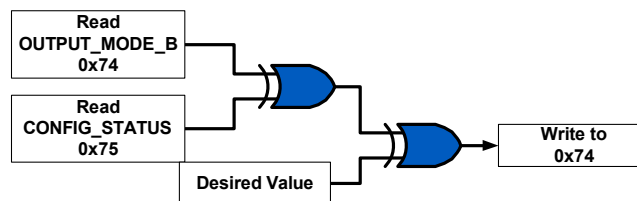

Figure 43. Setting OUTPUT_MODE_B Register

The procedure for setting OUTPUT_MODE_B is shown in [Figure 43](#). Read the contents of OUTPUT_MODE_B and CONFIG_STATUS and XOR them. Then XOR this result with the desired value for OUTPUT_MODE_B and write that XOR result to the register.

5.6 Device Test

The KAD5514P can produce preset or user defined patterns on the digital outputs to facilitate in-situ testing. A static word can be placed on the output bus, or two different words can alternate. In the alternate mode, the values defined as Word 1 and Word 2 (as shown in [Table 16](#)) are set on the output bus on alternating clock phases. The test mode is enabled asynchronously to the sample clock, therefore several sample clock cycles may elapse before the data is present on the output bus.

5.6.1 Address 0xC0: TEST_IO

Bit Number	Bit Name	Description
7:6	User Test Mode	These bits set the test mode to static (0x00) or alternate (0x01) mode. Other values are reserved.

The four LSBs in this register (Output Test Mode) determine the test pattern in combination with registers 0xC2 through 0xC5. See [Table 17 on page 34](#).

Table 16. Output Test Modes

Value	0xC0[3:0]	Word 1	Word 2
	Output Test Mode		
0000	Off		
0001	Midscale	0x8000	N/A
0010	Positive Full-Scale	0xFFFF	N/A
0011	Negative Full-Scale	0x0000	N/A
0100	Checkerboard	0xAAAA	0x5555
0101	Reserved	N/A	N/A
0110	Reserved	N/A	N/A
0111	One/Zero	0xFFFF	0x0000

Table 16. Output Test Modes (Continued)

Value	0xC0[3:0]	Word 1	Word 2
	Output Test Mode		
1000	User Pattern	user_patt1	user_patt2

5.6.2 Address 0xC2: USER_PATT1_LSB**5.6.3 Address 0xC3: USER_PATT1_MSB**

These registers define the lower and upper eight bits, respectively, of the first user-defined test word.

5.6.4 Address 0xC2: USER_PATT2_LSB**5.6.5 Address 0xC3: USER_PATT2_MSB**

These registers define the lower and upper eight bits, respectively, of the second user-defined test word.

5.7 SPI Memory Map**Table 17. SPI Memory Map**

	Addr (Hex)	Parameter Name	Bit 7 (MSB)	Bit 6	Bit 5	Bit 4	Bit 3	Bit 2	Bit 1	Bit 0 (LSB)	Def. Value (Hex)	Indexed /Global	
SPI Config	00	port_config	SDO Active	LSB First	Soft Reset			Mirror (Bit 5)	Mirror (Bit 6)	Mirror (Bit 7)	00h	G	
	01	reserved	Reserved										
	02	burst_end	Burst end address [7:0]									00h	G
	03-07	reserved	Reserved										
Info	08	chip_id	Chip ID #									Read only	G
	09	chip_version	Chip Version #									Read only	G
Indexed Device Config/Control	10	device_index_A	Reserved						ADC01	ADC00		00h	I
	11-1F	reserved	Reserved										
	20	offset_coarse	Coarse Offset									Cal. value	I
	21	offset_fine	Fine Offset									Cal. value	I
	22	gain_coarse	Reserved					Coarse Gain				Cal. value	I
	23	gain_medium	Medium Gain									Cal. value	I
	24	gain_fine	Fine Gain									Cal. value	I
	25	modes	Reserved						Power-Down Mode [2:0] 000 = Pin Control 001 = Normal Operation 010 = Nap 100 = Sleep Other Codes = Reserved			00h NOT affected by soft reset	I
26-5F	reserved	Reserved											
60-6F	reserved	Reserved											

Table 17. SPI Memory Map (Continued)

	Addr (Hex)	Parameter Name	Bit 7 (MSB)	Bit 6	Bit 5	Bit 4	Bit 3	Bit 2	Bit 1	Bit 0 (LSB)	Def. Value (Hex)	Indexed /Global	
Global Device Config/Control	70	reserved	Reserved										
	71	phase_slip	Reserved							Next Clock Edge		00h	G
	72	clock_divide						Clock Divide [2:0] 000 = Pin Control 001 = divide by 1 010 = divide by 2 100 = divide by 4 other codes = reserved				00h NOT affected by soft reset	G
	73	output_mode_A	Output Mode [2:0] 000 = Pin Control 001 = LVDS 2mA 010 = LVDS 3mA 100 = LVCMOS other codes = reserved					Output Format [2:0] 000 = Pin Control 001 = Twos Complement 010 = Gray Code 100 = Offset Binary Other Codes = Reserved				00h NOT affected by soft reset	G
	74	output_mode_B		DLL Range 0 = fast 1 = slow		DDR Enable (Note 14)						00h NOT affected by soft reset	G
	75	config_status		XOR Result		XOR Result						Read only	G
	76-BF	reserved	Reserved										
Device Test	C0	test_io	User Test Mode [1:0] 00 = Single 01 = Alternate 10 = Reserved 11 = Reserved					Output Test Mode [3:0] 0 = Off 1 = Midscale Short 2 = +FS Short 3 = -FS Short 4 = Checker Board 5 = Reserved 6 = Reserved			7 = One/Zero Word Toggle 8 = User Input 9-15 = Reserved	00h	G
	C1	Reserved	Reserved									00h	G
	C2	user_patt1_lsb	B7	B6	B5	B4	B3	B2	B1	B0	00h	G	
	C3	user_patt1_msb	B15	B14	B13	B12	B11	B10	B9	B8	00h	G	
	C4	user_patt2_lsb	B7	B6	B5	B4	B3	B2	B1	B0	00h	G	
	C5	user_patt2_msb	B15	B14	B13	B12	B11	B10	B9	B8	00h	G	
	C6-FF	reserved	Reserved										

Note:

14. At power-up, the DDR enable bit is at a logic '0' for the 72 Ld package and set to a logic '1' internally for the 48 Ld package by an internal pull-up.

6. Equivalent Circuits

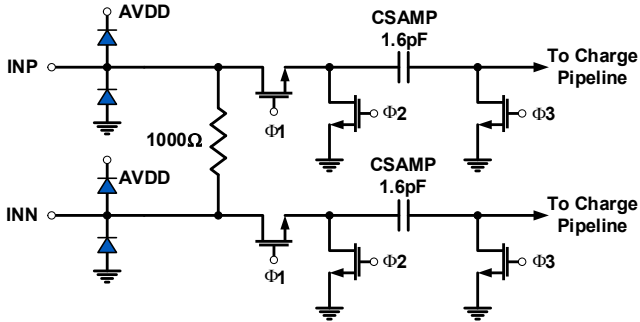

Figure 44. Analog Inputs

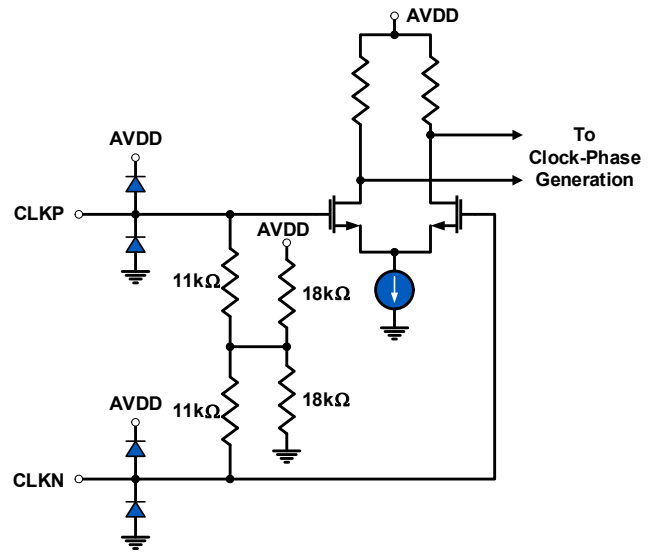

Figure 45. Clock Inputs

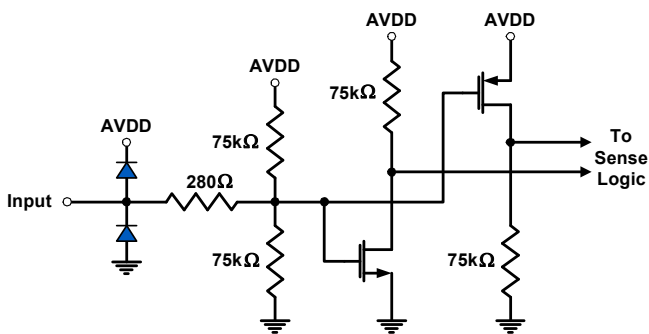

Figure 46. Tri-Level Digital Inputs

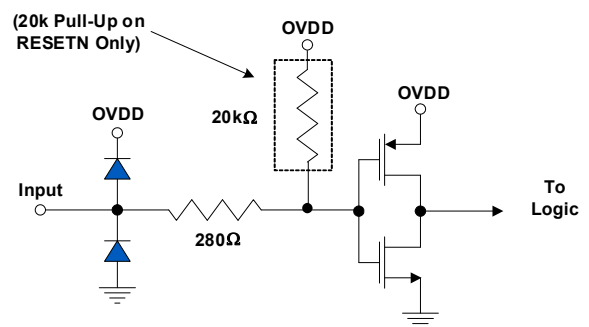

Figure 47. Digital Inputs

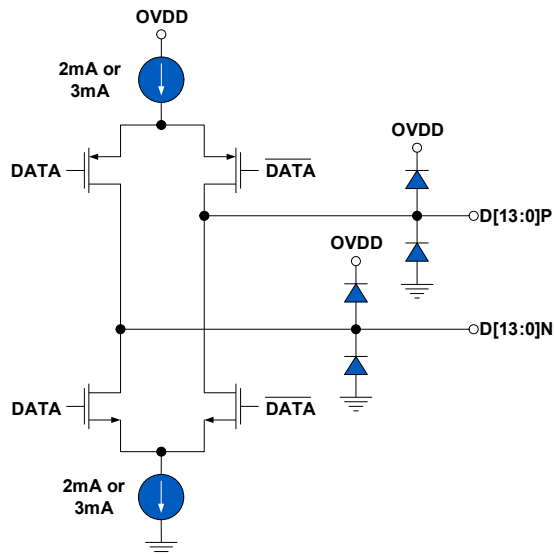

Figure 48. LVDS Outputs

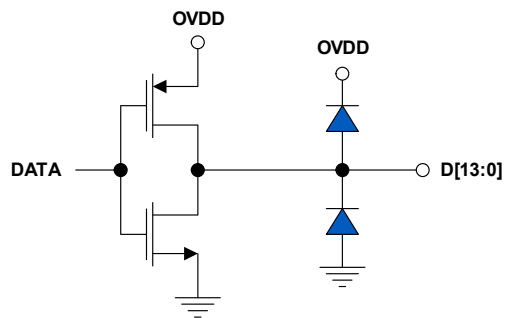

Figure 49. CMOS Outputs

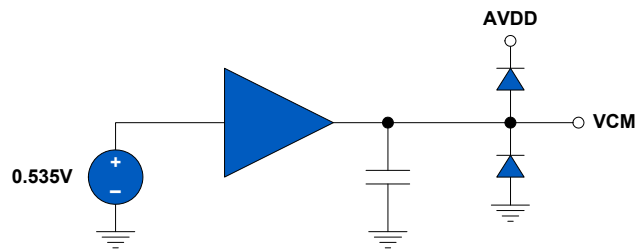

Figure 50. VCM_OUT Output

7. Layout Considerations

7.1 Split Ground and Power Planes

Data converters operating at high sampling frequencies require extra care in PC board layout. Many complex board designs benefit from isolating the analog and digital sections. Analog supply and ground planes should be laid out under signal and clock inputs. Place the digital planes under outputs and logic pins. Grounds should be joined under the chip.

7.2 Clock Input Considerations

Use matched transmission lines to the transformer inputs for the analog input and clock signals. Place transformers and terminations as close to the chip as possible.

7.3 Exposed Paddle

The exposed paddle must be electrically connected to analog ground (AVSS) and should be connected to a large copper plane using numerous vias for optimal thermal performance.

7.4 Bypass and Filtering

Bulk capacitors should have low equivalent series resistance. Tantalum is a good choice. For best performance, keep ceramic bypass capacitors very close to device pins. Longer traces increase inductance and decrease dynamic performance and accuracy. Make sure that connections to ground are direct and low impedance. Avoid forming ground loops.

7.5 LVDS Outputs

Output traces and connections must be designed for 50Ω (100Ω differential) characteristic impedance. Keep traces direct and minimize bends where possible. Avoid crossing ground and power-plane breaks with signal traces.

7.6 LVCMOS Outputs

Output traces and connections must be designed for 50Ω characteristic impedance.

7.7 Unused Inputs

Standard logic inputs (RESETN, CSB, SCLK, SDIO, SDO) that are not operated do not require connection to ensure optimal ADC performance. These inputs can be left floating if they are not used. Tri-level inputs (NAPSLP, OUTMODE, OUTFMT, CLKDIV) accept a floating input as a valid state and therefore should be biased according to their functionality.

7.8 72 Ld/48 Ld Package Options

The KAD5514 is available in both 72 Ld and 48 Ld packages. The 48 Ld package option supports LVDS DDR only. A reduced set of pin selectable functions are available in the 48 Ld package due to the reduced pinout; (OUTMODE, OUTFMT and CLKDIV pins are not available). [Table 18](#) shows the default state for these functions for the 48 Ld package. Note that these functions are available through the SPI, allowing you to set these modes and offer the same flexibility as the 72 Ld package option. DC and AC performance of the ADC is equivalent for both package options.

Table 18. 48 Ld SPI - Addressable Functions

Function	Description	Default State
CLKDIV	Clock Divider	Divide by 1
OUTMODE	Output Driver Mode	LVDS, 3mA (DDR)
OUTFMT	Data Coding	Two's Complement

8. ADC Evaluation Platform

Renesas offers an ADC Evaluation platform which can evaluate any of the KADxxxxx ADC family. The platform consists of a FPGA based data capture motherboard and a family of ADC daughtercards. This USB based platform allows you to quickly evaluate the ADC's performance at a user's specific application frequency requirements. More information is available on our [website](#).

9. Definitions

Analog Input Bandwidth is the analog input frequency at which the spectral output power at the fundamental frequency (as determined by FFT analysis) is reduced by 3dB from its full-scale low-frequency value. This is also referred to as Full Power Bandwidth.

Aperture Delay or Sampling Delay is the time required after the rise of the clock input for the sampling switch to open, at which time the signal is held for conversion.

Aperture Jitter is the RMS variation in aperture delay for a set of samples.

Clock Duty Cycle is the ratio of the time the clock wave is at logic high to the total time of one clock period.

Differential Nonlinearity (DNL) is the deviation of any code width from an ideal 1 LSB step.

Effective Number of Bits (ENOB) is an alternate method of specifying Signal to Noise and Distortion Ratio (SINAD). In dB, it is calculated as: $ENOB = (SINAD - 1.76)/6.02$.

Gain Error is the ratio of the difference between the voltages that cause the lowest and highest code transitions to the full-scale voltage less 2 LSB. It is typically expressed in percent.

Integral Nonlinearity (INL) is the maximum deviation of the ADC's transfer function from a best fit line determined by a least squares curve fit of that transfer function, measured in units of LSBs.

Least Significant Bit (LSB) is the bit that has the smallest value or weight in a digital word. Its value in terms of input voltage is $V_{FS}/(2^N - 1)$ where N is the resolution in bits.

Missing Codes are output codes that are skipped and never appear at the ADC output. These codes cannot be reached with any input value.

Most Significant Bit (MSB) is the bit that has the largest value or weight.

Pipeline Delay is the number of clock cycles between the initiation of a conversion and the appearance at the output pins of the data.

Power Supply Rejection Ratio (PSRR) is the ratio of the observed magnitude of a spur in the ADC FFT, caused by an AC signal superimposed on the power supply voltage.

Signal to Noise and Distortion (SINAD) is the ratio of the RMS signal amplitude to the RMS sum of all other spectral components below one half the clock frequency, including harmonics but excluding DC.

Signal-to-Noise Ratio (without Harmonics) is the ratio of the RMS signal amplitude to the RMS sum of all other spectral components below one-half the sampling frequency, excluding harmonics and DC.

SNR and SINAD are either given in units of dB when the power of the fundamental is used as the reference, or dBFS (dB to full-scale) when the converter's full-scale input power is used as the reference.

Spurious Free Dynamic Range (SFDR) is the ratio of the RMS signal amplitude to the RMS value of the largest spurious spectral component. The largest spurious spectral component may or may not be a harmonic.

10. Revision History

The revision history provided is for informational purposes only and is believed to be accurate, but not warranted. Please go to the web to make sure that you have the latest revision.

Date	Revision	Change
Jul.17.19	4.00	Applied new formatting throughout. Added Related Literature section. Updated links throughout. Changed Minimum "Signal to Noise Ratio", "SNR", "FIN 105MHZ" value from 66.9 to 66.4. Changed Minimum "Signal to Noise Distortion", "SINAD", "FIN 105MHZ" value from 66.4 to 65.9. Removed About Intersil section.
May.31.16	3.00	-Updated entire datasheet applying Intersil's new standards. -Updated the maximum "Electrical Specifications" for the following: -I _{AVDD} (KAD5514P-25): 180 to 190 (KAD5514P-21): 166 to 176 (KAD5514P-17): 153 to 163 (KAD5514P-14): 137 to 147. -NAP Mode (KAD5514P-25): 163 to 170.2 (KAD5514P-21): 157 to 164.2 (KAD5514P-17): 151 to 158.2 (KAD5512P-14): 143 to 150.2. -Updated 163 to 170.2 in "Nap/Sleep" on page 24. -Replaced Products section with About Intersil section.
Aug.24.09	2.00	1) Added nap mode, sleep mode wake up times to spec table 2) Added CSB,SCLK Setup time specs for nap, sleep modes 3) Added section showing 72 Ld/48 Ld package feature differences and default state for clkdiv,outmode,outfmt page 38 4) Changed SPI setup time specs wording in spec table 5) Added 'Reserved' to SPI memory map at address 25H 6) Renumbered Notes 7) Added test platform link on page 39 8) Added ddr enable note14 for 48 Ld/72 Ld options 9) Changed pin description table for 72/48 Ld option, added DDR notes 10) changed multi device note in spi physical interface section to show 3-wire application.page 27 11) Update digital output section for ddr operation page 23 12) change to fig26and fig27 and description in text 13) Added connect note for thermal pad 14) Formatted Figures 25 and 26 with Intersil Standards, 15) Change to SPI interface section in spec table, timing in cycles now, added write, read specific timing specs. 16) Updated SPI timing diagrams, Figures 37, 38 17) Updated wakeup time description in "Nap/Sleep" on page 24. 18) Removed calibration note in spec table 19) Changed label in fig 46 20) Updated cal paragraph in user initiated reset section per DC. -Changed tDHR spec needs from 1.5 to 3 cycles. -Moved 20k ohm label in fig 46 closer to resistor connected to ovdd
Feb.25.09	1.00	Corrected 48 QFN pin description table on page 11 to show OVDD pins from "20, 27" to "20, 37". Changed "odd" bits N in Figure 1A - DDR to "even" bits N, Replaced POD L48.7x7E due to changed dimension from "9.80 sq" to "6.80" sq. in land pattern.
Jan.15.09	0.00	P1; revised Key Specs P2; added Part Marking column to Order Info P4; moved Thermal Resistance to Thermal Info table and added Theta JA note 3 per packaging P4-8; revisions throughout spec tables. Added notes 9 and 10 to Switching Specs. P9; revised function for Pin 22 OUTMODE, Pin 23 NAPSLP and Pin 16 CLKDIV P11; revised function for Pin 16 NAPSLP P13-15; Added Typical Performance curves P17; added Figs 25-26 P17; User Initiated Reset - revised 2nd sentence of 1st paragraph P18; Serial Peripheral Interface- 1st paragraph; revised 4th sentence P19; revised Nap/Sleep; revised 3rd sentence of 1st paragraph P21; Serial Peripheral Interface- added 3rd sentence to 4th paragraph P23; Address 0x24: Gain_Fine; added 2 sentences to end of 1st paragraph. Revised Table 8 P24; removed Figure (PHASE SLIP: CLK+2 MODE, fCLOCK = 500MHz) Address 0x71: Phase_slip; added sentence to end of paragraph P27; Changed AVDD to OVDD in Fig 46 P27; revised Fig 45 P27; Table 16; revised Bits7:4, Addr C0 Throughout; formatted graphics to Intersil standards

11. Package Outline Drawings

For the most recent package outline drawing, see [L48.7x7E](#).

L48.7x7E
 48 LEAD QUAD FLAT NO-LEAD PLASTIC PACKAGE
 Rev 1, 2/09

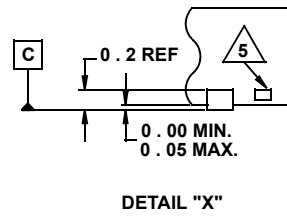
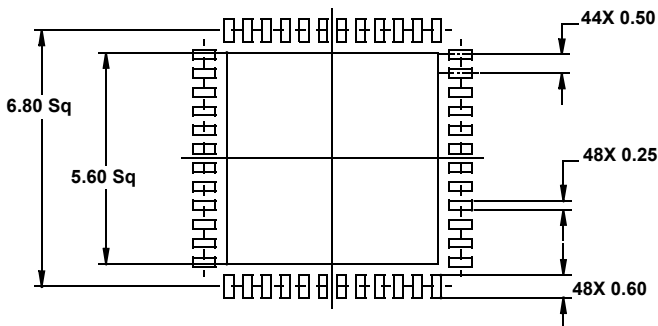
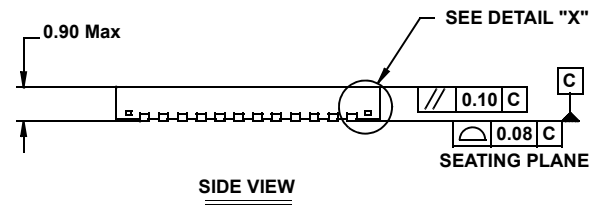
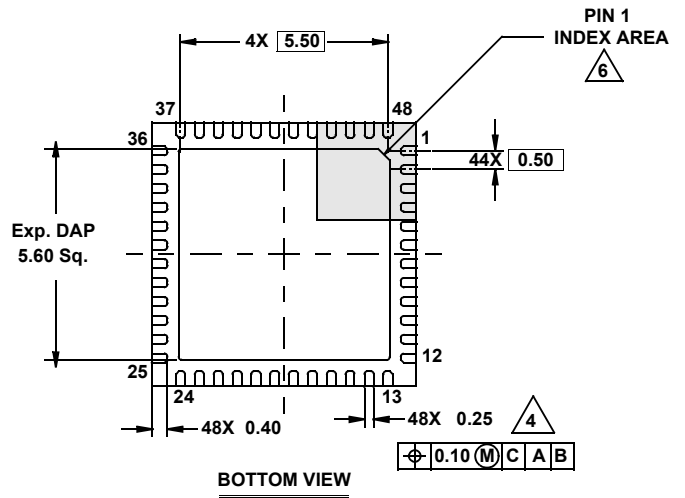
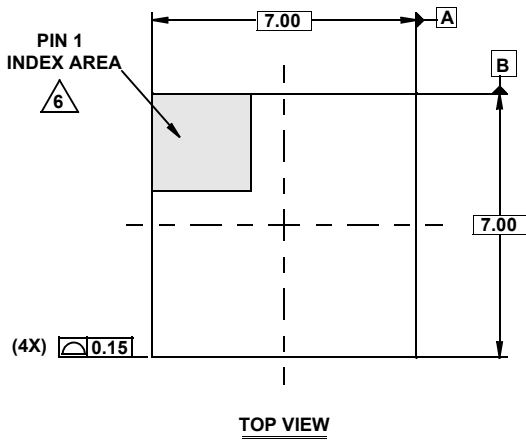

NOTES:

1. Dimensions are in millimeters.
Dimensions in () for Reference Only.
2. Dimensioning and tolerancing conform to AMSEY14.5m-1994.
3. Unless otherwise specified, tolerance: Decimal ± 0.05
4. Dimension b applies to the metallized terminal and is measured between 0.15mm and 0.30mm from the terminal tip.
5. Tiebar shown (if present) is a non-functional feature.
6. The configuration of the pin #1 identifier is optional, but must be located within the zone indicated. The pin #1 identifier may be either a mold or mark feature.

L72.10x10D
 72 LEAD QUAD FLAT NO-LEAD PLASTIC PACKAGE
 Rev 1, 11/08

For the most recent package outline drawing, see [L72.10x10D](#).

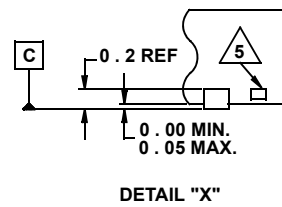
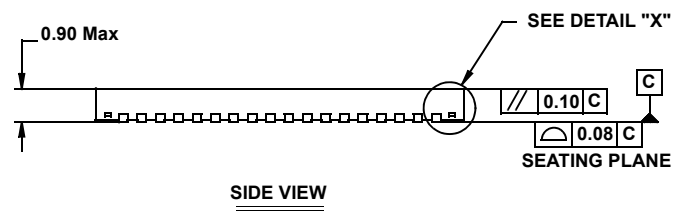
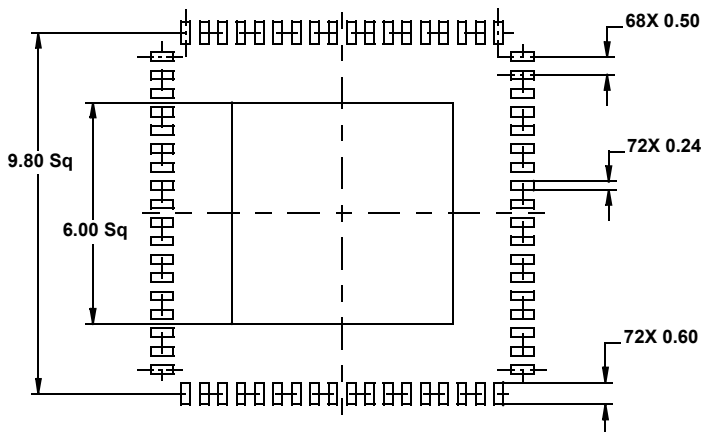
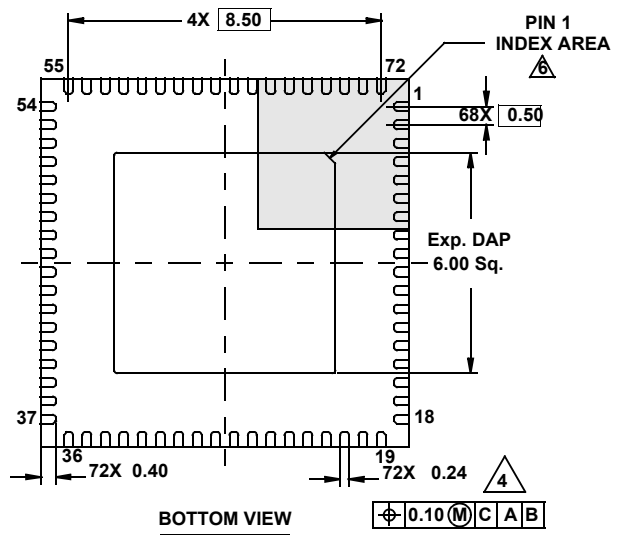
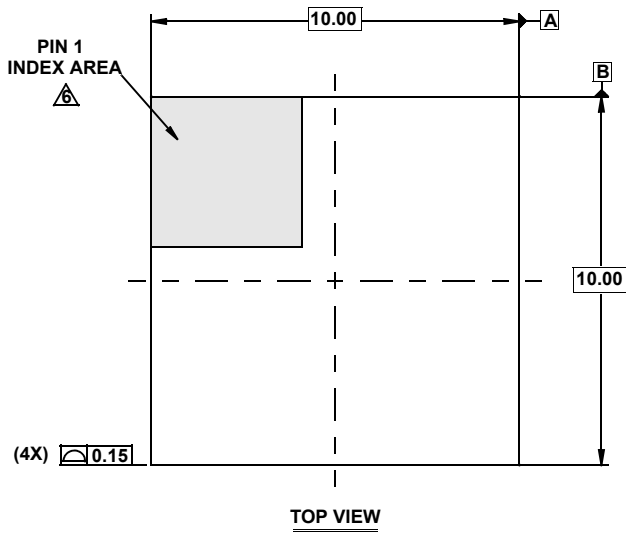

NOTES:

1. Dimensions are in millimeters.
Dimensions in () for Reference Only.
2. Dimensioning and tolerancing conform to AMSEY14.5m-1994.
3. Unless otherwise specified, tolerance: Decimal ± 0.05
4. Dimension b applies to the metallized terminal and is measured between 0.15mm and 0.30mm from the terminal tip.
5. Tiebar shown (if present) is a non-functional feature.
6. The configuration of the pin #1 identifier is optional, but must be located within the zone indicated. The pin #1 identifier may be either a mold or mark feature.